

## BUCKET SELECTION GUIDE

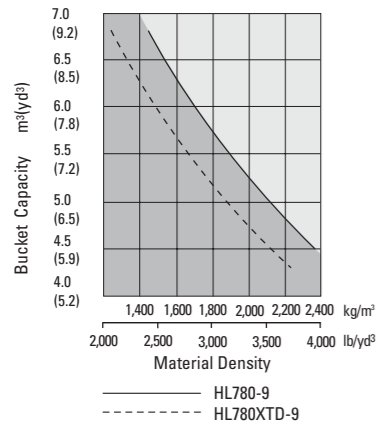

## SUPPLEMENTAL SPECIFICATIONS

| Description     | Change in operating weight kg(lb) | Change in static tipping load-straight kg(lb) | Change in static tipping load-40° turn kg(lb) |
|-----------------|-----------------------------------|---|---|
| 26.5-25 32PR L3 | -112 (-247)                       | -90 (-200)                                    | -80 (-175)                                    |
| 29.5-25 28PR L3 | +352 (+776)                       | +270 (+595)                                   | +240 (+530)                                   |
| 29.5-25 28PR L5 | +1,240 (+2,734)                   | +960 (+2,160)                                 | +850 (+1,870)                                 |
| 29.5 R25 XHA*   | +500 (+1,102)                     | +390 (+860)                                   | +340 (+750)                                   |

## STANDARD EQUIPMENT

|  |  |  |   |  |
|--|--|--|---|--|
| <p><b>Electrical system</b><br/>Alternator, 70A<br/>Alarms, audible and visual<br/>- air filter clogging<br/>- transmission error<br/>- alternator voltage<br/>- brake oil pressure<br/>- engine oil pressure<br/>- parking brake<br/>- fuel level<br/>- hydraulic oil temperature<br/>- coolant temperature<br/>- service brake oil pressure<br/>Alarm, back-up<br/>Batteries, 1,315 CCA, 12V, (2)<br/>Gauges<br/>- engine coolant temperature<br/>- fuel level<br/>- hydraulic oil temperature<br/>- speedometer<br/>- transmission oil temperature<br/>- voltmeter<br/>Horn, electric<br/>Indicator lights<br/>- clutch cut-off<br/>- high beam<br/>- turn signal<br/>- work light<br/>LCD Display<br/>- clock and fault code<br/>- operating hour counter<br/>- engine rpm</p> | <p>- transmission gear range indicator<br/>- job time and distance<br/>- temperature(coolant, hydraulic oil, t/m oil)<br/>Lighting system<br/>- 2 LED dome lights<br/>- 2 stop and tail lights<br/>- 4 turn signals<br/>- brake lights(counterweight)<br/>- 2 head lights on front tower<br/>- 2 working lights on front roof<br/>- 2 working lights on grill<br/>Switches<br/>- clutch cut-off<br/>- hazard<br/>- Ignition key, start/stop switch<br/>- main light(illumination and head light)<br/>- parking<br/>- rear wiper &amp; washer<br/>- work light<br/>- battery master switch<br/>- pilot cut-off<br/>Starter, electric<br/>Starting and charging system(24-volt)<br/><br/><b>Cab</b><br/>Cab, ROPS/FOPS<br/>(sound suppressed and pressurized) with :<br/>- cigar lighter &amp; ashtray</p> | <p>- coat hook<br/>Automatic climate control<br/>- air conditioner &amp; heater<br/>- defroster<br/>- intermittent wiper and washer, front and rear<br/>- personal storage space:<br/>Console box<br/>Holder, can and cup<br/>Rear view mirrors (2 inside)<br/>Rear view mirrors (2 outside)<br/>2" retractable seat belt &amp; adjustable suspension seat with armrests<br/>Steering column, tilt and telescopic<br/>Steering wheel with knob<br/>Sunvisor(front window)<br/>Tinted safety glass<br/>Two door cab<br/>Magazine pocket<br/>Pedals<br/>- one accelerator pedal<br/>- one brake pedal<br/>Radio/USB player<br/>Rubber floor mat<br/>Wrist rest<br/><br/><b>Engine</b><br/>Antifreeze<br/>Engine, Cummins QSM11<br/>- Low Emission Diesel, Tier3<br/>Engine enclosure, lockable</p> | <p>Engine fuel priming pump(Electric)<br/>3 operating mode<br/>(power / standard / econo)<br/>Fan guard<br/>Fuel/water separator<br/>Fuel warmer<br/>Muffler, under hood with large exhaust stack<br/>Rain cap, engine air intake<br/>Radiator<br/>Starting aid (air intake heater)<br/><br/><b>Power Train</b><br/>Brakes : Service, enclosed wet-disc<br/>Differentials, Hydraulic lock - front, limited slip - rear<br/>Parking brake<br/>Torque converter<br/>Transmission, computer-controlled, electronic soft shift, auto-shift and kick-shift features included<br/>Transmission oil cooler<br/><br/><b>Hydraulics</b><br/>Boom kickout, automatic<br/>Bucket positioner, automatic<br/>Diagnostic pressure taps<br/>Hydraulic oil cooler<br/>Hydraulic system,<br/>- 2 spool, single lever, pilot control for boom and bucket actuation<br/>Steering, load-sensing</p> | <p>Remote cooling fan, hydraulically-driven, temperature sensing type<br/><br/><b>Others</b><br/>Articulation locking bar<br/>Coolant level sight gauge<br/>Counterweight<br/>Door and cab locks, one key<br/>Doors, service access(locking)<br/>Drawbar with pin<br/>Engine oil level dipstick gauge<br/>Ergonomically located and slip resistant, left &amp; right<br/>- handrails<br/>- ladders<br/>- platforms<br/>- steps<br/>Fenders(front)<br/>Guard, bucket cylinder rod<br/>Hydraulic oil level sight gauge<br/>License plate bracket<br/>Lift and tie-down hooks<br/>Loader linkage, sealed<br/>Z-Bar design<br/>Steering stops, cushioned<br/>Tires(29.5-25, 22PR,L3)<br/>Transmission oil site level<br/>Vandalism protection blocks</p> |
|--|--|--|---|--|

## OPTIONAL EQUIPMENT

|   |   |  |  |  |
|---|---|--|--|--|
| <p>24-volt to 12-volt DC converter<br/>3 Spool<br/>Climate control<br/>- air conditioner only<br/>- heater only<br/>Beacon light, rotating<br/>Auxiliary, 2 working lights on front roof<br/>(Xenon working lights)<br/>Auxiliary, 2 working lights on rear roof<br/>Cutting edge, bolt-on type</p> | <p>Dual brake pedal<br/>Secondary steering system<br/>Fenders(rear-mudguard)<br/>Fire extinguisher<br/>High lift arrangement with additional counterweight,<br/>552kg(1,210lb)<br/>Hydraulic control, 2 lever<br/>Hydraulic control, 3 lever<br/>3rd spool for auxiliary function</p> | <p>Joystick with travel switch(FNR)<br/>Mud guard<br/>Operator suit<br/>Pallet forks<br/>Heated rear view mirrors<br/>(2 outside)<br/>Reversible cooling fan<br/>Ride control system<br/>Seat<br/>- 2" static seat belt &amp; adjustable</p> | <p>mechanical suspension (vinyl)<br/>- 3" static seat belt &amp; adjustable<br/>mechanical suspension<br/>- 2" retractable seat belt<br/>adjustable suspension (heated)<br/>Tires :<br/>- 29.5 - 25, 28PR L3<br/>- 29.5 - 25, 28PR L5<br/>- 26.5 - 25, 32PR L3<br/>- 29.5 R25 XHA*</p> | <p>Tool kit<br/>Tool tray, 2 pieces, bolt-on type<br/>Wheel chocks<br/>Pressure washer, engine air intake<br/>Joystick-steering<br/>Roll screen (rear window)<br/>License plate &amp; lamp<br/>Hi-Mate(Remote Management System)<br/>Rearview camera</p> |
|---|---|--|--|--|

Standard and optional equipment may vary. Contact your Hyundai dealer for more information. The machine may vary according to International standards. All imperial measurements rounded off to the nearest pound or inch.

PLEASE CONTACT

www.hyundai-ce.com

2010.03 Rev 0

**HYUNDAI**  
HEAVY INDUSTRIES CO.,LTD.  
**CONSTRUCTION EQUIPMENT**

Office (Sales Office)  
1 JEONHA-DONG, DONG-GU, ULSAN, KOREA TEL: (82) 52-202-7970, 7729, 0971 FAX: (82) 52-202-7979, 7720

U.S. Operation: Hyundai Construction Equipment Americas, Inc.  
955 ESTES AVENUE, ELK GROVE VILLAGE, IL. 60007, U.S.A. TEL: (1) 847-437-3333 FAX: (1) 847-437-3574

European Operation: Hyundai Heavy Industries Europe N.V.  
VOSSENDAAL 11, 2440 GEEL, BELGIUM TEL: (32) 14-56-2200 FAX: (32) 14-59-3405

India Operation: Hyundai Construction Equipment India Pvt., Ltd.  
PLOT NO.A-2, CHAKAN INDUSTRIAL AREA, VILL.- KHALUMBRE. TALUK.- KHED., DIST.- PUNE 410 501, INDIA  
TEL: (91) 21-3530-1700 FAX: (91) 21-3530-1712

We build a better future

# HL780-9

With Tier 3 Engine installed



\*Photo may include optional equipment.

**HYUNDAI**  
HEAVY INDUSTRIES CO.,LTD.



# Pride at Work

Hyundai Heavy Industries strives to build state-of-the-art earthmoving equipment to give every operator maximum performance, more precision, versatile machine preferences, and proven quality. Take pride in your work with Hyundai!



## HL780-9

### Machine Walk-Around

#### Reliable Main Components

##### Engine Technology

Proven, reliable, fuel efficient, low noise Cummins Tier-III QSM11 engine.  
Electronically controlled for optimum fuel to air ratio and clean, efficient combustion.  
Self-diagnostic system.  
3 engine modes, P (Power), S (Standard), E (Econo) for full power or reduced fuel consumption according to operator preference.

##### Full Automatic transmission

4 shift (Manual / Light / Normal / Heavy) shift mode by working condition  
Protective transmission at low temperature (Automatic warm-up system)  
Self-diagnostic & Memory of malfunction history  
Minimum travel shift shock by applying proportional controlling modulation valve / Self adjusting Clutch gap  
Kick-down button & FNR switch for operating comfort

##### Axle

Hydraulically lockable front differential and limited slip rear differential for easy driving on variable ground condition  
Self-adjusting & wheel speed brake

#### Improved Durability

Load sensing hydraulic system with variable displacement piston pump and closed-center MCV (main control valve).  
Long-life cooling system, designed for additional durability, resistant to thermal shock, impulse and vibration.  
Redesigned steering cylinder lug and bucket link, now cast steel for additional strength and reliability.

#### Enhanced Operator Comfort

##### Improved Visibility

Larger operator's cab for additional comfort.  
Redesigned cab with rounded front glass and larger door glass for a larger field of view.

##### Improved Convenience

Increased cooling & heating capacity with fully automatic climate control system.  
Tilting & telescopic steering column.  
Adjustable wrist rest for reduced operating stress.  
Multiple storage compartments.  
AM/FM Radio with MP3 interface and USB input.  
Improved ladder with 20 Degree incline and large, deep tread, aluminum cast steps for safer access and exit from the cab.

##### Advanced 5.7" Color Monitor

Easy-to-read new color LCD display.  
Auto boom kick out and bucket positioner - fully adjustable from within the cab.  
Integrated load weight system, viewable through the monitor, for improved work efficiency and overload prevention.  
Self diagnostic & monitoring system with active display of engine, hydraulic system, transmission and electrical component information.  
Color, rear-view, back-up camera for improved safety and convenience.  
RMS (Remote Management System) works through GPS/satellite technology to provide better customer service and support.

#### Serviceability

Reversible, swing-out, cooling fan for easy service and improved cooler maintenance.  
Ground level access to critical service points, filters and sight gauges for easy maintenance.  
Long life hydraulic filter and oil for reduced operating costs.



# Preference

Operating a 9 series wheel loader is unique to every operator. Operators can fully customize their work environment and operating preferences to fit their individual needs.



\*Photo may include optional equipment.



## Wide and Convenient Cab

The newly designed cab was conceived for more space, a wider field of view and operator comfort. The front windshield is rounded and 17% wider than the previous 7A series. Special attention was given to a clean, open and convenient interior with plenty of visibility on the machine surroundings and the job at hand. This well balanced combination of cab ergonomics puts the operator in the perfect position to work safely and securely. The 9 series cab's fully automatic climate control system features 11 air vents and increased cooling and heating capacity for optimum temperature control. The defroster vents located on the front and rear windows and a PTC (electric pre-heater) make working in cold weather more hospitable.

## Operator Comfort

In the 9 series cabin you can easily adjust the steering column and wrist rest to best suit your preferred comfort level. Pilot operated joystick controls are easy and comfortable to operate. An FNR (Forward/Neutral/Reverse) switch on the control lever facilitates easy selection of travel direction. Roller style sun screens on the front window and rear window allow the operator to reduce glare and improve visibility. Heated side mirrors feature built-in hot wires for quick defrosting during cold weather conditions.



Tilting / telescopic steering column

## Reduced Stress

Work is stressful enough. Your work environment should be stress free. Hyundai's 9 series cabin offers lots of amenities, additional space and a comfortable seat to minimize stress to the operator. A powerful climate control system provides the operator with optimum air temperature. An advanced audio system with AM/FM stereo with MP3 interface and USB input, plus remotely located controls is perfect for listening to music favorites.

## Advanced Color Monitor



The advanced new monitor with 5.7 inch wide color LCD screen allows the operator to easily and efficiently control the machine. The operator can adjust boom kick-out and bucket position via switches overhead while monitoring the adjustment settings through the monitor. An integrated load weight system that contributes to improved work efficiency, can also be viewed through the monitor. Self diagnostics, color rear-view camera maintenance check lists and start-up machine security, were integrated into the monitor to make the machine more versatile and the operator more productive. The new monitor display unit is mounted on an adjustable swivel mount to reduce glare and position according to operator preference.

## Monitor Tilt Range

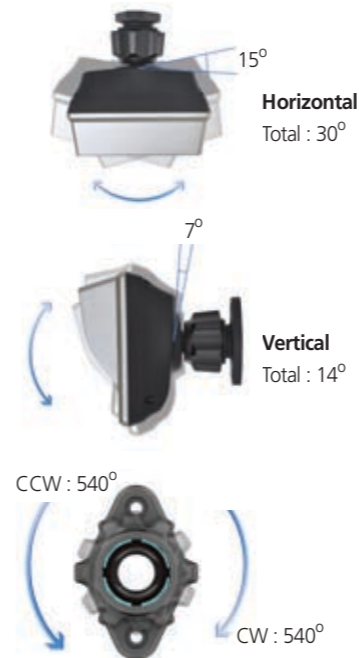



# Precision & Performance

Innovative hydraulic system technologies make the 9 series excavator fast, smooth and easy to control. 9 series is designed for maximum performance to keep the operator working productively.



## Improved Durability & Reliability



The new low-lossing hydraulic system with a variable volume piston pump and closed center main control valve, provide efficient hydraulic power and additional energy savings. Service and clean-out are easier on the 9 series, now equipped with a completely redesigned, front-mounted, cooler configuration and non louvered fins to prevent clogging. Air coolers are designed with aluminum bar plate configuration and undergo strict factory tests for thermal shock, impulse and vibration to assure long term durability. Top mounted non-louvered aluminum air condenser and variable displacement AVC compressor are designed for maximum cooling capacity, energy savings and easy clean-out. Additionally, the redesigned steering cylinder lug and bucket link, are now cast steel for additional strength and reliability.

## Variable Operating Modes



9 series wheel loaders are designed to allow the operator to customize the machine's engine power, automatic transmission shift timing and clutch cut-off activation based on the job condition and personal operator preference. Convenient rotary type switches allow for easy adjustment of engine power mode, transmission power shift mode, and clutch cut-off mode. Additionally, if equipped with the optional ride control system, the operator has the option to turn the system on or off with an overhead switch. The ride control system has a shock absorbing accumulator that cushions the boom, improves operator comfort and reduces material loss. The versatility of the 9 series operating modes contributes to improved productivity, enhanced operator comfort and reduced fuel consumption.



**3 Mode Engine Power Selection**  
 P(Power) Mode : Heavy duty work  
 S(Standard) Mode : General work  
 E(Economy) Mode : Light duty work

**4 Mode Transmission Power Shift System**  
 M(Manual) Mode  
 Auto L(Light) Mode : Light duty & long distance carry  
 Auto N(Normal) Mode : General excavating & loading  
 Auto H(Heavy) Mode : Heavy duty excavating & loading

**3 Mode Clutch Cut-Off System**  
 L(Low) Mode : Short distance & faster loading  
 M(Medium) Mode : General loading  
 H(High) Mode : Slope ground

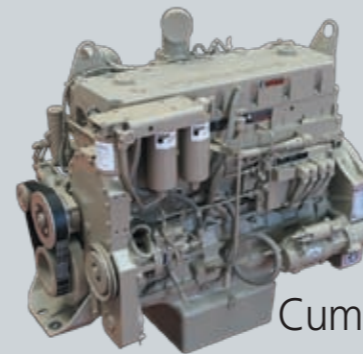

Eco-friendly  
Cummins QSM11 Engine

The CUMMINS QSM11 electronic control engine combines full-authority electronic controls with the reliable performance. The combination of improved airflow and evenly dispersed fuel results in increased power, improved transient response and reduced fuel consumption. And the QSM11 uses advanced electronic controls to meet the emission standards. (EPA Tier-3, EU Stagell-A)

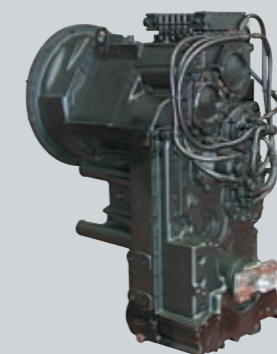

Full Automatic  
Transmission

Fully automatic transmission designed for maximum durability, Minimum power loss, improved travel speed and low noise. Improved clutch control and minimized shifting shock when traveling, contribute to a smoother ride. Error messages and transmission fault history are recorded and accessible through the monitor.

\*Photo may include optional equipment.



# Profitable

9 series is designed to maximize profitability through improved efficiencies, enhanced service features and longer life components.



## Hi-mate (Remote Management System)

Hi-mate, Hyundai's proprietary remote management system, provides operators and dealer service personnel access to vital service and diagnostic information on the machine from any computer with internet access. Users can pinpoint machine location using digital mapping and set machine work boundaries, reducing the need for multiple service calls. Hi-mate saves time and money for the owner and dealer by promoting preventative maintenance and reducing machine downtime.



## Remote-mounted Cooling Fan

The remote mounted, hydraulically powered cooling fan regulates fan speed according to working temperatures for coolant, intake air, transmission oil and hydraulic oil. This new fan design contributes to reduced fuel consumption and machine noise. The fan is designed to auto reverse periodically or manually reverse to keep debris from accumulating on the coolers.



## Easy Access

The engine fan is integrated into the rear door which swings open to over 45 degrees for easy access and regular maintenance. Conveniently located coolant and transmission oil site gauges make checking fluid levels fast and efficient. Ground-line access to fuel and oil filters, grease fittings, fuses, machine computer components and wide open compartments makes service more convenient on the 9 series.



## Full Fenders and Mud Guards (Option)

9 series wheel loaders can be equipped with optional full rear fenders and front and rear mud flaps to reduce material splatter to the cab and machine frame.



Hydraulic filter  
(1,000 hr)



Hydraulic Oil  
(5,000 hr)

## Extended Life Components

The 9 series is designed for reduced lubrication intervals and extended component life. Long life hydraulic filters now have 1,000 hours service intervals and Hyundai certified hydraulic oil can last up to 5,000 hours before changing. Also, a new center pivot roller bearing design, now double tapered, requires less maintenance as well. Long life and extended wear components save the operator time and money.

\*Photo may include optional equipment.

# Specifications & Dimensions

## ENGINE

|                  |   |
|------------------|---|
| Maker/Model      | CUMMINS QSM11   |
| Type             | 4-cycle, turbocharged, charge aircooled direct injection, electronic controlled diesel engine |
| Gross power      | 348HP(260 kW) / 2,000rpm  |
| Net power        | 344HP(257 kW) / 2,000rpm  |
| Maximum torque   | 171kg.m(1,235 lb.ft) / 1,400rpm   |
| No. of cylinders | 6   |

※No derating for continuous operating required up to 3,048m (10,000ft). This engine meets the EPA(Tier III) / EU(Stage III-A) Emission regulation.

|                   |                               |
|-------------------|-------------------------------|
| Bore x Stroke     | 125 mm (4.9") x 147 mm (5.8") |
| Displacement      | 10.8 l (660 cu in)            |
| Compression ratio | 16.3 : 1                      |
| Air cleaner       | Dry, dual elements            |
| Alternator        | 24V, 70 Amp                   |
| Battery           | 2 x 12V, 220 Ah.              |
| Starting motor    | 24V, 7.5 kW                   |

## TRANSMISSION

|                       |                                       |
|-----------------------|---------------------------------------|
| Torque converter type | 3-elements, single-stage Double-phase |
| Tire                  | 29.5-25, L3                           |

※Full automatic power shift, countershaft type with soft-shift in range and direction. Properly matched torque converter to engine and transmission for excellent working ability

| Travel speed |     | km/h (mph) |
|--------------|-----|------------|
| Forward      | 1st | 6.1(3.8)   |
|              | 2nd | 11.5(7.1)  |
|              | 3rd | 18.0(11.2) |
|              | 4th | 36.5(22.7) |
| Reverse      | 1st | 6.1(3.8)   |
|              | 2nd | 11.5(7.1)  |
|              | 3rd | 25.0(15.5) |

## AXLES

|                       |  |
|-----------------------|--|
| Drive system          | Four-wheel drive system                    |
| Mount                 | Rigid front axle and oscillating rear axle |
| Rear axle oscillation | ±13° (total 26°)                           |

|                 |                                    |
|-----------------|------------------------------------|
| Hub reduction   | Planetary reduction at wheel end   |
| Differential    | Front hyd. lock, rear conventional |
| Reduction ratio | 27.0                               |

## HYDRAULIC SYSTEM

|                 |   |
|-----------------|---|
| Type            | Load sensing hydraulic system   |
| Pump            | Variable axial piston pump, 420 liters/min (111.0 gal/min)@governed rpm                 |
| Control valve   | 2 Spool (Bucket, Boom)<br>3 Spool (Bucket, Boom, Aux)<br>Pilot pressure controlled type |
| System pressure | 280 kgf/cm <sup>2</sup> (3,982 psi)   |

|                 |              |  |
|-----------------|--------------|--|
| Bucket Controls | Type         | Pilot operated lift and tilt circuit, single-lever(joystick) control standard.   |
|                 | Lift Circuit | The valve has four functions ; raise, hold, lower and float. Can adjust automatic kickout from horizontal to full lift.  |
| Tilt Circuit    |              | The valve has three functions ; tilt back, hold and dump. Can adjust automatic bucket positioner to desired load angle.  |
|                 | Cylinder     | Type : Double acting Lift, bore x stroke 2-180 mm(7.0") x 863 mm(34.0") Tilt, bore x stroke HL780-9 2-140 mm(5.5") x 575 mm(22.6") HL780XTD-9 2-140 mm(5.5") x 570 mm(25.4") |
| Cycle Time      |              | Raise : 6.1 sec (with load)<br>Dump : 1.4 sec<br>Lower : 4.1 sec (empty)<br>Total : 11.6 sec   |

## BRAKES

|                 |  |
|-----------------|--|
| Service Brakes  | Hydraulically actuated, wet disc brakes actuate all 4 wheels, independent axle-by-axle system. Self adjusting & wheel speed brake. |
| Parking Brake   | Spring-applied, hydraulically released disc brake on front drive shaft.  |
| Emergency Brake | When brake oil pressure drops, indicator light alerts operator and parking brake automatically applies.                            |

## STEERING SYSTEM

|                      |  |
|----------------------|--|
| Steering Type        | Load sensing hydrostatic articulated steering                  |
| Pump                 | Piston, 220 liters/min (58.1 gal/min)                          |
| Relief Valve Setting | 210 kg/cm <sup>2</sup> (2,990 psi)                             |
| Cylinder             | Type Double acting<br>Bore x Stroke 105mm(4.1") x 480mm(18.9") |
| Steering Angle       | 40°(each direction)  |

Features  
- Center-point frame articulation. - Load-sensing, pressure-compensated system.  
- Steering-wheel operated metering pump controls flow to steering cylinders.  
- Tilt and telescopic steering column.

## SERVICE REFILL CAPACITIES

|                |                          |
|----------------|--------------------------|
| Fuel tank      | 450 liters (118.8 USgal) |
| Cooling system | 65 liters (17.2 USgal)   |
| Crankcase      | 38 liters (10.0 USgal)   |
| Transmission   | 43 liters (11.4 USgal)   |

## OVERVIEW

| Description           | UNIT      | HL780-9                                     | HL780XTD-9      |
|-----------------------|-----------|---|-----------------|
| Operating weight      | kg (lb)   | 30,000 (66,100)                             | 30,800 (67,900) |
| Bucket capacity       | Heaped    | m <sup>3</sup> (yd <sup>3</sup> ) 5.4 (7.1) | 5.4 (7.1)       |
|                       | Struck    | m <sup>3</sup> (yd <sup>3</sup> ) 4.6 (6.0) | 4.6 (6.0)       |
| Breakout force-bucket | kg (lb)   | 23,750 (52,360)                             | 23,130 (50,990) |
| Tipping load          | Straight  | kg (lb) 24,200 (53,350)                     | 21,500 (47,400) |
|                       | Full turn | kg (lb) 21,000 (46,300)                     | 18,500 (40,790) |

## TIRES

|                 |   |
|-----------------|---|
| Type            | Tubeless, loader design tires   |
| Standard        | 29.5-25, 22 PR, L3  |
| Options include | 26.5-25, 32 PR, L3<br>29.5-25, 28 PR, L3<br>29.5-25, 28 PR, L5<br>29.5 R25 XHA* |

## DIMENSIONS

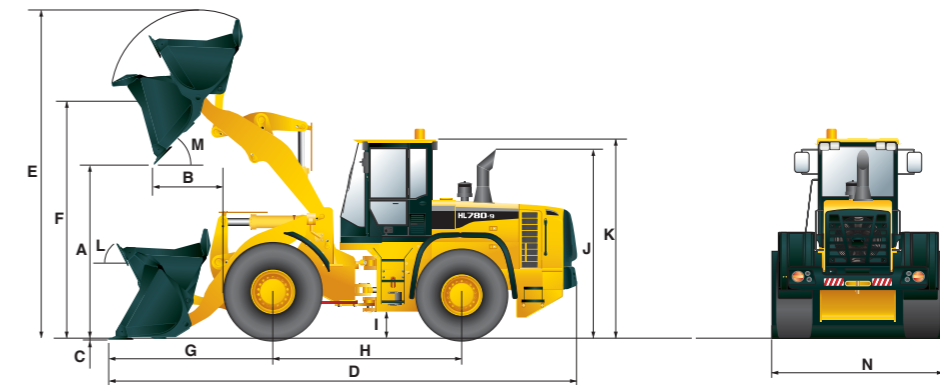

| Description   | UNIT                                 | HL780-9                   | HL780XTD-9      |
|---|--------------------------------------|---------------------------|-----------------|
| Bucket Type   | General purpose bolt-on cutting edge |                           |                 |
| A. Dumping clearance at max. height and 45° dump angle. | mm (ft-in)                           | 3,300 (10' 10")           | 3,670 (12')     |
| B. Reach  | Full lift                            | mm (ft-in) 1,430 (4' 8")  | 1,480 (4' 10")  |
|   | 7ft height                           | mm (ft-in) 2,150 (7' 1")  | 2,470 (7' 11")  |
| C. Digging depth  | mm (in)                              | 105 (4.1")                | 115 (4.5")      |
| D. Overall length                                       | on ground                            | mm (ft-in) 9,630 (31' 7") | 10,060 (33')    |
|   | at carry                             | mm (ft-in) 9,545 (31' 4") | 9,990 (32' 9")  |
| E. Overall height (fully raised)                        | mm (ft-in)                           | 6,295 (20' 8")            | 6,670 (21' 11") |
| F. Bucket pivot max. height                             | mm (ft-in)                           | 4,560 (15')               | 4,935 (16' 2")  |

| Description                             | UNIT           | HL780-9                   | HL780XTD-9      |
|---|----------------|---------------------------|-----------------|
| G. Front overhang                       | mm (ft-in)     | 3,200 (10' 6")            | 3,575 (11' 9")  |
| H. Wheelbase                            | mm (ft-in)     | 3,700 (12' 2")            | 3,700 (12' 2")  |
| I. Ground clearance                     | mm (ft-in)     | 495 (1' 7")               | 495 (1' 7")     |
| J. Height over exhaust                  | mm (ft-in)     | 3,310 (10' 10")           | 3,310 (10' 10") |
| K. Height over cab                      | mm (ft-in)     | 3,865 (12' 8")            | 3,865 (12' 8")  |
| L. Roll-back angle (on ground/at carry) | deg            | 42 / 48                   | 42 / 49         |
| M. Dump angle                           | deg            | 47                        | 47              |
| Clearance circle                        | mm (ft-in)     | 14,970 (49' 1")           | 15,310 (50' 3") |
| N. Overall width                        | with bucket    | mm (ft-in) 3,450 (11' 4") | 3,450 (11' 4")  |
|   | without bucket | mm (ft-in) 3,220 (10' 7") | 3,220 (10' 7")  |