

STANDARD EQUIPMENT

ISO Standard cabin
 All-weather steel cab with 360° visibility
 Safety glass windows
 Rise-up type windshield wiper
 Sliding fold-in front window
 Sliding side window(LH)
 Lockable door
 Hot & cool box
 Storage compartment & Ashtray
 Transparent cabin roof-cover
 Radio / USB player
 Handsfree mobile phone system with USB
 Sun visor
 12 volt power outlet (24V DC to 12V DC converter)
 Computer aided power optimization (New CAPO) system
 3-power mode, 2-work mode, User mode
 Auto deceleration & one-touch deceleration system
 Auto warm-up system
 Auto overheat prevention system
 Automatic climate control
 Air conditioner & heater
 Defroster
 Self-diagnostics system
 Starting Aid (air grid heater) for cold weather
 Centralized monitoring
 LCD display
 Engine speed or Trip meter/Accel.
 Clock
 Gauges
 Fuel level gauge
 Engine coolant temperature gauge
 Hyd. oil temperature gauge
 Warnings
 Check Engine
 Communication error
 Low battery
 Air cleaner clogging
 Indicators
 Power max
 Fuel warmer
 Auto idle
 Door and cab locks, one key
 Two outside rearview mirrors
 Mechanical suspension seat with heater
 Pilot-operated slidable joystick
 Console box height adjust system
 Four front working lights
 Electric horn
 Batteries (2 x 12V x 100 AH)
 Battery master switch
 Removable clean-out screen for oil cooler
 Automatic swing brake
 Removable reservoir tank
 Fuel pre-filter with fuel warmer
 Boom holding system
 Arm holding system
 Track shoes (600mm, 24")
 Track rail guard
 Accumulator for lowering work equipment
 Electric transducer
 Lower frame under cover (Normal)
 Viscous fan clutch

OPTIONAL EQUIPMENT

Fuel filler pump (50 L/min)
 Beacon lamp
 Safety lock valve for boom cylinder with overload warning device
 Safety lock valve for arm cylinder
 Single-acting piping kit (breaker, etc.)
 Double-acting piping kit (clamshell, etc.)
 Quick coupler
 Travel alarm
 Arms
 2.00 m, 6' 7"
 2.40 m, 7' 10"
 2.92 m, 9' 7"
 Cabin lights
 Cabin front window rain guard
 Track shoes
 700mm, 28"
 800mm, 32"
 900mm, 36"
 Lower frame under cover (Additional)
 Long crawler lower frame
 Tool kit
 Operator suit
 Rearview camera
 Pattern change valve (2 patterns)
 Hi-mate (Remote Management System)
 Cabin FOPS/FOG (ISO/DIS 10262)-Level II
 FOPS (Falling Object Protective Structure)
 FOG (Falling Object Guard)

* Standard and optional equipment may vary. Contact your Hyundai dealer for more information. The machine may vary according to national standards.
 * The photos may include attachments and optional equipment that are not available in your area.
 * Materials and specifications are subject to change without advance notice.
 * All imperial measurements rounded off to the nearest pound or inch.

PLEASE CONTACT

www.hyundai-ce.com

2010. 12 Rev. 0

HYUNDAI
 HEAVY INDUSTRIES CO.,LTD.
CONSTRUCTION EQUIPMENT

Office (Sales Office)
 1 JEONHA-DONG, DONG-GU, ULSAN, KOREA TEL: (82) 52-202-7970, 7729, 0971 FAX: (82) 52-202-7979, 7720
 Americas Operation: Hyundai Construction Equipment Americas, Inc.
 955 ESTES AVENUE, ELK GROVE VILLAGE, IL. 60007, U.S.A. TEL: (1) 847-437-3333 FAX: (1) 847-437-3574
 Europe Operation: Hyundai Heavy Industries Europe N.V.
 VOSSENDAAL 11, 2440 GEEL, BELGIUM TEL: (32) 14-56-2200 FAX: (32) 14-59-3405
 India Operation: Hyundai Construction Equipment India Pvt., Ltd.
 PLOT NO.A-2, CHAKAN INDUSTRIAL AREA, VILL.- KHALUMBRE. TALUK.- KHED., DIST.- PUNE 410 501, INDIA
 TEL: (91) 21-3530-1700 FAX: (91) 21-3530-1712

We build a better future

Robex
235LCR-9

With Tier 3 Engine installed



*Photo may include optional equipment.

HYUNDAI
 HEAVY INDUSTRIES CO.,LTD.

Pride at Work

Hyundai Heavy Industries strives to build state-of-the-art earthmoving equipment to give every operator maximum performance, more precision, versatile machine preferences, and proven quality. Take pride in your work with Hyundai!

Robex 235LCR-9

Machine Walk-Around

Undercarriage

Sealed track chain (urethane seals) / Standard track rail guard / Comfortable bolt-on steps
Large upper roller cut-outs for debris clean-out / Tapered side frames for debris clean-out / Grease-type track tensioner

Engine Technology

Powerful / reliable, fuel efficient Cummins QSB6.7 engine
Electronically controlled for optimum fuel to air ratio and clean, efficient combustion
Low noise / Auto engine overheat feature / Anti-restart feature

Hydraulic System Improvements

New patented hydraulic control for improved controllability / Improved control valve design for added efficiency and smoother operation / New auto boom and swing priority system for optimum speed / New auto power boost feature for additional power when needed / Improved arm-in and boom-down flow regeneration system for added speed and efficiency

Pump Compartment

Industry-leading, powerful, reliable Kawasaki designed, variable volume in-line axial piston pumps
New compact solenoid block equipped with 3 solenoid valves, 1 EPPR valve, 1 check valve accumulator and line filter controls
2 speed travel, power boost, boom priority, arm-in regeneration, safety lock

Enhanced Operator Cab

Improved Visibility

Enlarged cab with improved visibility / See-through upper skylight for visibility and ventilation
Larger right-side glass - now one piece, for better right visibility
Safety glass windows on all sides - less expensive than (polycarbonate) and won't scratch or fade
Closeable sunshade for operator convenience / Reduced front window seam for improved operator view

Improved Cab Construction

New steel tube construction for added operator safety, protection and durability
New window open/close mechanism designed with cable and spring lift assist and single latch release

Improved Suspension Seat / Console Assembly

Ergonomic joysticks with auxiliary control buttons for attachment use. Now with new sleek styling
Adjustable heated suspension seat, control console and arm rests

Advanced 7" Color Cluster

New Color LCD Display with easy-to-read digital gauges for hydraulic oil temperature, water temperature, and fuel. A simplified design makes adjustment and diagnostics easier. Also, new enhanced features such as rear-view camera are integrated into monitor.

3 power modes : (P) Power, (S) Standard, (E) Economy, 2 work modes : Dig & Attachment, (U) User mode for operator preference
Enhanced self-diagnostic features with GPS download capability
One pump flow or two pump flow for optional attachment now selectable through the cluster / New anti-theft system with password capability
Boom speed and arm regeneration are selectable through the monitor.
Auto power boost is now available - selectable (on/off) through the monitor.
Powerful air conditioning and heat with auto climate control, 20% more heat and air output than 7A series!
RMS (Remote Management System) works through GPS/satellite technology to ultimately provide better customer service and support.

Preference

Operating the R235LCR-9 is unique to every operator. Operators can fully customize their work environment and operating preferences to fit their individual needs.



*Photo may include optional equipment.



Wide Cab with Excellent Visibility

The newly designed cab was conceived for more space, a wider field of view and operator comfort. Special attention was given to a clear, open and convenient interior with plenty of visibility on the machine surroundings and the job at hand. This well balanced combination of precision aspects put the operator in the perfect position to work safely and securely.

Operator Comfort

In the 9 series cab, you can easily adjust the seat, console and armrest settings to best suit your personal operating preferences. Seat and console position can be set together and independently from each other. Additional creature comforts include the fully automatic high capacity air conditioning system and the radio / USB player.



Reduced Stress

Work is stressful enough. Your work environment should be stress free. Hyundai's 9 series provides improved cab amenities, additional space and a comfortable seat to minimize stress to the operator. A powerful climate control system provides the operator with optimum air temperature. An advanced audio system with USB player, AM/FM stereo and, plus remotely located controls is perfect for listening to music favorites. Operators can even talk on the phone with the hands-free cell phone feature.



Operator - Friendly Cluster

The advanced new cluster with 7 inch wide color LCD screen and toggle switch allows the operator to select his personal machine preferences. Power and work mode selection, self diagnostics, optional rear-view camera, maintenance check lists, start-up machine security, and video functions were integrated into the cluster to make the machine more versatile and the operator more productive.



Precision

Innovative hydraulic system technologies make the 9 series excavator fast, smooth and easy to control.



*Photo may include optional equipment.

Computer Aided Power

The engine horsepower and hydraulic horsepower together in unison through the advanced CAPO(Computer Aided Power Optimization) system, provide the precise flow needed for the job at hand. Operators can set their own preferences for boom swing priority, power mode selection and optional work tools at the touch of a button. The CAPO system also provides complete self diagnostic features and digital gauges for important information like hydraulic oil temperature, water temperature and fuel level. This system interfaces with multiple sensors placed throughout the hydraulic system as well as the electronically controlled engine to provide the optimum level of engine power and hydraulic flow.

Power Mode

P (Power Max) mode maximizes machine speed and power for mass production. S (Standard) mode provides a reduced, fixed rpm for optimum performance and improved fuel economy. For maximum fuel savings and improved control, E (Economy) mode provides precise flow and engine power based on load demand. Three unique power modes provide the operator with custom power, speed and fuel economy.

Work Mode

The work mode allows the operator to select single flow attachments like a hydraulic breaker or bi-directional flow attachments like a crusher. Flow settings unique to each attachment can be programmed from within the cluster.

User Mode

Some jobs require more precise machine settings. Using the versatile U (User) mode, the operator can customize engine speed, pump output, idle speed and other machine settings for the job at hand.

Improved Hydraulic System



To achieve optimum precision, Hyundai redesigned the hydraulic system to provide the operator with super fine touch and improved controllability. Improved pump flow control reduces flow when controls are not being used to minimize fuel consumption.

Improved spool valves in the control valve are engineered to provide more precise flow to each function with less effort.

Improved hydraulic valves, precision-designed variable volume piston pumps, fine-touch pilot controls, and enhanced travel functions make any operator running a 9

series look like a smooth operator. Newly improved features

include arm-in and boom-down flow regeneration, improved control valve technology and innovative auto boom and swing priority for optimal performance in any application.

Auto Boom & Swing Priority

This smart function automatically and continuously looks the ideal hydraulic flow balance for the boom and swing motions of the machine. The advanced CAPO system monitors the hydraulic system and adjusts its settings to maximize performance and productivity.



Performance

9 series is designed for maximum performance to keep the operator working productively.



Track Rail Guard & Adjusters

in place. Track adjustment is made easy with standard grease cylinder track adjusters and shock absorbing springs.

Durable track rail guards keep track links

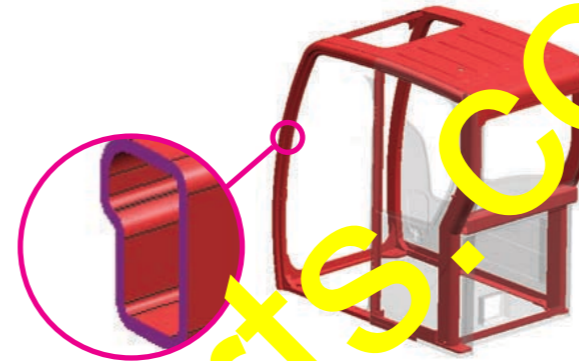

Structure Strength

The 9 series cab structure has been fitted with stronger but slimmer tubing for more safety and improved visibility. Low-stress high-strength steel is integrally welded to form a stronger, more durable upper and lower frame. Structural integrity was tested by way of FEM (Finite Elements Method) analysis and long-term durability tests.

Eco-friendly Cummins QSB 6.7 Engine

The CUMMINS QSB6.7 engine combines advanced electronic controls and a self-diagnostic system with reliable performance. The combination of a high pressure common rail system and an advanced in-cylinder combustion technology results in increased power, improved transient response and reduced fuel consumption. The QSB6.7 Cummins engine complies with current emissions standards including EPA Tier3 and EU Stage III-A.

The Definition of Progress

The Quantum System B Series 6.7-liter engine combines full authority electronic controls with the reliable performance. The electronics with the QSB6.7 have been proven with our high-horsepower products working in the harshest, most demanding environments - search as dusty, non-stop mining operations while meeting emissions regulations worldwide.

The QSB6.7 features 24 valve designed with centered injectors and symmetrical piston bowl. The combination of improved airflow and evenly dispersed fuel results in increased power, improved transient response and reduced fuel consumption.

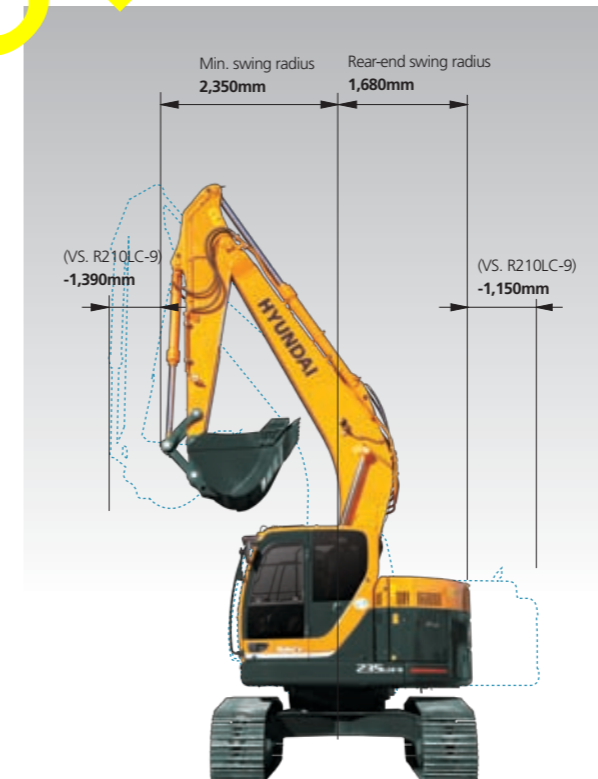

Excellent Performance in Confined Areas

R235LCR-9's short (1,680mm) tail swing radius allows the operator work in confined areas like close to buildings on roadways, and in urban areas. This Compact radius design provides easy and efficient operation in any limited space work environment.



*Photo may include optional equipment.

Profitability

9 series is designed to maximize profitability through improved efficiencies, enhanced service features and longer life components.



Fuel Efficient

9 series excavators are engineered to be extremely fuel efficient. New innovations like two-stage auto decel system and the new economy mode help to conserve fuel and reduce the impact on the environment.



Hi-mate (Remote Management System)

Hi-mate, Hyundai's proprietary remote management system, provides operators and dealer service personnel access to vital service and diagnostic information on the machine from any computer with internet access. Users can pinpoint machine location using digital mapping and set machine work boundaries, reducing the need for multiple service calls. Hi-mate saves time and money for the owner and dealer by promoting preventative maintenance and reducing machine downtime.



Easy Access

Ground-line access to filters, lube fittings, fuses, machine computer components and wide open compartments makes service more convenient on the 9 series.

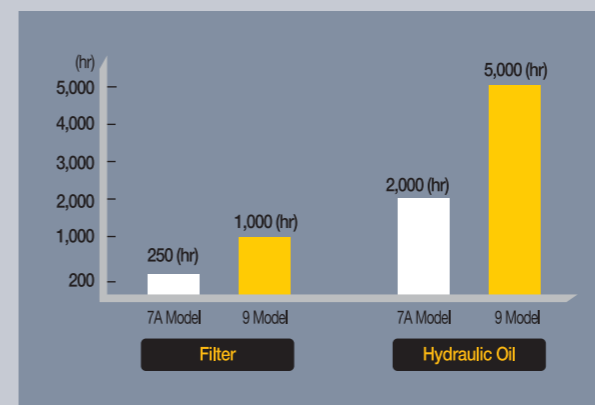

Extended Life Components

9 series excavators were designed with bushings designed for extended lube intervals (250 hrs) & polymer shims (wear resistant, noise reducing), extended-life hydraulic filters (1,000hrs), long-life hydraulic oil (5,000hrs), more efficient cooling systems and integrated preheating systems which extend service intervals, minimize operating costs and reduce machine down time.

*Photo may include optional equipment.

Specifications

ENGINE

MODEL	CUMMINS QSB6.7 Engine		
Type	Water cooled, 4 cycle Diesel, 6-cylinders in line, direct injection, turbocharged charger and air cooled		
Rated flywheel horse power	SAE	J1995 (gross)	151HP (113kW)/ 1,900 rpm
		J1349 (net)	143HP (107kW)/ 1,900 rpm
DIN		6271/1 (gross)	153PS (113kW)/ 1,900 rpm
		6271/1 (net)	145PS (107kW)/ 1,900 rpm
Max. torque	63.6kgf·m (460lbf·ft)/1,500rpm		
Bore X stroke	107mm X 124mm (4.2" X 4.9")		
Piston	6,700cc (409 in ³)		
Batteries	2 X 12V X 100AH		
Starting motor	24V, 4.5kW		
Alternator	24V, 70Amp		

HYDRAULIC SYSTEM

MAIN PUMP	
Type	Variable displacement tandem axis piston pumps
Rated flow	2 X 222 L/min (58.6 US gpm/48.8 UK gpm)
Sub-pump for pilot circuit	Gear pump
Cross-sensing and fuel saving pump system.	

HYDRAULIC MOTORS

Travel	Two speed axial pistons motor with brake valve and parking brake
Swing	Axial piston motor with automatic brake

RELIEF VALVE SETTING

Implement circuits	350 kgf/cm ² (4,980 psi)
Travel	350 kgf/cm ² (4,980 psi)
Power boost (boom, arm, bucket)	380 kgf/cm ² (5,410 psi)
Swing circuit	285 kgf/cm ² (4,050 psi)
Pilot circuit	40 kgf/cm ² (570 psi)
Service valve	Installed

HYDRAULIC CYLINDERS

No. of cylinder	Boom: 2-120 X 1,290 mm (4.7" X 50.8")
bore X stroke	Arm: 1-140 X 1,510 mm (5.5" X 59.4")
	Bucket: 1-120 X 1,055 mm (4.7" X 41.5")

DRIVES & BRAKES

Drive method	Fully hydrostatic type
Drive motor	Axial piston motor, in-shoe design
Reduction system	Planetary reduction gear
Max. drawbar pull	21,100 kgf (46,517 lbf)
Max. travel speed(high) / (low)	5.3 km/hr (3.3mph) / 3.4 km/hr (2.1mph)
Gradeability	30° (58 %)
Parking brake	Multi wet disc

CONTROL

Pilot pressure operated joysticks and pedals with detachable lever provide almost effortless and fatigueless operation.

Pilot control	Two joysticks with one safety lever (LH): Swing and arm, (RH): Boom and bucket(ISO)
Traveling and steering	Two levers with pedals
Engine throttle	Electric, Dial type

SWING SYSTEM

Swing motor	Fixed displacement axial piston motor
Swing reduction	Planetary gear reduction
Swing bearing lubrication	Grease-bathed
Swing brake	Multi wet disc
Swing speed	10.7 rpm

COOLANT & LUBRICANT CAPACITY

Refilling	liter	US gal	UK gal
Fuel tank	320	84.5	70.4
Engine coolant	35	9.2	7.7
Engine oil	24	6.3	5.3
Swing device-gear oil	5	1.3	1.1
Final drive(each)-gear oil	5.8	2	1
Hydraulic system(including tank)	275	72.6	60.5
Hydraulic tank	160	42.3	35.2

UNDERCARRIAGE

The X-leg type center frame is integrally welded with reinforced box-section track frames. The undercarriage includes lubricated rollers, idlers, track adjusters with shock absorbing springs and sprockets, and a track chain with double or triple grouser shoes.

Center frame	X - leg type
Track frame	Pentagonal box type
No. of shoes on each side	49 EA
No. of carrier roller on each side	2 EA
No. of track roller on each side	9 EA
No. of rail guard on each side	2 EA

OPERATING WEIGHT (APPROXIMATE)

Operating weight, including 5,680mm (18' 8") boom, 2,920mm (9' 7") arm, SAE heaped 0.80m³ (1.05 yd³) bucket, lubricant, coolant, full fuel tank, full hydraulic tank, and all standard equipments.

MAJOR COMPONENT WEIGHT

Upperstructure	
Boom(with arm cylinder)	1,950 kg (4,300 lb)
Arm(with bucket cylinder)	1,095 kg (2,415 lb)

OPERATING WEIGHT

Shoes		Operating weight	Ground pressure
Type	Width mm(in)	kg(lb)	kgf/cm ² (psi)
Triple grouser	600 (24")	24,150 (53,240)	0.51 (7.25)
	700 (28")	24,150 (53,240)	0.44 (6.26)
	800 (32")	24,415 (53,830)	0.39 (5.55)
	900 (35")	24,680 (54,410)	0.35 (4.98)

BUCKETS

All buckets are welded with high-strength steel.

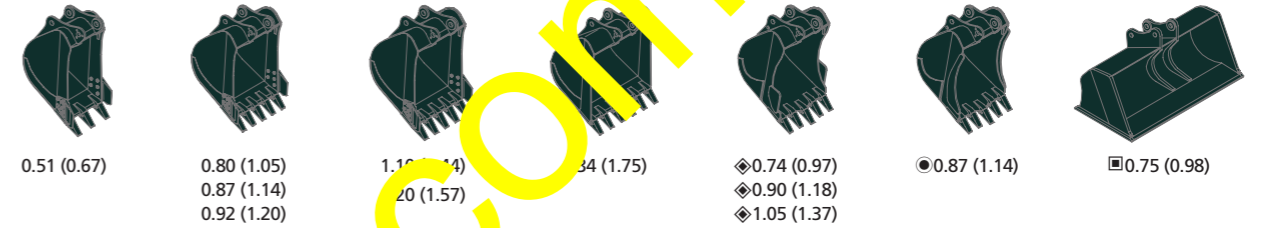

Capacity m ³ (yd ³)	Width mm (in)	Weight kg (lb)	Recommendation mm (ft-in)		
			5,680 (18' 8") Boom		
SAE heaped	CECE heaped	Without side cutters	2,000 (6' 7") Arm	2,400 (7' 10") Arm	2,920 (9' 7") Arm
0.51 (0.67)	0.45 (0.59)	700 (1,540)	●	●	●
0.80 (1.05)	0.70 (0.92)	1,000 (2,200)	●	●	●
0.87 (1.14)	0.75 (0.98)	1,050 (2,310)	●	●	■
0.92 (1.20)	0.80 (1.05)	1,100 (2,420)	●	●	■
1.10 (1.44)	0.96 (1.26)	1,320 (2,900)	●	▲	▲
1.20 (1.57)	1.00 (1.31)	1,400 (3,080)	■	▲	—
1.34 (1.75)	1.15 (1.50)	1,500 (3,300)	▲	▲	—
◆ 0.74 (0.97)	0.65 (0.87)	980 (2,150)	●	●	●
◆ 0.90 (1.18)	0.75 (1.02)	1,170 (2,580)	●	●	■
◆ 1.05 (1.37)	0.92 (1.20)	1,290 (2,840)	●	■	▲
● 0.87 (1.14)	0.75 (0.98)	1,140 (2,510)	●	●	■
◆ 1.05 (1.37)	0.85 (1.13)	1,790 (3,940)	●	●	■

◆ Heavy duty bucket
● Rock-Havy duty bucket
■ Slope finishing bucket

●: Applicable for materials with density of 2,000 kg/m³ (3,370 lb/ yd³) or less
■: Applicable for materials with density of 1,600 kg/m³ (2,700 lb/ yd³) or less
▲: Applicable for materials with density of 1,100 kg/m³ (1,850 lb/ yd³) or less

ATTACHMENT

Booms and arms are welded with a low-stress, full-box section design. 5.68m Boom and 2.0m, 2.4m, 2.92m Arms are available.

DIGGING FORCE

Boom	Length	mm (ft-in)	5,680 (18' 8")			Remarks
			Weight	kg (lb)	kgf/cm ² (psi)	
Arm	Length	mm (ft-in)	2,000 (6' 7")	2,400 (7' 10")	2,920 (9' 7")	
	Weight	kg (lb)	975 (2,150)	1,045 (2,300)	1,095 (2,410)	
Bucket digging force	SAE	kN	133.4 [145.5]	133.4 [145.5]	133.4 [145.5]	[]: Power Boost
		kgf	13600 [14840]	13600 [14840]	13600 [14840]	
		lbf	29980 [32710]	29980 [32710]	29980 [32710]	
	ISO	kN	152.0 [165.8]	152.0 [165.8]	152.0 [165.8]	
		kgf	15500 [16910]	15500 [16910]	15500 [16910]	
		lbf	34170 [37280]	34170 [37280]	34170 [37280]	
Arm crowd force	SAE	kN	144.2 [156.5]	119.6 [129.9]	102.0 [110.7]	
		kgf	14700 [15960]	12200 [13250]	10400 [11290]	
		lbf	32410 [35190]	26900 [29210]	22930 [24900]	
	ISO	kN	151.0 [164.0]	125.5 [136.3]	106.9 [116.1]	
		kgf	15400 [16720]	12800 [13900]	10900 [11830]	
		lbf	33950 [36860]	28220 [30640]	24030 [26090]	

Note: Boom weight includes arm cylinder, piping, and pin
Arm weight includes bucket cylinder, linkage, and pin

Dimensions & Working Range

R235LCR-9 DIMENSIONS

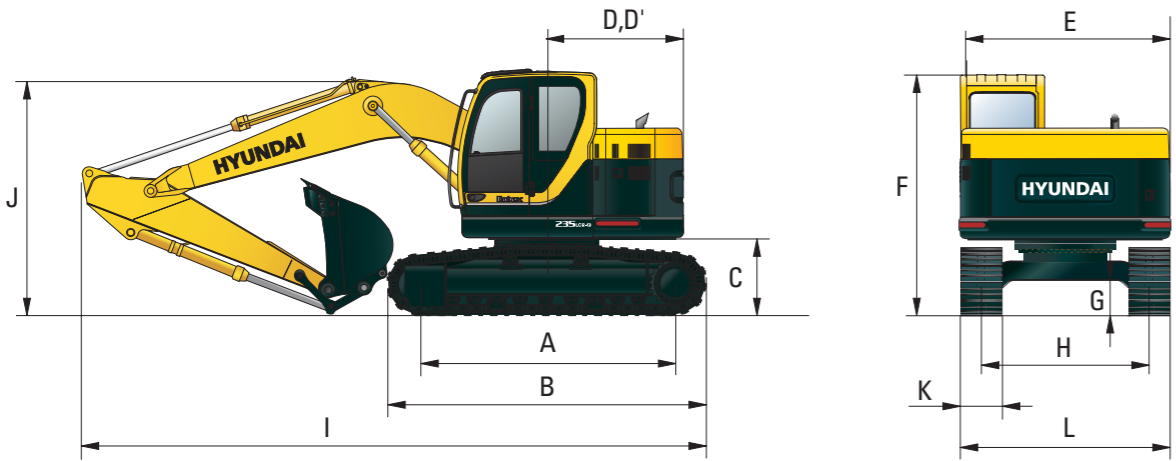

Dimension	Value (mm)	Value (ft-in)
A Tumbler distance	3,650	11' 12"
B Overall length of crawler	4,440	14' 7"
C Ground clearance of counterweight	1,060	3' 6"
D Tail swing radius	1,680	5' 6"
D' Rear-end length	1,680	5' 6"
E Overall width of upperstructure	2,980	9' 9"
F Overall height of cab	2,950	9' 8"
G Min. ground clearance	480	1' 7"
H Track gauge	2,390	7' 10"

R235LCR-9 WORKING RANGE

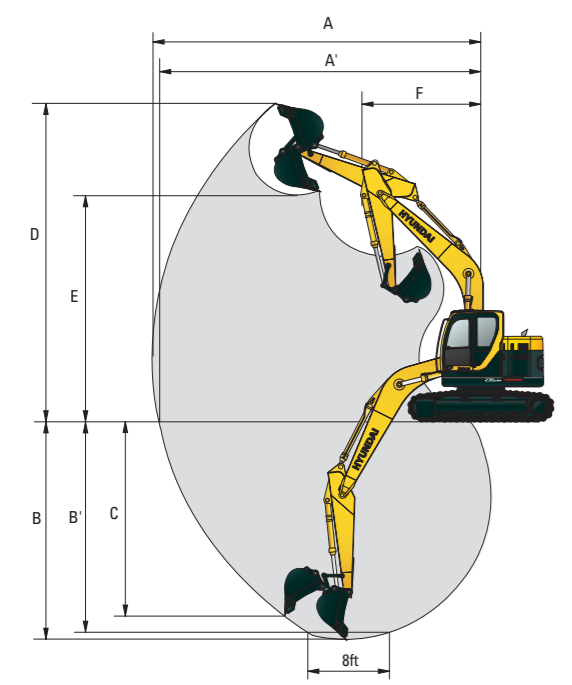

Dimension	Value (mm)	Value (ft-in)
Boom length	5,680	18' 8"
Arm length	2,000	6' 7"
A Max. digging reach	9,040	29' 8"
A' Max. digging reach on ground	8,860	29' 1"
B Max. digging depth	5,780	18' 12"
B' Max. digging depth (8' level)	5,550	18' 3"
C Max. vertical wall digging depth	5,140	16' 10"
D Max. digging height	10,090	33' 1"
E Max. dumping height	7,510	24' 8"
F Min. swing radius	2,860	9' 5"

Lifting Capacity

R235LCR-9

Rating over-front Rating over-side or 360 degree

Boom : 5.68 m (18' 8") / Arm : 2.0 m (6' 7") / Bucket : 0.80 m (1.05yd) SAE heaped / Shoe : 600mm(24") triple grouser

Load point height m (ft)	Load radius								At max. reach		
	3.0 m (10 ft)		4.5 m (15 ft)		6.0 m (20 ft)		7.5 m (25 ft)		Capacity	Reach	
10.5 m (35 ft)	kg								*4210	*4210	4.63
	lb								*9280	*9280	(15.2)
9.0 m (30 ft)	kg								*4630	*4630	4.48
	lb								*10210	*10210	(14.7)
7.5 m (25 ft)	kg			*4820	*4820				*4150	*4150	6.56
	lb			*10630	*10630				*9150	*9150	(21.5)
6.0 m (20 ft)	kg			*4980	*4980	*4590	*4590		*4050	3060	7.70
	lb			*10980	*10980	*10120	*10120		*8930	6750	(25.3)
4.5 m (15 ft)	kg	*8350	*8350	*5930	*5930	*4910	4570		*4050	2560	8.36
	lb	*18410	*18410	*13070	*13070	*10820	10080		*8930	5640	(27.4)
3.0 m (10 ft)	kg			*7310	6760	*5490	4310	*4620	*4080	2320	8.67
	lb			*16120	14900	*12100	9500	*10190	*8990	5110	(28.4)
1.5 m (5 ft)	kg			*1810	6250	*6040	4070	*4820	*4130	2270	8.66
	lb			*4000	13780	*13320	8970	*10630	*9110	5000	(28.4)
Ground	kg			*810	6020	*6300	3910		*4150	2390	8.36
	lb			*1800	13270	*13890	8620		*9150	5270	(27.4)
-1.5 m (-5 ft)	kg	*11480	*11480	*8320	5980	*6110	3860		*4070	2760	7.69
	lb	*25310	*25310	*18340	13180	*13470	8510		*8970	6080	(25.2)
-3.0 m (-10 ft)	kg	*9710	*9710	*7190	6090	*5140	3950		*3660	3660	6.55
	lb	*21410	*21410	*15850	13430	*11330	8710		*8070	8070	(21.5)

Boom : 5.68 m (18' 8") / Arm : 2.0 m (7' 10") / Bucket : 0.80 m (1.05 yd) SAE heaped / Shoe : 600mm(24") triple grouser

Load point height m (ft)	Load radius								At max. reach					
	1.5 m (5 ft)		3.0 m (10 ft)		4.5 m (15 ft)		6.0 m (20 ft)		7.5 m (25 ft)		Capacity	Reach		
9.0 m (30 ft)	kg										*4110	*4110	5.25	
	lb										*9060	*9060	(17.2)	
7.5 m (25 ft)	kg					*4280	*4280				*3820	3670	7.07	
	lb					*9440	*9440				*8420	8090	(23.2)	
6.0 m (20 ft)	kg					*4500	*4500	*4220	*4220		*3760	2780	8.12	
	lb					*9920	*9920	*9300	*9300		*8290	6130	(26.6)	
4.5 m (15 ft)	kg			*7270	*7270	*5450	*5450	*4600	*4600	*3950	3080	*3770	2350	8.74
	lb			*16030	*16030	*12020	*12020	*10140	*10140	*8710	6790	*8310	5180	(28.7)
3.0 m (10 ft)	kg			*11380	*11380	*6850	*6850	*5230	4350	*4420	2980	*3820	2150	9.04
	lb			*25090	*25090	*15100	*15100	*11530	9590	*9740	6570	*8420	4740	(29.7)
1.5 m (5 ft)	kg			*8100	6310	*5840	4080	*4690	2850	*3850	2090	9.03		
	lb			*17860	13910	*12870	8990	*10340	6280	8490	4610	(29.6)		
Ground	kg			*9120	*9120	*8640	6000	*6210	3890	*4820	2750	*3930	2190	8.74
	lb			*20110	*20110	*19050	13230	*13690	8580	*10630	6060	*8660	4830	(28.7)
-1.5 m (-5 ft)	kg	*9720	*9720	*12220	11860	*8450	5920	*6160	3810		*3900	2490	8.12	
	lb	*21430	*21430	*26940	26150	*18630	13050	*13580	8400		*8600	5490	(26.6)	
-3.0 m (-10 ft)	kg	*14180	*14180	*10550	*10550	*7550	5990	*5480	3850		*3650	3190	7.06	
	lb	*31260	*31260	*23260	*23260	*16640	13210	*12080	8490		*8050	7030	(23.2)	
-4.5 m (-15 ft)	kg			*7670	*7670	*5530	*5530							
	lb			*16910	*16910	*12190	*12190							

Boom : 5.68 m (18' 8") / Arm : 2.92 m (9' 7") / Bucket : 0.80 m (1.05 yd) SAE heaped / Shoe : 600mm(24") triple grouser

Load point height m (ft)	Load radius								At max. reach					
	1.5 m (5 ft)		3.0 m (10 ft)		4.5 m (15 ft)		6.0 m (20 ft)		7.5 m (25 ft)		Capacity	Reach		
9.0 m (30 ft)	kg					*2970	*2970				*3630	*3630	6.12	
	lb					*6550	*6550				*8000	*8000	(20.1)	
7.5 m (25 ft)	kg							*3310	*3310		*3460	3180	7.70	
	lb							*7300	*7300		*7630	7010	(25.3)	
6.0 m (20 ft)	kg							*3780	*3780		*3430	2480	8.66	
	lb							*8330	*8330		*7560	5470	(28.4)	
4.5 m (15 ft)	kg					*4810	*4810	*4190	*4190	*3860	3140	*3460	2120	9.24
	lb					*10600	*10600	*9240	*9240	*8510	6920	*7630	4670	(30.3)
3.0 m (10 ft)	kg			*9730	*9730	*6240	*6240	*4860	4410	*4150	3000	*3520	1940	9.52
	lb			*21450	*21450	*13760	*13760	*10710	9720	*9150	6610	*7760	4280	(31.2)
1.5 m (5 ft)	kg			*9500	*9500	*7650	6410	*5560	4110	*4490	2850	3520	1890	9.52
	lb			*20940	*20940	*16870	14130	*12260	9060	*9900	6280	7760	4170	(31.2)
Ground	kg			*9890	*9890	*8460	6010	*6050	3880	*4720	2730	*3650	1960	9.24
	lb			*21800	*21800	*18650	13250	*13340	8550	*10410	6020	*8050	4320	(30.3)
-1.5 m (-5 ft)	kg	*8800	*8800	*12860	11680	*8530	5850	*6160	3760	*4690	2660	*3670	2190	8.66
	lb	*19400	*19400	*28350	25750	*18810	12900	*13580	8290	*10340	5860	*8090	4830	(28.4)
-3.0 m (-10 ft)	kg	*12230	*12230	*11440	*11440	*7900	5870	*5740	3750		*3560	2720	7.69	
	lb	*26960	*26960	*25220	*25220	*17420	12940	*12650	8270		*7850	6000	(25.2)	
-4.5 m (-15 ft)	kg			*8990	*8990	*6360	6050				*2980	*2980	6.11	
	lb			*19820	*19820	*14020	13340				*6570	*6570	(20.0)	

- Lifting capacity is based on SAE J1097, ISO 10567.
- Lifting capacity of the Robex Series does not exceed 75% of the tipping load with the machine on firm, level ground or 87% of full hydraulic capacity.
- The load point is a hook located on the back of the bucket.
- (*) indicates the load limited by hydraulic capacity.