

PARTS & SERVICE NEWS

REF NO.	A910117
DATE	May 24, 1991

Page 1 of 12

SUBJECT: ADDITION OF SCREENING PLATES IN HYDRAULIC COMPONENT AREA ON WA700-1

PURPOSE: To introduce how to add screening plates to WA700-1

APPLICATION: WA700-1 Wheel Loaders, Serial Nos. 10001 thru 10076 (Except 10065)

DESCRIPTION:

1. Introduction

This PARTS & SERVICE NEWS introduces how to add screening plates to the vicinities of the engine room on the WA700-1 Wheel Loader in order to prevent the oil leaked from the hydraulic equipment tube from being splashed into the engine room.

Note: The screening plates have already been added to the machines that haven't been shipped yet.

2. List of additional parts

Part No.	Part Name	Qty	Purpose of part	Remarks	
428-54-12990	PLATE	2		For mounting the air cleaner front cover	
428-54-12960	PLATE	1		} Weld to the angle on the bulkhead panel catch	
428-54-12970	PLATE	1			
428-54-11930	RUBBER	1	} Install to the angle		
428-54-12940	PLATE	1			
428-54-12950	RUBBER	2			
427-54-13880	PLATE	8			
427-54-12940	COVER	1			Air cleaner front cover
01010-51230	BOLT	4	} Additional		
01643-31232	WASHER	9			
415-46-11370	SPACER	4			
415-46-11380	RUBBER	4			
01640-22440	WASHER	4			} For mounting the cover
01010-51220	BOLT	3			
428-54-11950	RUBBER	1			
428-54-11960	PLATE	1			
428-54-11990	RUBBER	1			
428-54-12910	RUBBER	1			

Part No.	Part Name	Q'ty	Purpose of part	Remarks
427-54-13890	PLATE	4	Additional	For mounting the cover
04050-13020	PIN	52		
428-54-12980	PLATE	1		
01010-51250	BOLT	1		Add these to the partition plate
01010-51245	BOLT	1		
01580-11210	NUT	2		
428-54-11820	RUBBER	1		
428-54-11861	RUBBER	1		
428-54-11870	RUBBER	1		Install these to the partition plate
428-54-11880	RUBBER	1		
428-54-11840	PLATE	2		
428-54-11830	PLATE	1		
428-54-11850	PLATE	4		

3. Improvements

Rubber plates are added to the current screening plate and also a hinged plate added to the air cleaner bottom as shown.

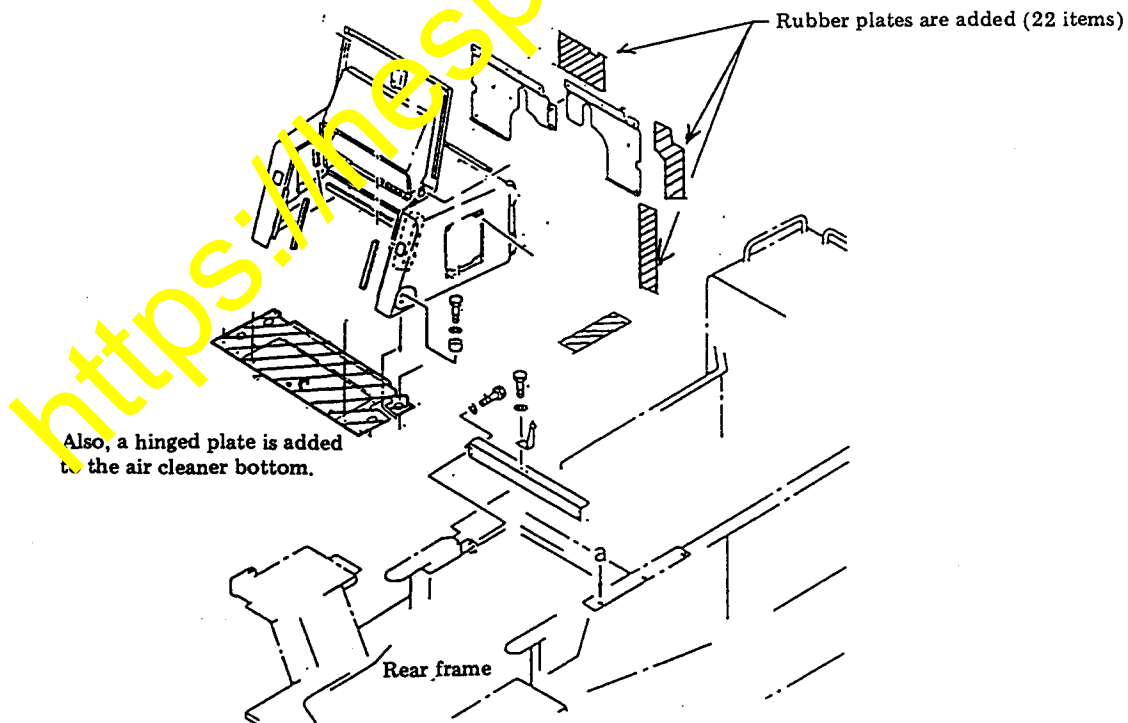

4. How to modify
Modify the parts marked ☆.
(For the details, see pp. 4 – 8)

Note: The bolts and nuts
must be reused.

☆428-54-11322 (R.H)

To modify, do not remove this part.
If done so, the working hours can be
cut down because of no removing
and reinstalling the part.

☆428-54-11312(L.H)

To modify, do not remove
this part. If done so, the
working hours can be
cut down because of no
removing and reinstalling
the part.

☆428-54-11541

☆428-54-11671

To modify, do not remove this part.
If done so, the working hours can be
cut down because of no removing
and reinstalling the part.

☆428-54-11571
(L.H)

☆428-54-11362 (L.H)

To modify, do not remove this part.
If done so, the working hours can be
cut down because of no removing
and reinstalling the part.

☆428-54-11371
(R.H)

To modify, do not remove
this part. If done so, the
working hours can be
cut down because of no
removing and reinstalling
the part.

☆428-54-11730

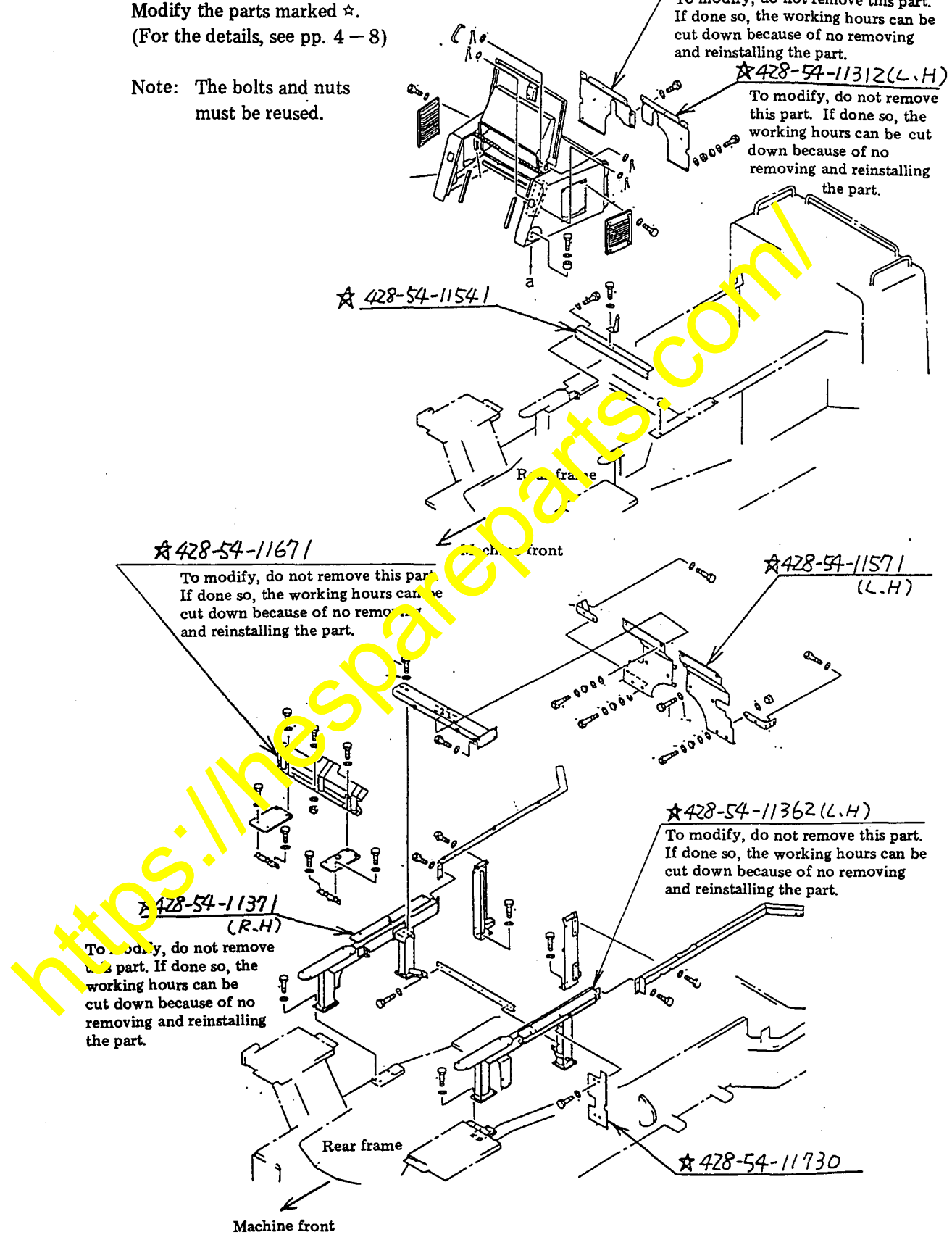

- 4-1 Modifying part 428-54-11322 (R.H)
Drill to make two $\phi 3$ mm holes in the positions as shown.

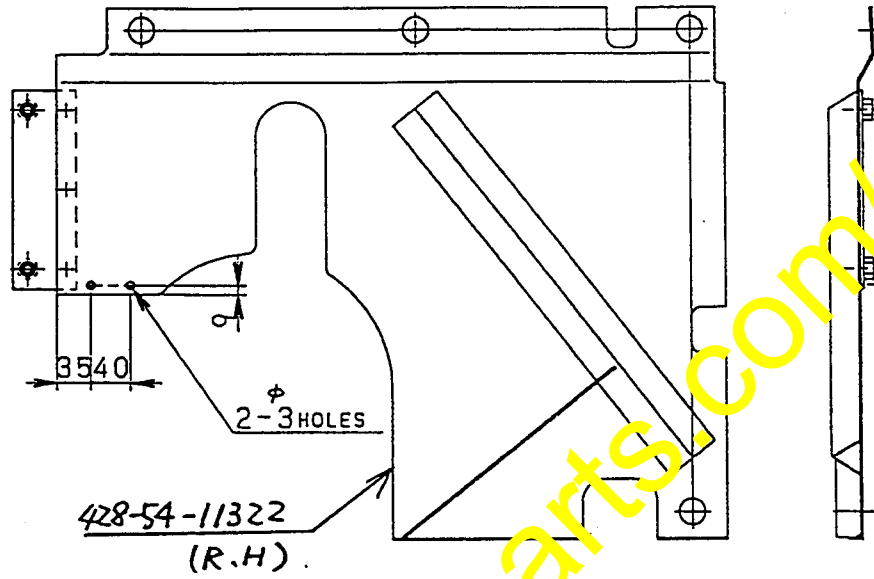

- 4-2 Modifying part 428-54-11312 (L.H)
Drill to make two $\phi 3$ mm holes in the positions as shown.

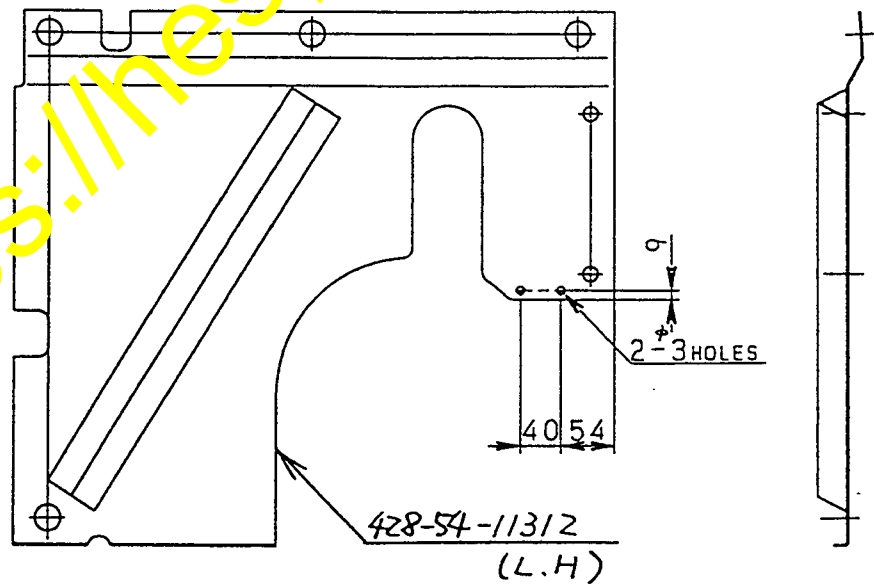

- 4-3 Modifying part 428-54-11730
 Drill to make seven $\phi 3$ mm holes
 in the position as shown.

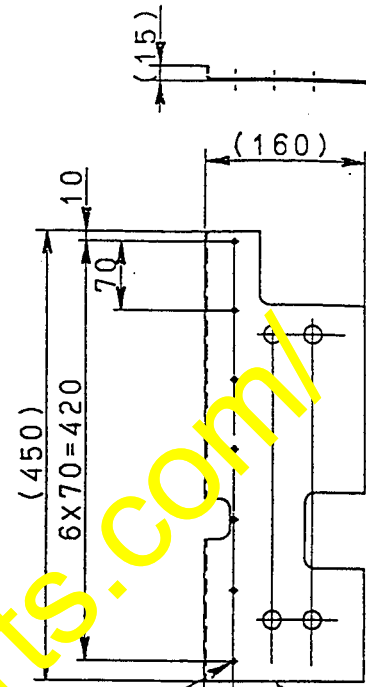

- 4-4 Modifying part 428-54-11571 (L.H)
 Drill to make eight $\phi 3$ mm holes
 in the position as shown.

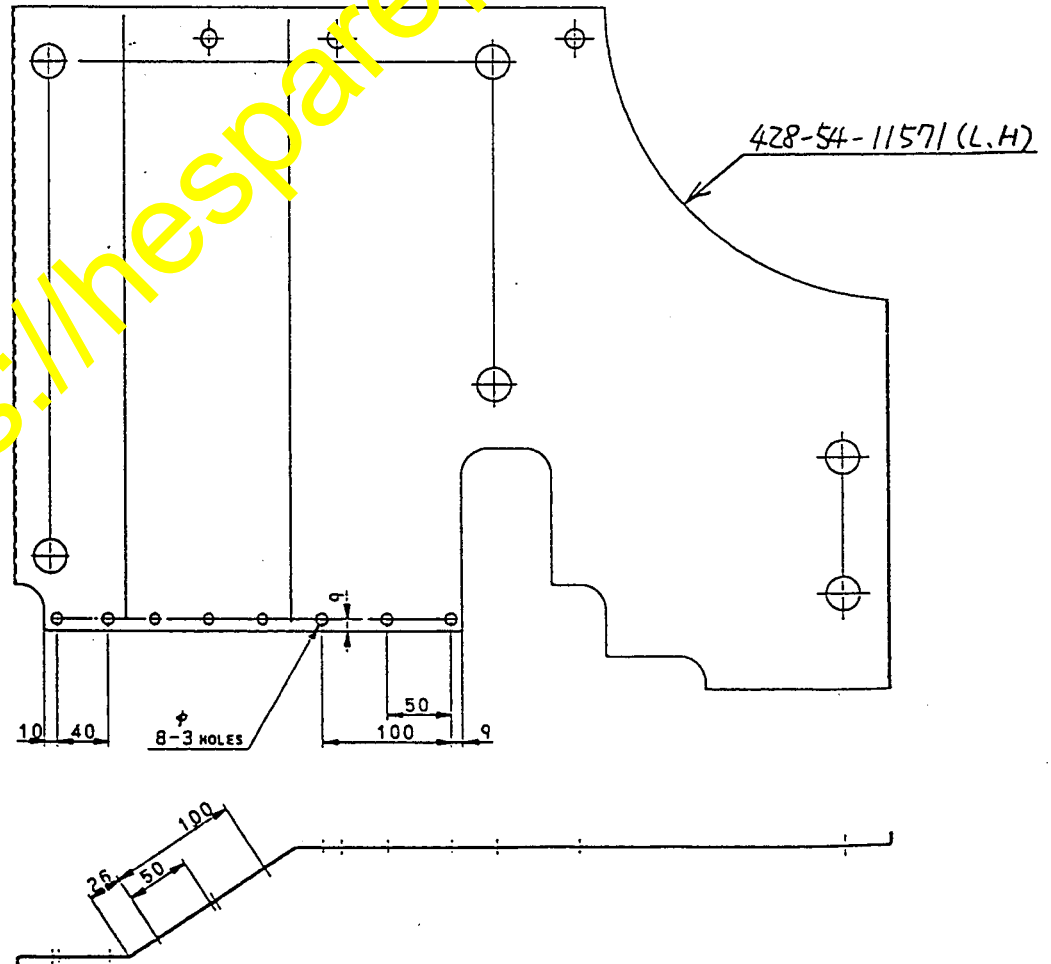

4-5 Modifying part 428-54-11671

Drill to make three $\phi 3$ mm holes in the positions as shown.

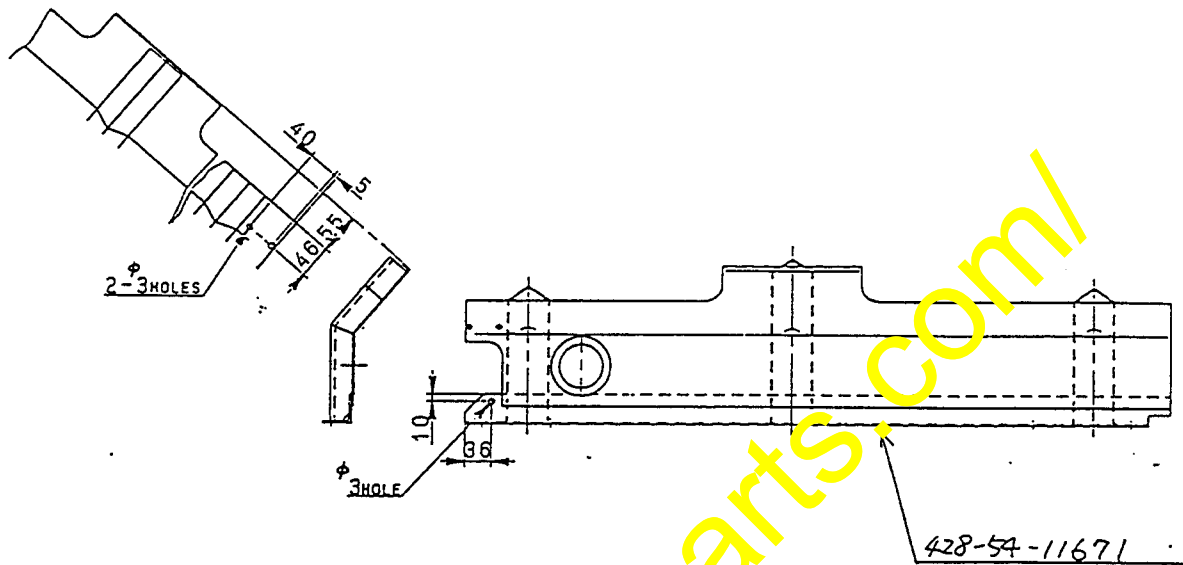

4-6 Modifying the bulkhead mounting bracket
Remove the sheet (only the one on the left-hand side), then weld the plate as shown below.

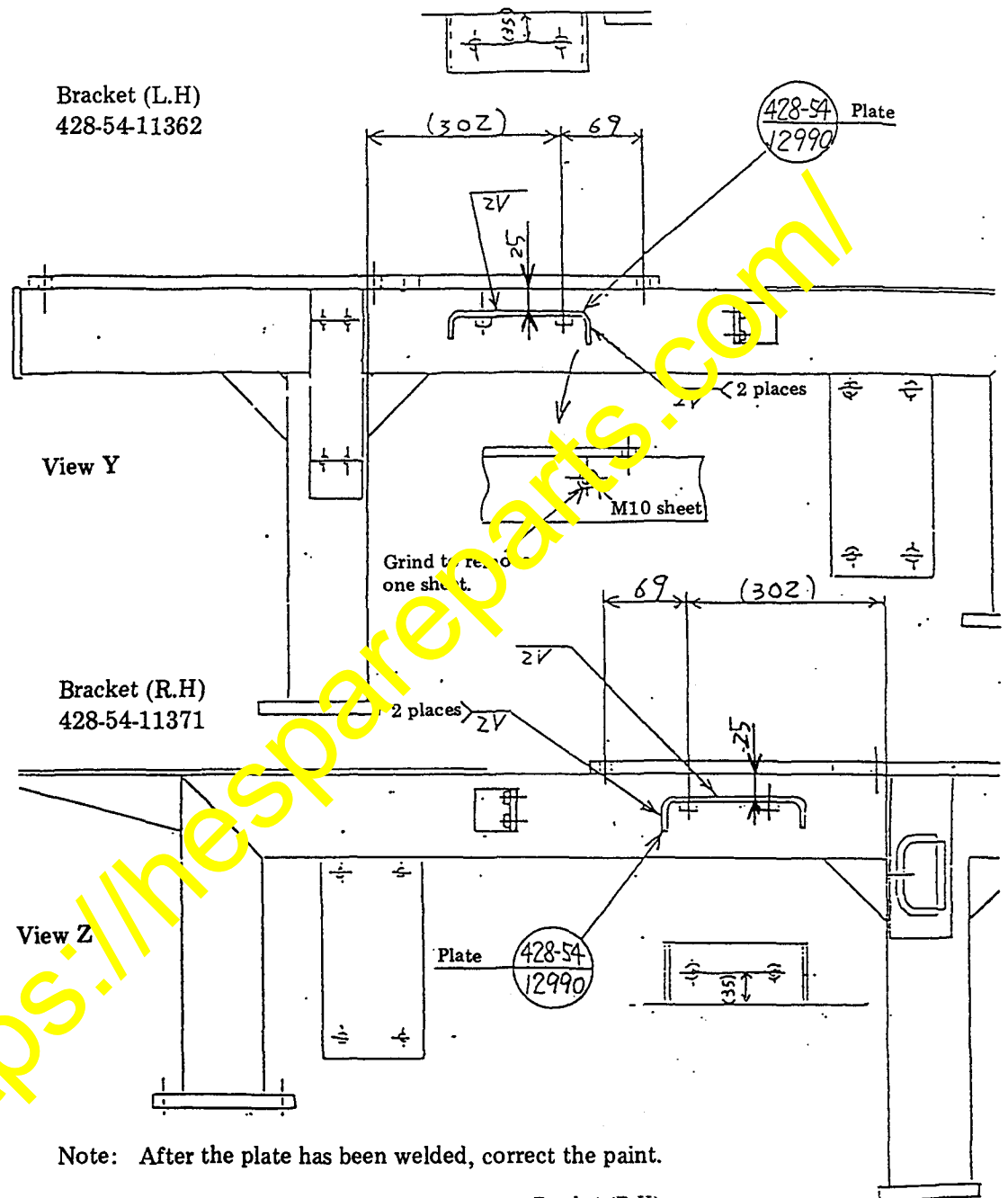

Note: After the plate has been welded, correct the paint.

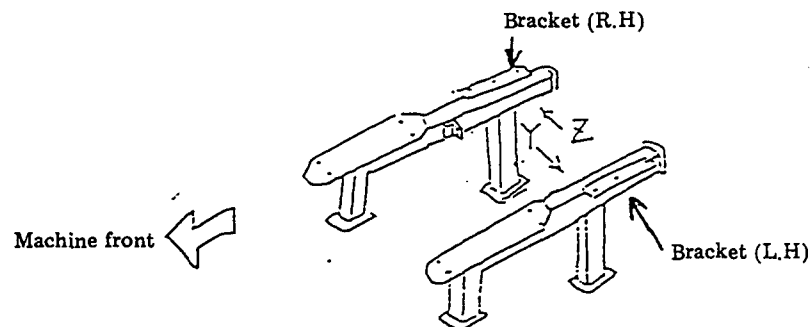

4-7 Modifying the angle

Weld plates (428-54-12960 and 428-54-12970) to the angle (428-54-11541), then drill to make two $\phi 3$ mm holes as shown. After the plates have been welded, correct the paint.

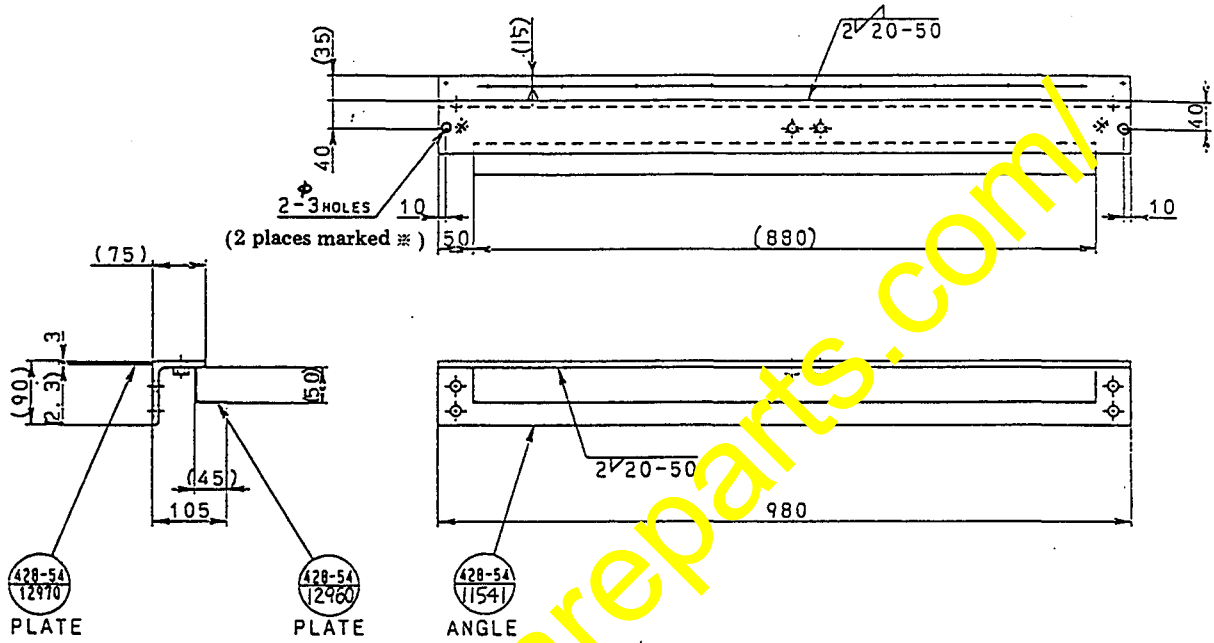

5. Assembling

5-1 Assembling the rubber parts on the partition plate
Assemble the rubber parts as shown below.

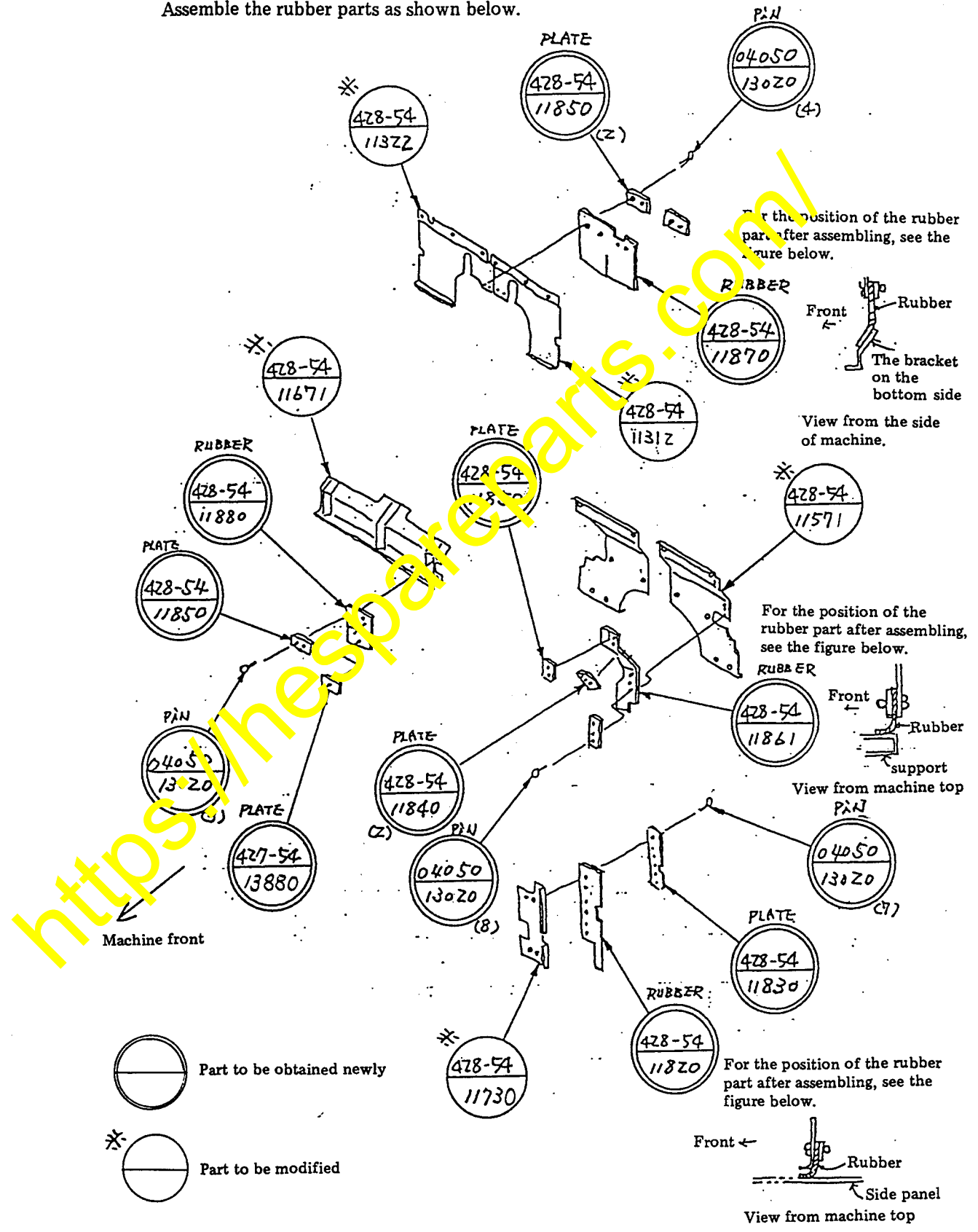

5-2 Assembling the added plates
Assemble the added plates as shown below.

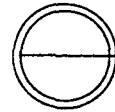
 : Part to be obtained newly

If the angle is found installed in the reverse position on top and bottom, reinstall it as shown.

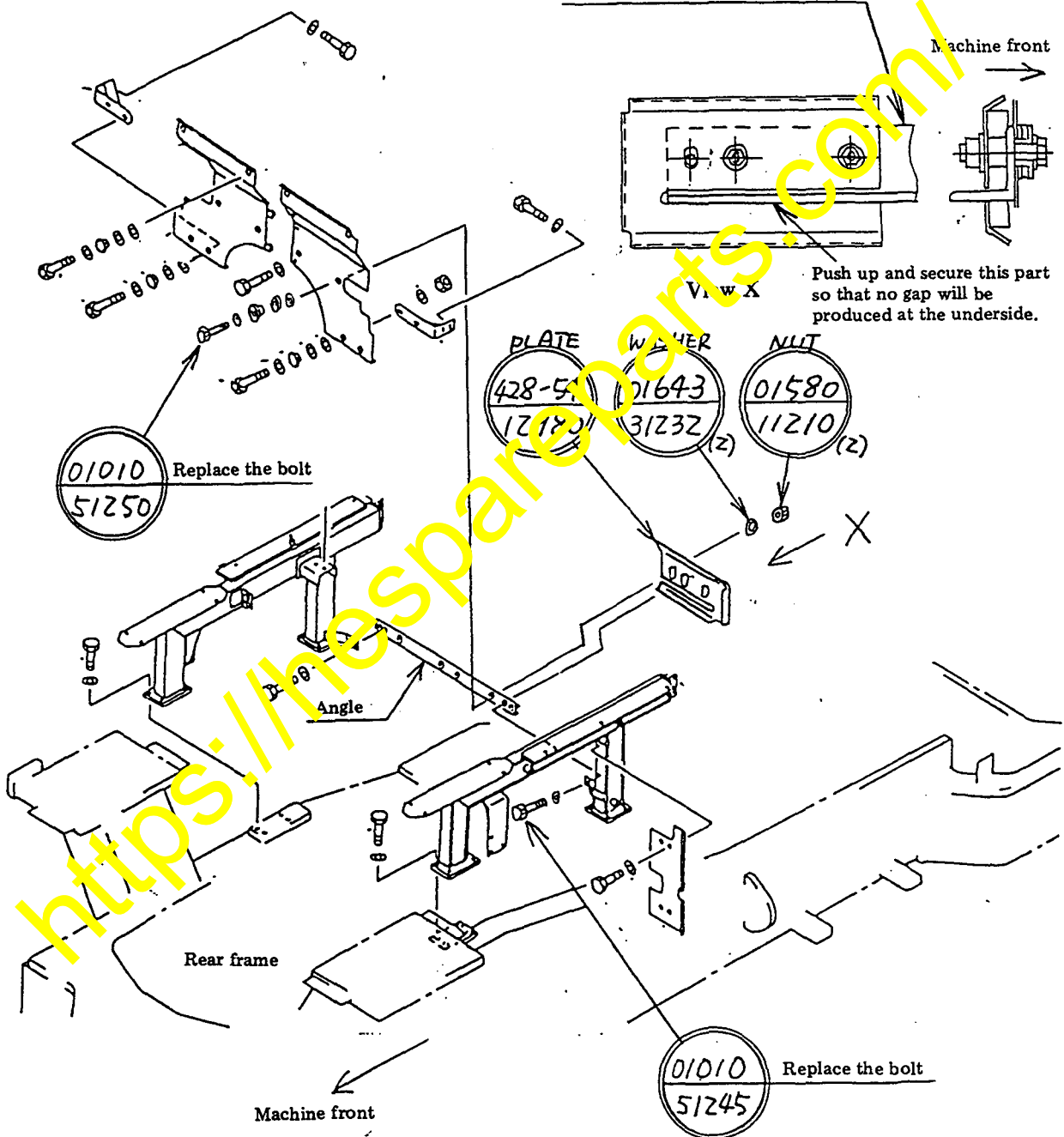

5-3 Assembling the partition plate to be added to the front of air cleaner (part 1)
Assemble the parts as shown.

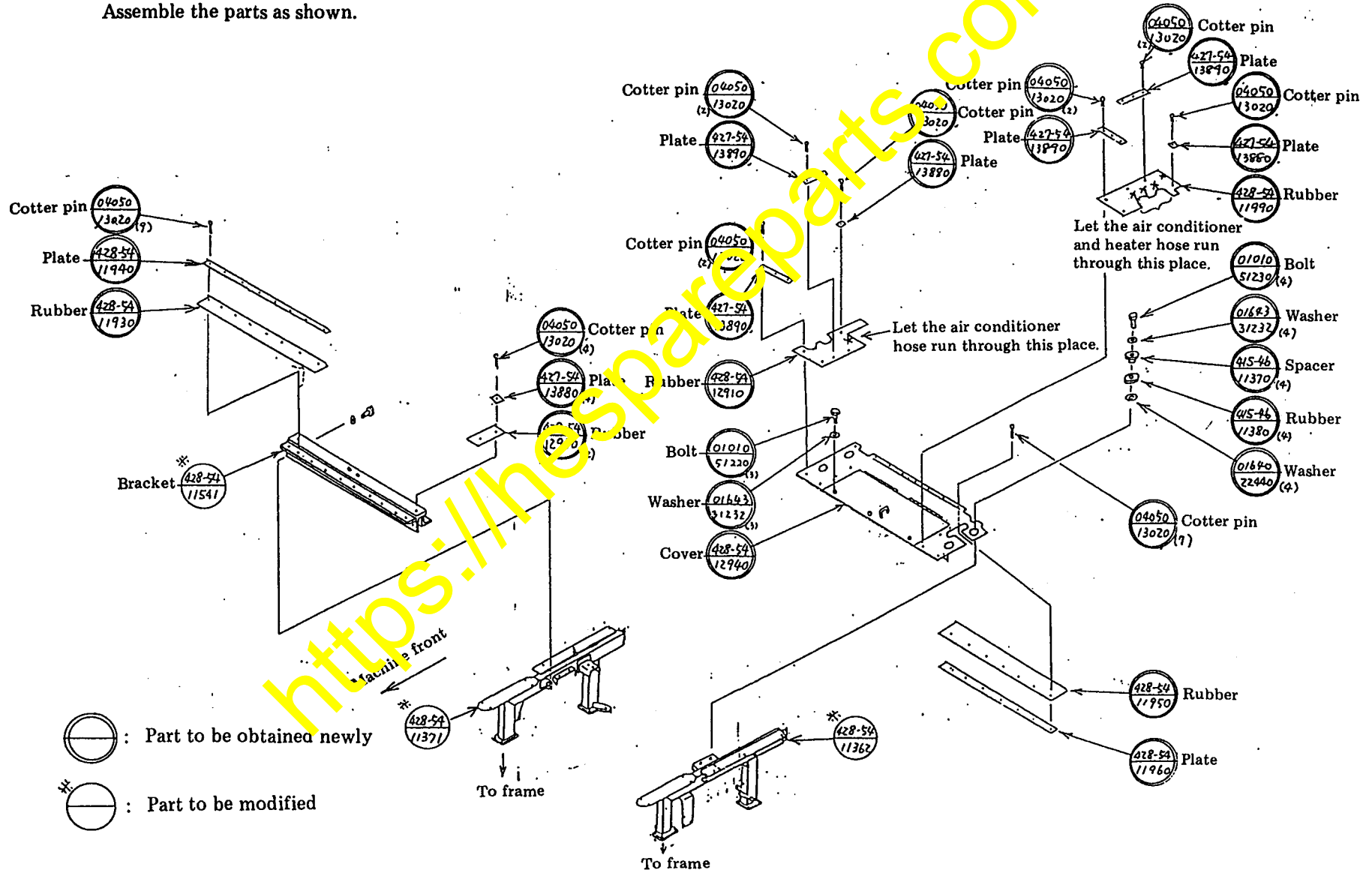

5-3 Assembling the partition plate to be added to the front of air cleaner (part 2)

Air conditioner tube section

Reinstall the clips (in 2 places) and also remove the clips (in 4 places) as shown below.

