

When replacing the mounting elbow, check and confirm the stamp reading "A" (1, Figure 2) provided on the side of the new elbow.

NOTE: WHILE REPLACING THE MOUNTING ELBOW, PRECAUTIONS MUST BE MADE NOT TO ALLOW DUST AND OTHER FOREIGN MATERIAL INTO THE HYDRAULIC CIRCUITS.

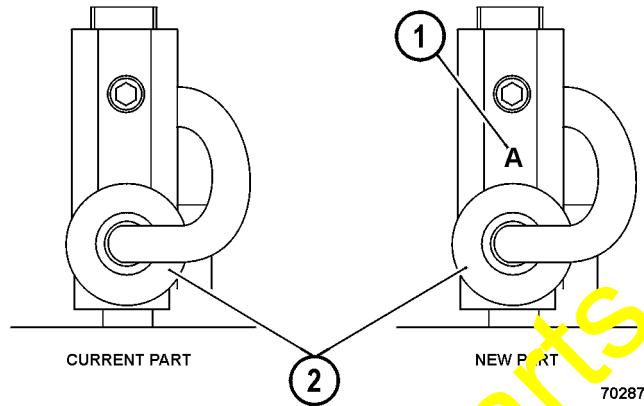

Figure 2. Identifying New And Current Parts

- 1. Identification Marking
- 2. Oil Pressure Sensor

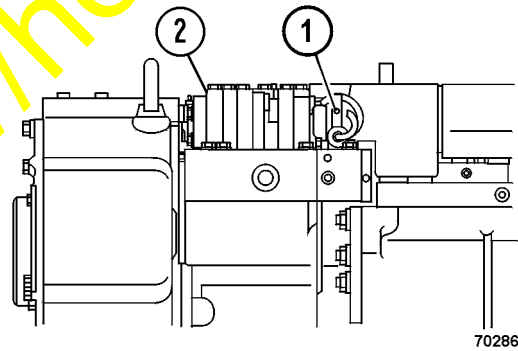

Figure 3. Installation of Mounting Elbow

- 1. Elbow
- 2. Valve Assembly

When replacing the mounting elbow, check and confirm the stamp reading "A" (1, Figure 2) provided on the side of the new elbow.

NOTE: WHILE REPLACING THE MOUNTING ELBOW, PRECAUTIONS MUST BE MADE NOT TO ALLOW DUST AND OTHER FOREIGN MATERIAL INTO THE HYDRAULIC CIRCUITS.

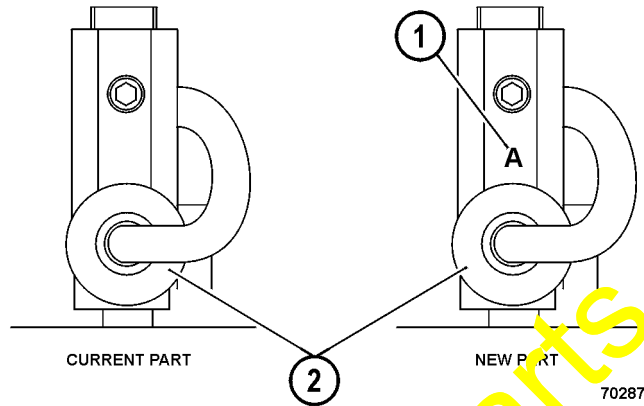

Figure 2. Identifying New And Current Parts

- 1. Identification Marking
- 2. Oil Pressure Sensor

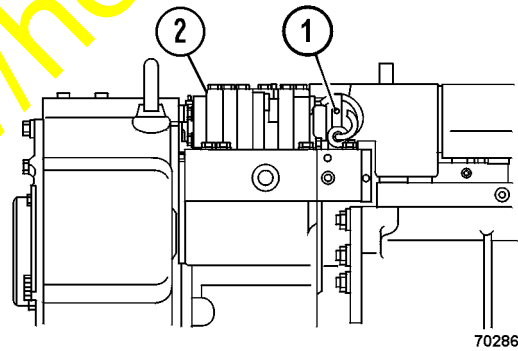

Figure 3. Installation of Mounting Elbow

- 1. Elbow
- 2. Valve Assembly

When replacing the mounting elbow, check and confirm the stamp reading "A" (1, Figure 2) provided on the side of the new elbow.

NOTE: WHILE REPLACING THE MOUNTING ELBOW, PRECAUTIONS MUST BE MADE NOT TO ALLOW DUST AND OTHER FOREIGN MATERIAL INTO THE HYDRAULIC CIRCUITS.

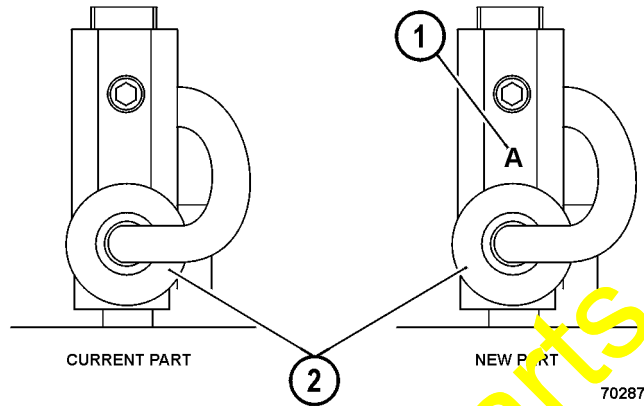

Figure 2. Identifying New And Current Parts

- 1. Identification Marking
- 2. Oil Pressure Sensor

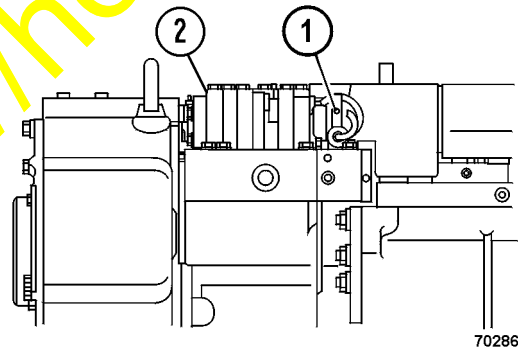

Figure 3. Installation of Mounting Elbow

- 1. Elbow
- 2. Valve Assembly

When replacing the mounting elbow, check and confirm the stamp reading "A" (1, Figure 2) provided on the side of the new elbow.

NOTE: WHILE REPLACING THE MOUNTING ELBOW, PRECAUTIONS MUST BE MADE NOT TO ALLOW DUST AND OTHER FOREIGN MATERIAL INTO THE HYDRAULIC CIRCUITS.

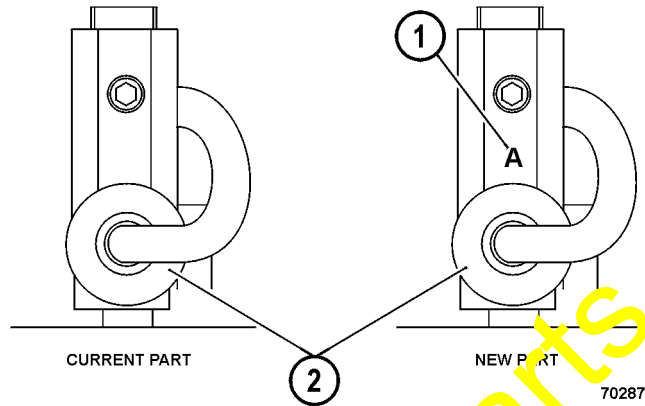

Figure 2. Identifying New And Current Parts

- 1. Identification Marking
- 2. Oil Pressure Sensor

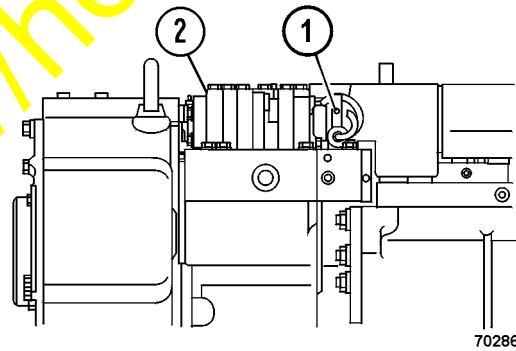

Figure 3. Installation of Mounting Elbow

- 1. Elbow
- 2. Valve Assembly

When replacing the mounting elbow, check and confirm the stamp reading "A" (1, Figure 2) provided on the side of the new elbow.

NOTE: WHILE REPLACING THE MOUNTING ELBOW, PRECAUTIONS MUST BE MADE NOT TO ALLOW DUST AND OTHER FOREIGN MATERIAL INTO THE HYDRAULIC CIRCUITS.

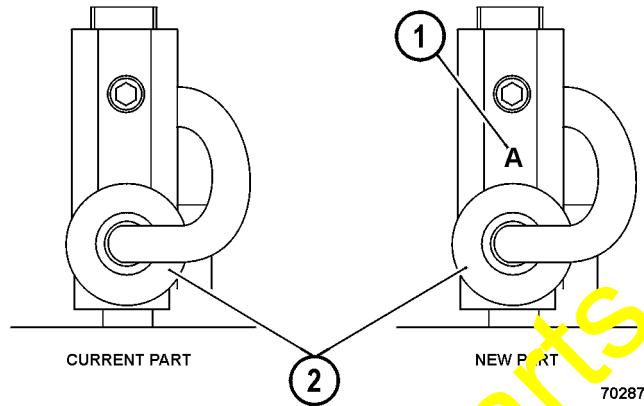

Figure 2. Identifying New And Current Parts

- 1. Identification Marking
- 2. Oil Pressure Sensor

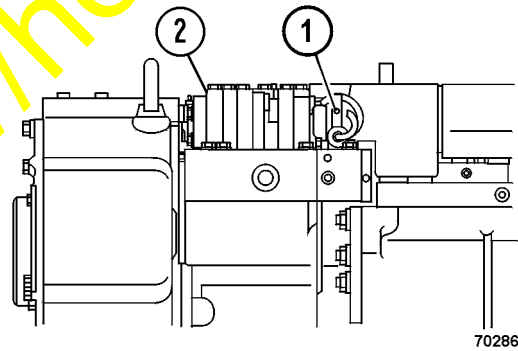

Figure 3. Installation of Mounting Elbow

- 1. Elbow
- 2. Valve Assembly