

# PARTS & SERVICE NEWS

REF NO. AA00141

DATE July 10, 2000

(C)

Page 1 of 5

**SUBJECT:** TROUBLESHOOTING OF CAB HARNESS

**PURPOSE:** To introduce how to troubleshoot cab harness

**APPLICATION:** HD785-3 Dump Trucks, S/N 2001 thru 2224  
HD785-5 Dump Trucks, S/N A10228 and up  
330M Dump Trucks, S/N Cf24120 and up

**FAILURE CODE:** D54099

**DESCRIPTION:**

Discontinuity of wiring harness may cause malfunctioning of all the circuits of electronic display panel.

This **PARTS & SERVICE NEWS** introduces the inspection and repair procedures for discontinuity of wiring harness together with examples of actual troubles.

List of supplied parts:

Number	Part No.	Part Name	Q'ty	Remarks
1	08018-00515	Sleeve	2	Wire Splicer
2	08033-10825	Tube	2	Heat Shrinkage

3. Inspection procedure

When monitor panel is totally inoperative, check the places of discontinuity by troubleshooting.

- \* Before carrying out troubleshooting, check that all the related connectors are properly inserted.
- ★ Always connect any disconnected connectors before going on to the next step.

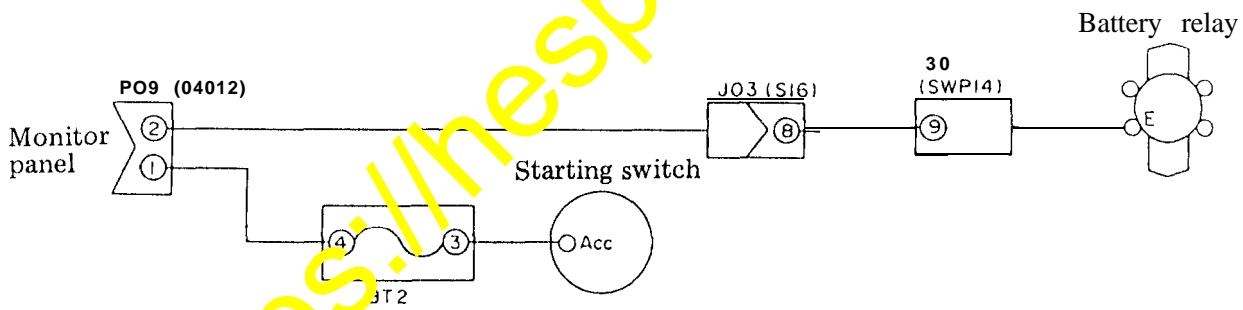
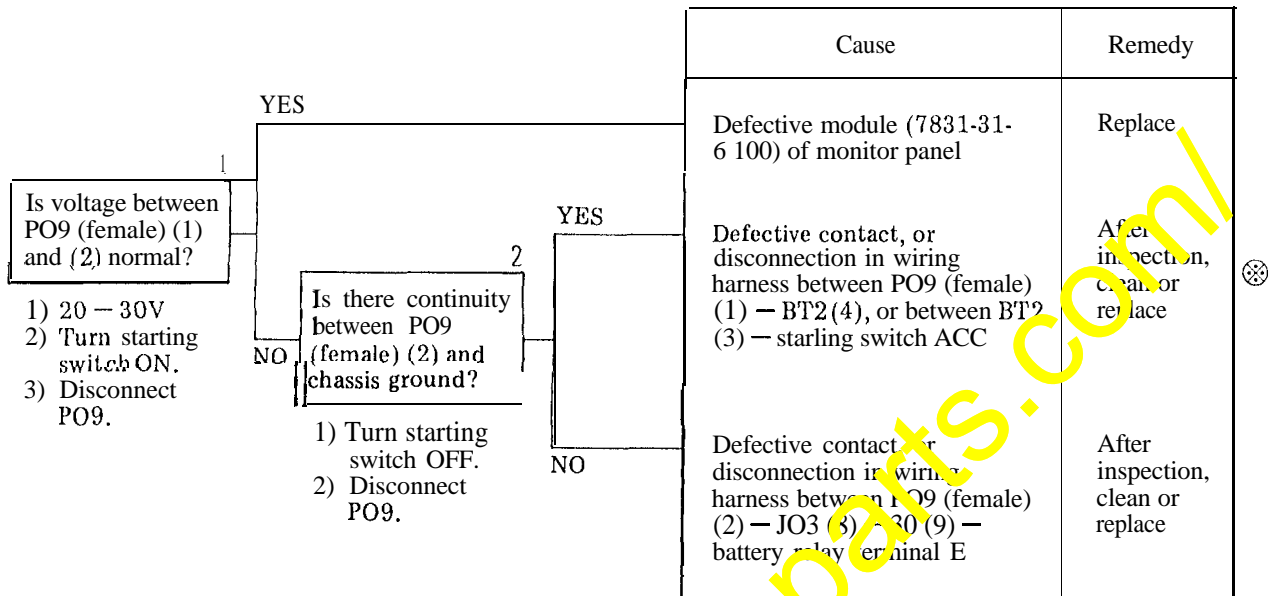

When the check resulted in ⊗, verify the discontinuity between PO9 ① and battery ④ using a tester.

By this check, estimate the discontinuity of wiring harness (561-06-63314) (For domestic) and wiring harness (561-87-61310) (For overseas).

## 4. Repair procedure

## (1) Verifying discontinuity

Discontinuity of wiring harness (561-06-63314) (For domestic), (561-87-61310) (For overseas) may be found at the branching connection of cables.

Remove floor cover (569-54-63430) of cab platform to pull out wiring harness. (Fig. 1)

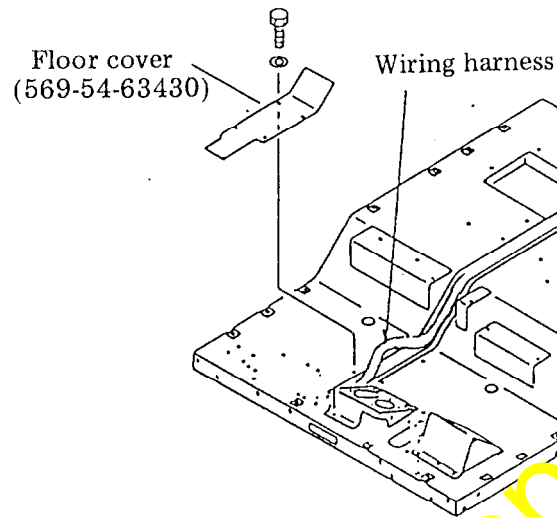

Fig. 1 Floor cover

(2) The cable branching connection of the applicable circuit is located at the middle of axle sensor harness and transmission lever harness, approx. 450 mm — 650 mm to the front of transmission lever harness.

Open harness conduit to pull out cable branching connection. (Fig. 2)

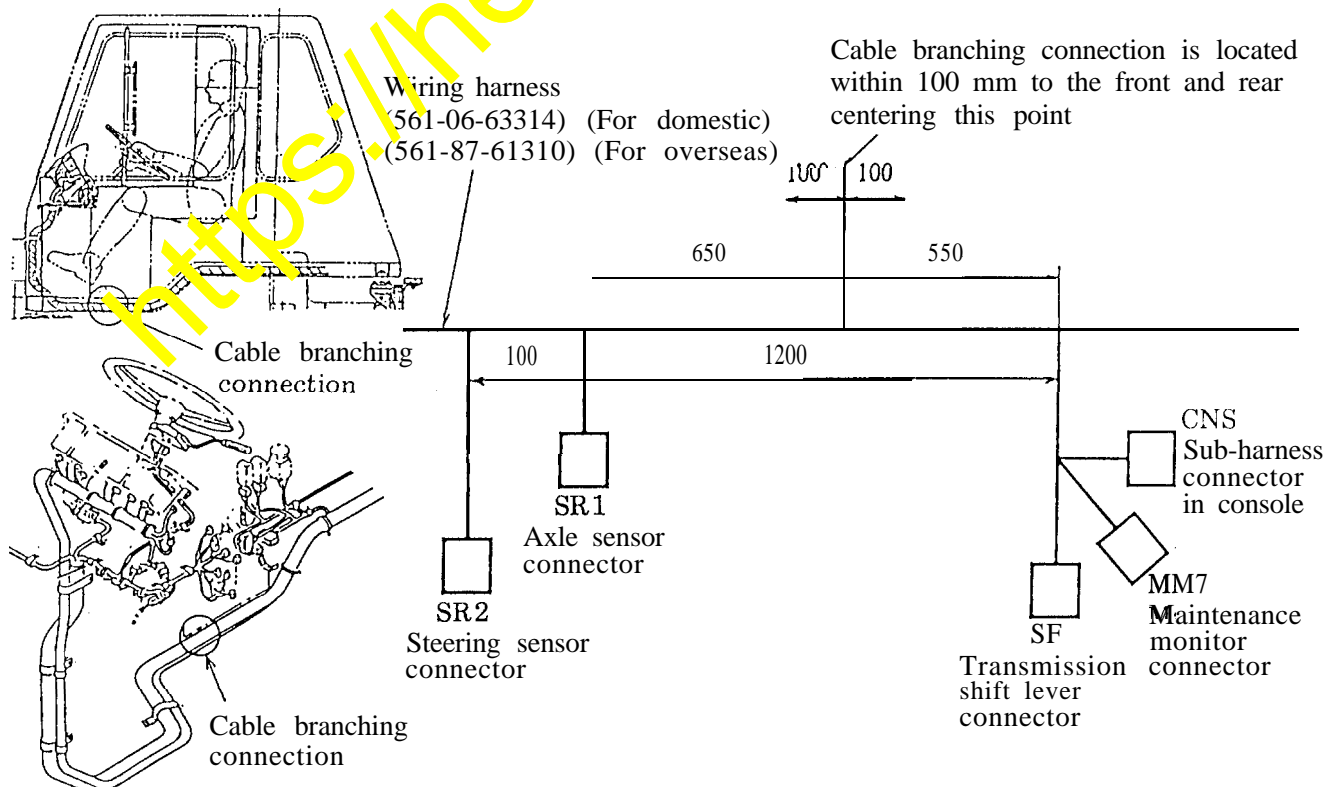

Fig. 2 Location of cable branching connection

- (3) Verify the discontinuity of cable branching connection.
- (4) Cut all the five wires at the points approx. 50 mm to the front and rear centering cable branching connection. (Fig. 3)

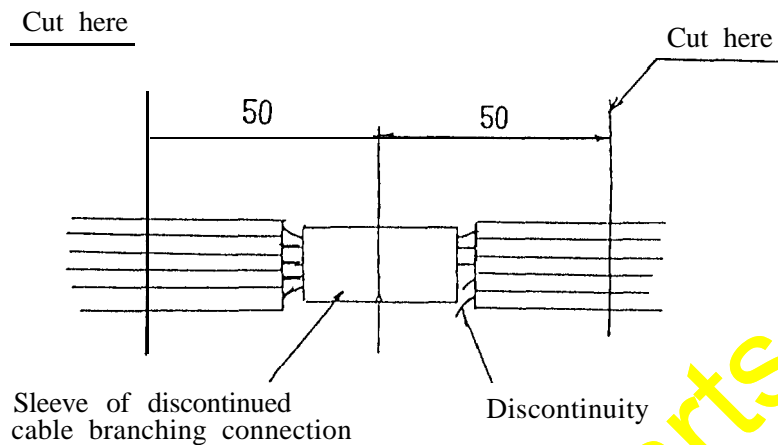

Fig. 3 Cutting of wire

- (5) Insert heat shrink tube (08033-10825) to each cut position.
- (6) Prepare 5 wires (KES 07.418.10.85) of 100 mm in length similar in size to that of cut wire.
- (7) Insert prepared wire and cut wire in wire splicer sleeve (08018-00515) to crimp using crimping tool. (Fig. 4)
- ★ Use YAT-1 (Dice AD-101) or equivalent by Nippon Crimping Terminal Co. recommended by KES 83.511 (Selection of wiring harness crimping tools) for crimping sleeve.

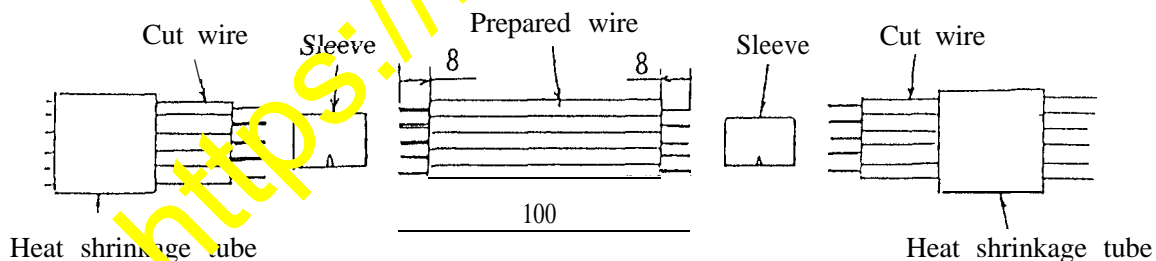

Fig. 4 Crimping of wire

- (8) Turn starting switch ON to verify the function of monitor panel.
- (9) Cover wire splicer sleeve (08018-00515) with inserted heat shrink tube (08033-10825) to heat shrink by the heat (90 – 115°C) of a drier or torch lamp.
- (10) Insert into original harness conduit to wrap it with tape and secure.
- (11) Clean storage groove to remove water before storing in cab floor.
- (12) Store wiring harness to install removed cover.

5. Precautions for cleaning cab inside

Water will not infiltrate into the applicable wiring harness which is located in cab floor by usual usage. But washing cab inside may cause splashing of water over wiring harness, entrapping water in the cable branching connection and resulting into discontinuity of cable through abrasion.

Observe the following when cleaning cab inside and pay attention water will not gather on the floor.

- (1) Wipe out dust without washing out cab floor.
- (2) Remove floor mats, wash with water in the outside and place on cab floor after drying thoroughly.

<https://hespareparts.com/>