

PARTS & SERVICE NEWS

| | |
|---------|---------------|
| REF NO. | AA00149 |
| DATE | July 24, 2000 |

Page 1 of 4

SUBJECT: REWIRE FUEL SHUT-OFF SWITCH

PURPOSE: To adjust connections of solenoid and add a fuse

APPLICATION: WA320-3MC Wheel Loader Serial Number A31303 and UP
WA380-3MC Wheel Loader Serial Number A51237 and UP
WA420-3MC Wheel Loader Serial Number A31075 and UP

FAILURE CODE: DW1381

DESCRIPTION:

Introduction:

This PARTS AND SERVICE NEWS rewires the fuel shut-off solenoid pull circuit. Originally wired to the starter solenoid, this switch is now connected to the starter's "M" terminal and an in-line fuse has been added. All wiring diagrams, Parts Books, and Service Manuals should be updated accordingly.

PARTS LIST

| Item | Part Number | Description | Qty | Remarks |
|------|--------------|------------------------|-----|--------------------------|
| 1 | - | Fuel Shut-off Solenoid | 1 | Shown for reference only |
| 2 | - | Starter Solenoid | 1 | Shown for reference only |
| 3 | - | Starter Motor | 1 | Shown for reference only |
| 4 | 08041-03000 | 30A Inline Fuse | 1 | Add |
| 5 | - | Engine Harness | 1 | Shown for reference only |
| 6 | 419-06-A1510 | Fuse Holder | 1 | Add |
| 7 | 08031-10210 | Terminal | 1 | Add |
| 8 | 08031-10206 | Terminal | 1 | Remove |

- The location of the starter:

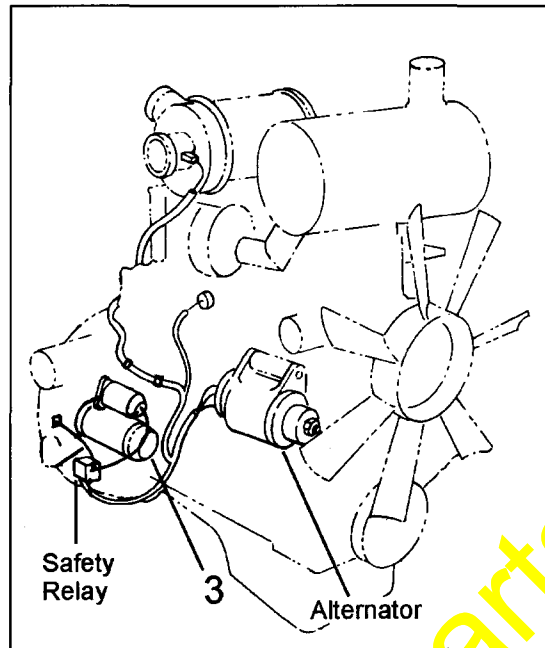

<https://hespareparts.com/>

- The old connections of the fuel shut-off solenoid:

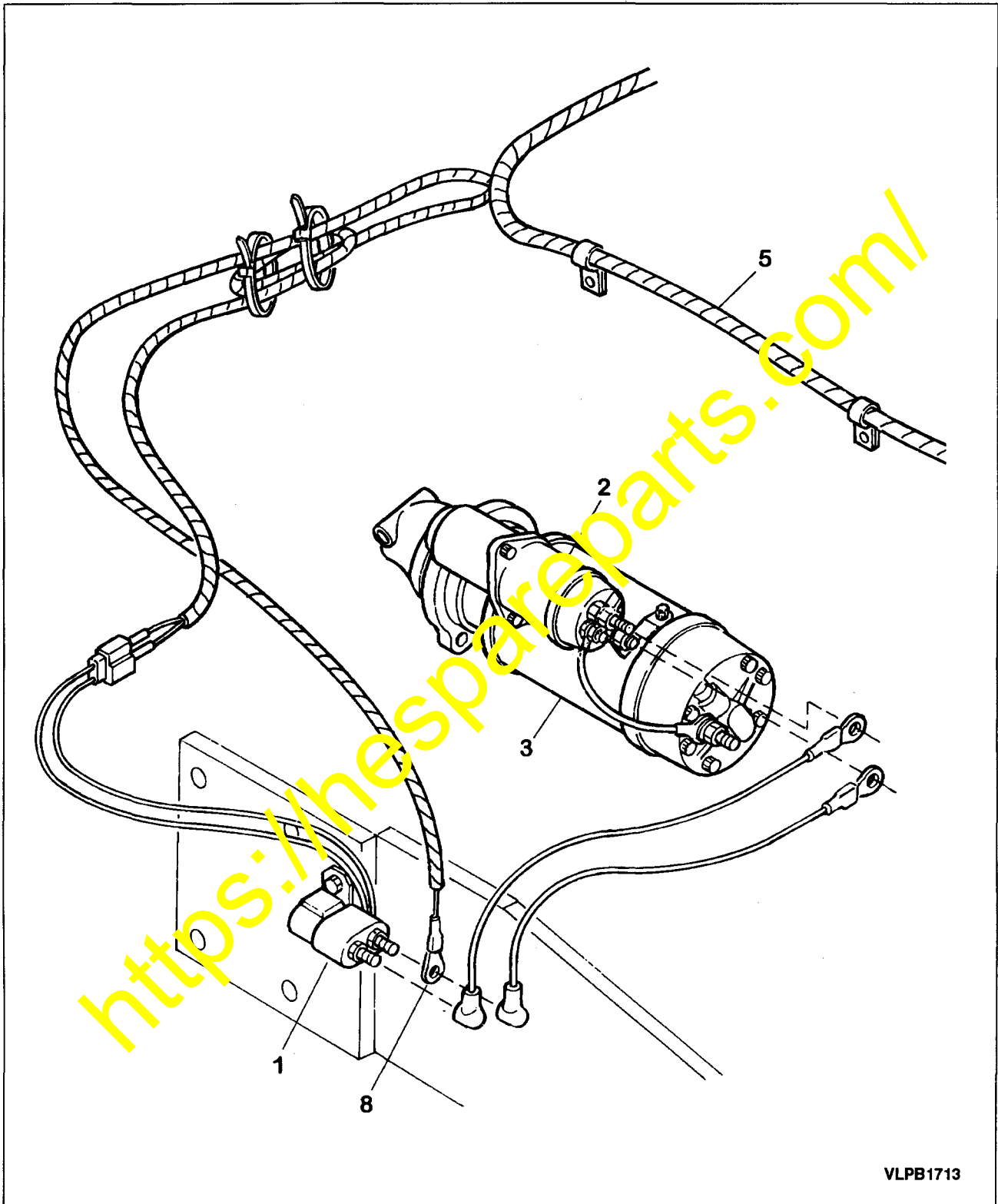

VLPB1713

- The new connections of the fuel shut-off solenoid:

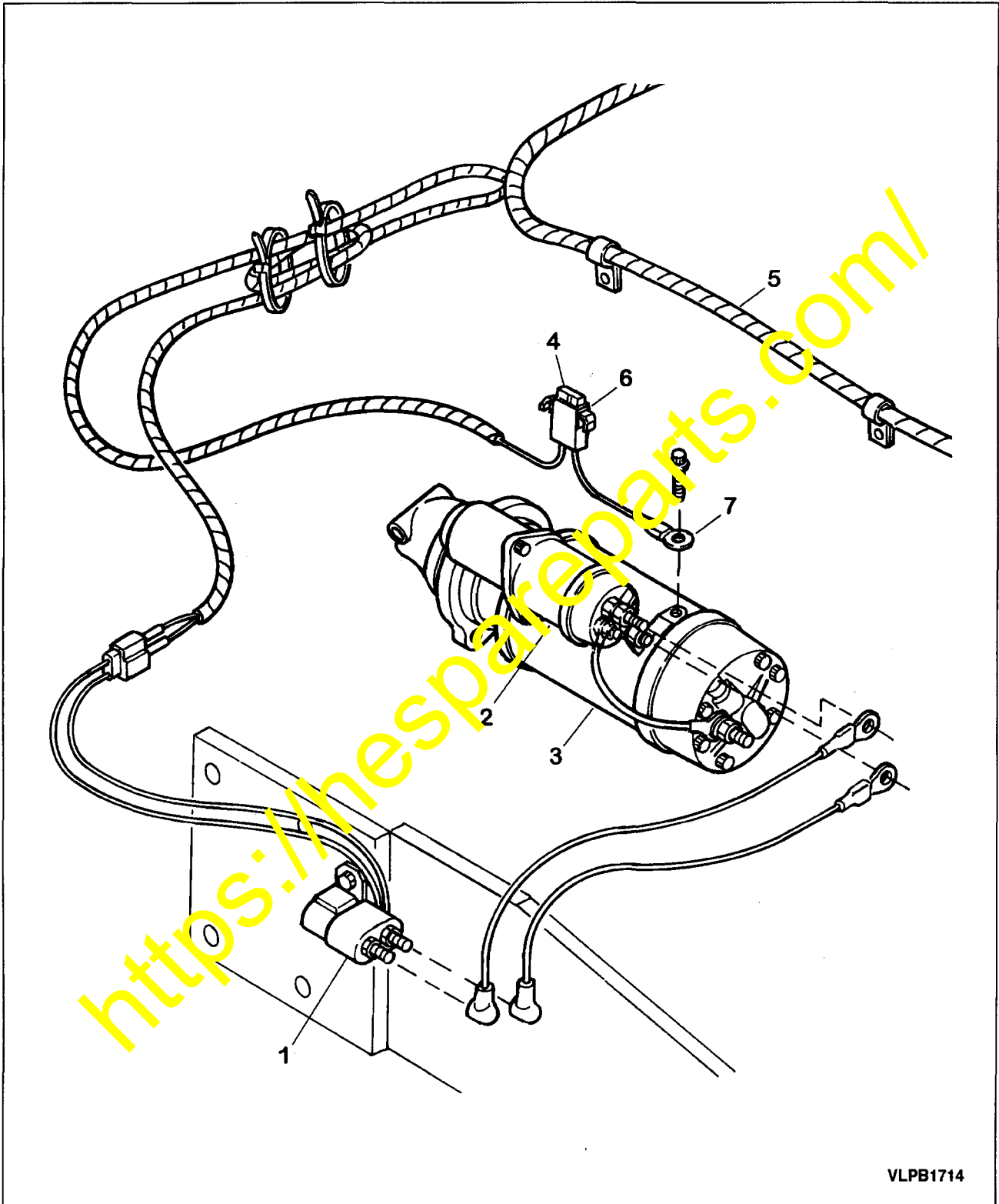

VLPB1714