

# PARTS & SERVICE NEWS

REF NO. AA01009

DATE January 10, 2001

Page 1 of 3

**SUBJECT:** MUFFLER TUBE REPLACEMENT

**PURPOSE:** To issue a repair procedure for the muffler tube which may have experienced cracking in the junction of the tube and muffler area.

**APPLICATION:** WA120-3L Wheel Loader Serial Number A30001 through A31000  
WA120-3MC Wheel Loader Serial Number A31001 through A31222

**FAILURE CODE:** 014137

**DESCRIPTION:**

Introduction:

This **PARTS AND SERVICE NEWS** will introduce a procedure for repairing the muffler tubes on the above machines.

PARTS LIST

Item	Part Number	Description	Qty	Remarks
1	416-02-A1132	Muffler	1	
2	416-02-A1151	Exhaust Bracket	1	
3	01010-80835	Bolt	1	
4	01643-31032	Washer	1	

Machine Preparation:

PLEASE OBSERVE ALL SAFETY AND PRECAUTIONARY STANDARDS AS DICTATED BY THE ENVIRONMENT AND WORK CONDITIONS UNDER WHICH THE EQUIPMENT WILL BE INSPECTED, REWORKED, OR REPAIRED. CONSULT THE "SHOP MANUAL", "OPERATOR'S AND MAINTENANCE MANUAL", OR YOUR "KOMATSU DISTRICT SERVICE MANAGER" WITH ANY/ALL QUESTIONS REGARDING SAFETY.

1. Park the wheel loader on a flat level surface. Lower the boom and bucket to the ground, shut off the engine and remove the key. Exercise the equipment controls to eliminate pressure locked in the system.

**IMPORTANT:** Attach a tag to the controls stating "THIS MACHINE IS BEING SERVICED. DO NOT ATTEMPT TO START THIS MACHINE UNTIL THIS TAG IS REMOVED BY THE PERSON PERFORMING THE SERVICE".

Removal of Bracket and Muffler:

1. Engine hood and covers  
Refer to "REMOVAL OF ENGINE HOOD" in Shop Manual.
2. Exhaust muffler  
Remove turbo-charger shield (1) and loosen muffler clamp (2) at turbo-charger.

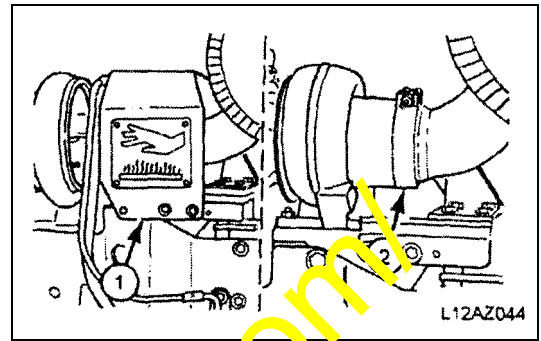

Remove band (3), remove center mounting bolts (4), and lift off exhaust muffler (5).

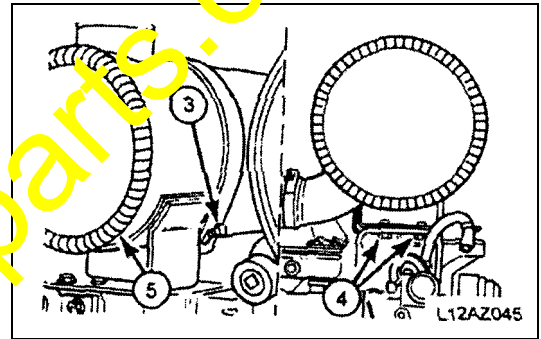

Remove bolt (3) and washer (4), remove exhaust bracket (2).

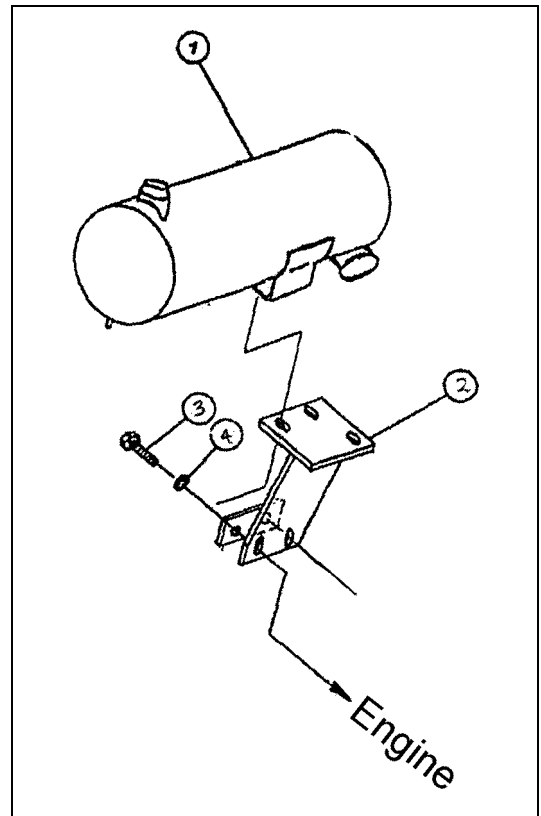

Installation of New Bracket and Muffler:

1. Install the new reinforced bracket (Item 2) and new muffler (Item 1) in reverse order of removal procedure.

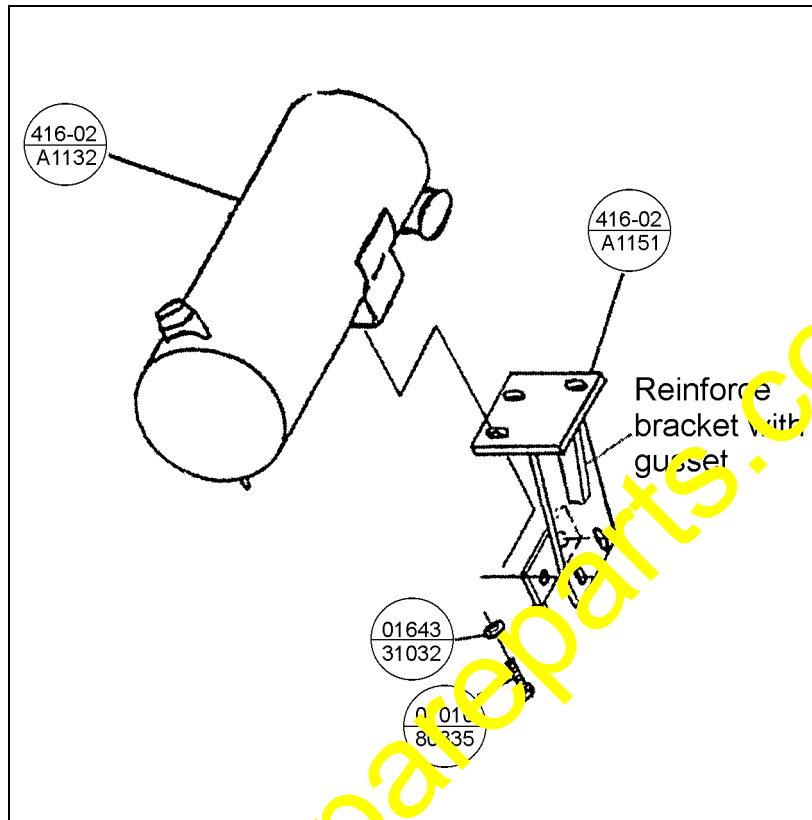

**NOTE:** An extra bolt and washer are required in the mounting of muffler to exhaust bracket.