

PARTS & SERVICE NEWS

REF NO.	AA01024
DATE	January, 12, 2001

SUBJECT: LEFT HAND MIRROR SHIMMING PROCEDURE

PURPOSE: To inform the field of shimming process for installation of left hand mirror assembly (PC0226).

APPLICATION: Komatsu Electric Drive Dump Trucks:
 730E: AFE47-V & up, A30079 & up;
 930E: AFE48-AQ & up, A30120 & up;
 Other dump trucks retrofitted with mirror assembly PC0226

FAILURE CODE: 5551EB

DESCRIPTION: This bulletin outlines a procedure to eliminate possible breakage of the left hand mirror due to distortion from excessive clearance between mating parts.

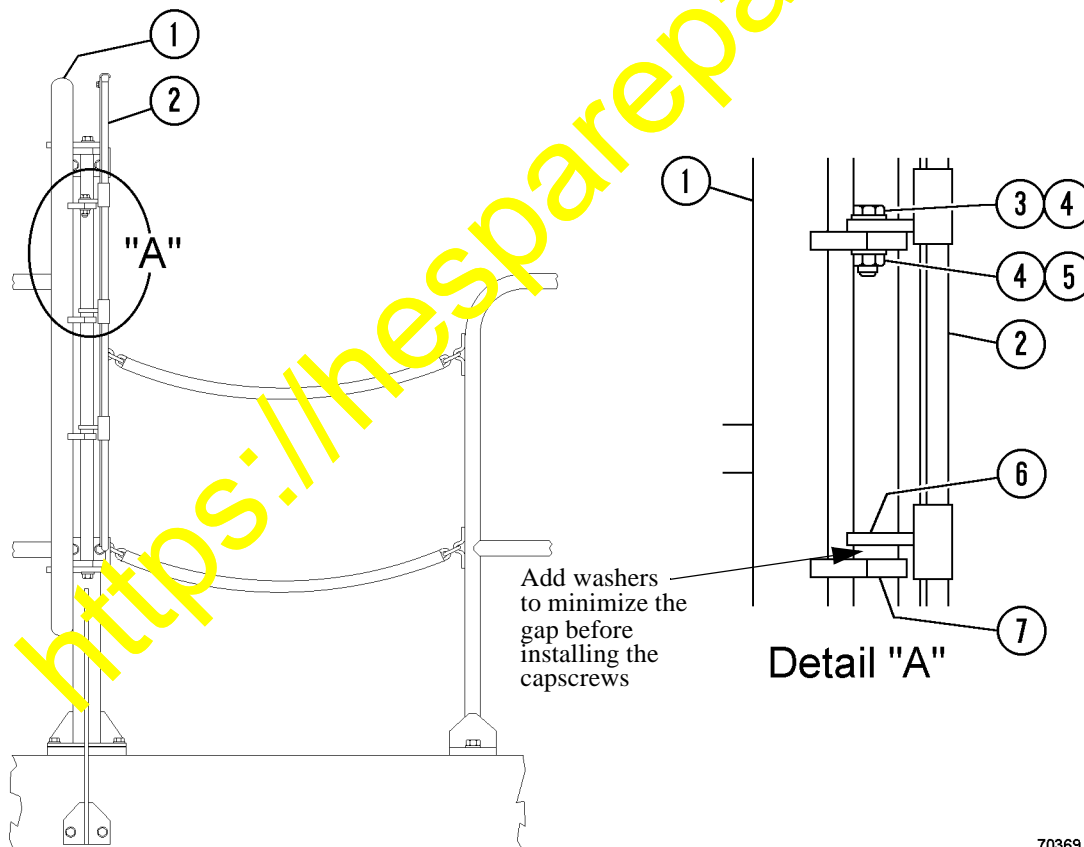

- 1. Mirror Mount
- 2. Mirror Assembly
- 3. Capscrew (MM0608)
- 4. Flat Washer (MM0461)

- 5. Lock Nut (MM0693)
- 6. Mounting Plate
- 7. Mounting Ear

70369

FIGURE 1. MIRROR MOUNTING ASSEMBLY

1. Set mirror (2) into position on mirror mount (1). Observe which mounting plates (6) on the mirror contact mounting ears (7) on the mirror mount. Install capscrew (3), two washers (4), and lock nut (5) to the mounting components that are in contact. A washer is to be installed between the head of the capscrew and mounting plate (6), and another washer between mounting ear (7) and the lock nut. Do not torque the capscrews at this time. (If a gap exists in between the other mounting components, do not install the capscrew to that portion of the mirror mount at this time.)
2. For the remaining mounting plates, install flat washers in between the mounting ears and the mounting plates in order to minimize the gap to within one flat washer. Refer to Figure 1. Install the capscrews, the washers, and the lock nuts. Each thread of the lock nuts must make full contact with the capscrews. Longer capscrews may be necessary. Tighten the capscrews to 10 ft.lbs. (14 Nm) torque.
3. After installation has been completed, check the mirror for tightness and for distortion. If the mirror is distorted, repeat this procedure or consult your local Komatsu dealer for further details.

<https://hespareparts.com/>

PARTS & SERVICE NEWS

REF NO.	AA01024
DATE	January, 12, 2001

SUBJECT: LEFT HAND MIRROR SHIMMING PROCEDURE

PURPOSE: To inform the field of shimming process for installation of left hand mirror assembly (PC0226).

APPLICATION: Komatsu Electric Drive Dump Trucks:
 730E: AFE47-V & up, A30079 & up;
 930E: AFE48-AQ & up, A30120 & up;
 Other dump trucks retrofitted with mirror assembly PC0226

FAILURE CODE: 5551EB

DESCRIPTION: This bulletin outlines a procedure to eliminate possible breakage of the left hand mirror due to distortion from excessive clearance between mating parts.

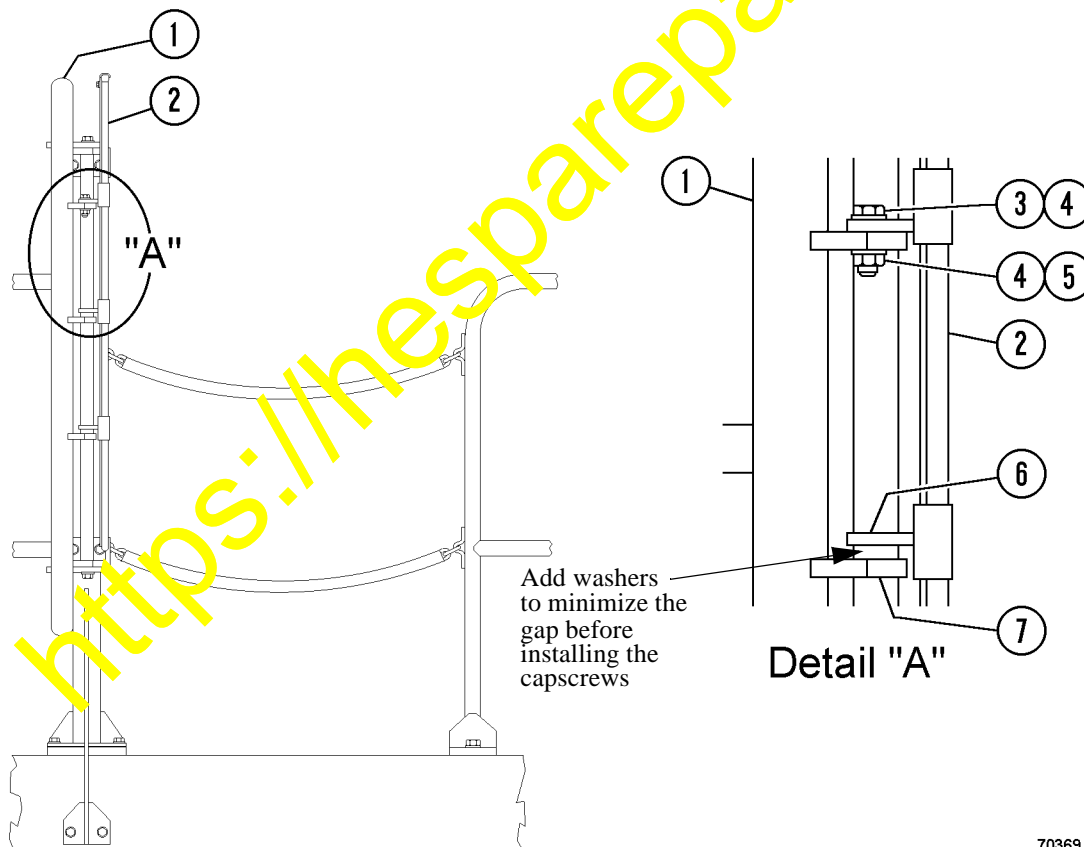

70369

- 1. Mirror Mount
- 2. Mirror Assembly
- 3. Capscrew (MM0608)
- 4. Flat Washer (MM0461)

- 5. Lock Nut (MM0693)
- 6. Mounting Plate
- 7. Mounting Ear

FIGURE 1. MIRROR MOUNTING ASSEMBLY

1. Set mirror (2) into position on mirror mount (1). Observe which mounting plates (6) on the mirror contact mounting ears (7) on the mirror mount. Install capscrew (3), two washers (4), and lock nut (5) to the mounting components that are in contact. A washer is to be installed between the head of the capscrew and mounting plate (6), and another washer between mounting ear (7) and the lock nut. Do not torque the capscrews at this time. (If a gap exists in between the other mounting components, do not install the capscrew to that portion of the mirror mount at this time.)
2. For the remaining mounting plates, install flat washers in between the mounting ears and the mounting plates in order to minimize the gap to within one flat washer. Refer to Figure 1. Install the capscrews, the washers, and the lock nuts. Each thread of the lock nuts must make full contact with the capscrews. Longer capscrews may be necessary. Tighten the capscrews to 10 ft.lbs. (14 Nm) torque.
3. After installation has been completed, check the mirror for tightness and for distortion. If the mirror is distorted, repeat this procedure or consult your local Komatsu dealer for further details.

<https://hespareparts.com/>