

# PARTS & SERVICE NEWS

REF NO. AA01073

DATE April 9, 2001

Page 1 of 2

- SUBJECT:** CRACKS IN 930E-1 FRONT WHEEL HUBS (EG7682) FOR 57 INCH TIRES AND RIMS
- PURPOSE:** To inform the field of possible modifications or replacements needed in the 930E-1 wheel hubs.
- APPLICATION:** Komatsu 930E Dump Trucks A30002 - A30097, A30099, A30101 - A30120
- FAILURE CODE:** 2A80HA
- DESCRIPTION:** Modification or replacement of cracked front wheel hubs (EG7682).

Cracks have been reported in the ribs of some front wheel hubs (EG7682). This problem has not occurred on 930E-2 wheel hubs which uses a ribless design. Depending on the number of ribs that are cracked and on the depth of the cracks, it may be possible to repair a front wheel hub.

A front wheel hub must be replaced if any of the following conditions are true:

1. A crack in a rib is more than 1.0 inch (25.4 mm) deep.
2. Cracks are found in four or more ribs.
3. A crack is found in a location other than a rib.

If cracks are found in fewer than four ribs, it may be possible to remove the cracks by grinding or by other mechanical means. No thermal process such as arc welding or torch cutting is permissible. It is permissible to remove a crack up to, but not exceeding 0.5 inch (12.7 mm) in depth by mechanical means. The crack may be ground out of the rib, thereby removing up to 0.5 inch (12.7 mm) of the rib.

*Note: It is not necessary to remove material from any ribs without cracks in order to have all ribs the same dimensions.*

Cracks that are deeper than 0.5 inch (12.7 mm) may not be repaired. If a crack increases to 1.0 inch (25.4 mm) in depth, the hub must be replaced. For further grinding instructions, refer to Figure 1.

**▲ CAUTION**

*If cracks are removed by grinding, the direction of grinding should be radial, along the length of the rib, and must not be transverse, across the rib.*

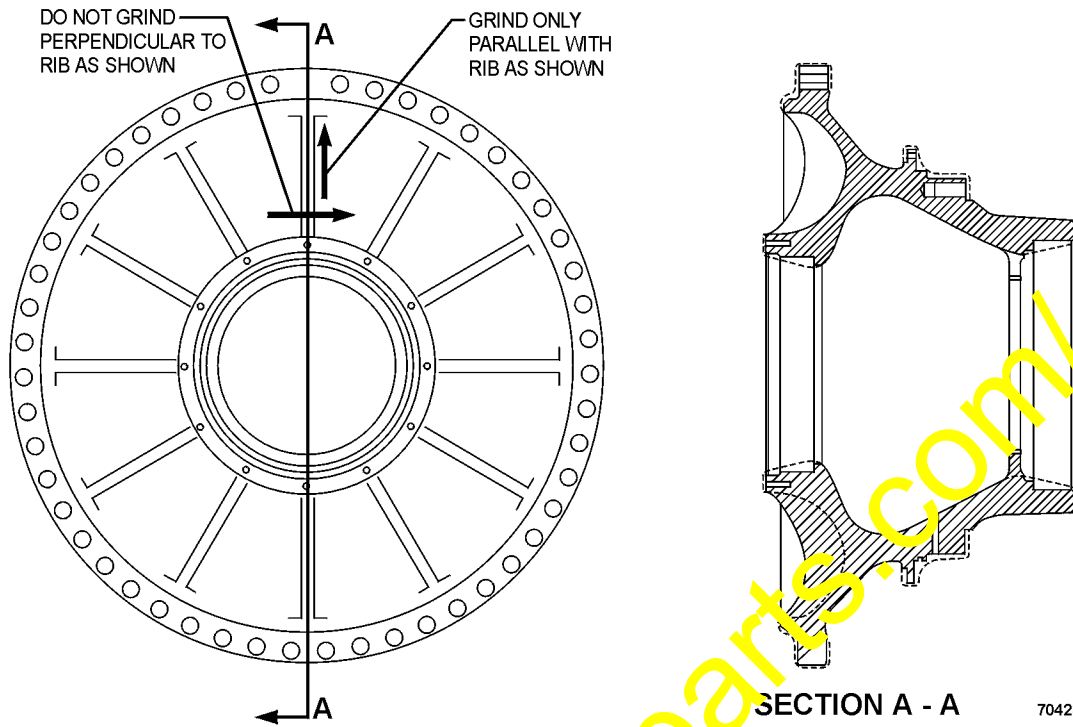

FIGURE 1. FRONT WHEEL HUB

<https://hespareparts.com/>