

# PARTS & SERVICE NEWS

REF NO.	AA01136
DATE	June 29, 2001

(C)

Page 1 of 4

**SUBJECT:** INTRODUCTION OF MASKING SEAL FOR TRANSMISSION ECMV

**PURPOSE:** To introduce the masking seal

**APPLICATION:** HD255-5 Dump Truck, S/N 1001 and up  
 HD325-6 Dump Truck, S/N 5001 and up  
 HD325-6A Dump Truck, S/N 5001 and up  
 HD405-6 Dump Truck, S/N 1001 and up  
 HD605-5 Dump Truck, S/N 1001 and up  
 HD785-3 Dump Truck, S/N A3001 and up  
 HD785-3 Dump Truck, S/N 2001 and up  
 HD785-3 Dump Truck, S/N 3001 and up  
 HD785-5 Dump Truck, S/N 4001 and up  
 HD785-5LC Dump Truck, S/N A10001 and up  
 HD985-3 Dump Truck, S/N 1001 and up  
 HD985-5 Dump Truck, S/N 1021 and up  
 HD1500 Dump Truck, S/N A30039 and up  
 330M Dump Truck, S/N BFP41A and up  
 330M Dump Truck, S/N BFP42A and up  
 330M Dump Truck, S/N A10120 thru A10227  
 530M Dump Truck, S/N A30031 thru A30038  
 GD555-3 Motor Grader, S/N 50001 and up  
 GD655-3C Motor Grader, S/N 50001 and up  
 GD675-3C Motor Grader, S/N 50001 and up  
 WA500-3 Wheel Loaders, S/N 50001 and up  
 WA500-3L Wheel Loaders, S/N A70001 and up  
 WA500-3LX Wheel Loaders, S/N A71001 and up  
 D375A-3 Crawler Loader, S/N 17001 and up  
 D575AR-2 Crawler Loader, S/N 10001 and up  
 MS1502-11 All Serial Numbers  
 HV400AS-2 All Serial Numbers  
 PW128UU-1 All Serial Numbers

**FAILURE CODE:** 15S0BP

**DESCRIPTION:**

This **PARTS & SERVICE NEWS** will introduce the masking seal newly prepared for use to cover the surface that the ECMV's are removed from thereby preventing entry of dust through the holes during the disassembly work of a transmission assembly.

2. Contents of modification

When the ECMV has been removed, apply the following masking seal so as to cover all the oil holes in the bared section of the valve seat where the ECMV was mounted.

(Modification procedure)

- 1) Remove the ECMV and O-rings.
  - 2) Softly wipe out the ECMV mounting portion (valve seat) with clean waste cloth.
  - 3) Remove the masking seal from the back-up paper and apply it so that all the oil holes will be blinded.
- (Use one sheet of masking seal per ECMV.)
- 4) Repair ECMV.
  - 5) Peel off the masking seal from the valve seat.
  - 6) Mount O-rings (new parts).
  - 7) Re-mount ECMV.

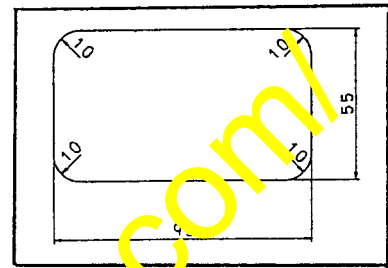

Masking seal shape  
(561-15-55990): Spare part number

<Example of repairing REV ECMV for the HD785-5>

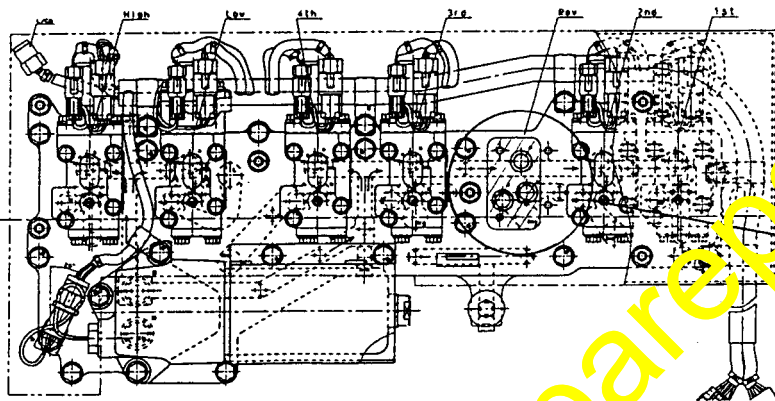

ECMV : 561-15-55400 (L)  
561-15-00863 (H, R, 1st - 4th)

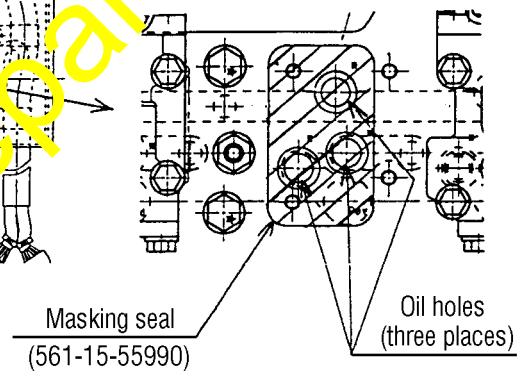

<Example of repairing FH ECMV for the GD655-3C, GD555-3C and GD675-3C>

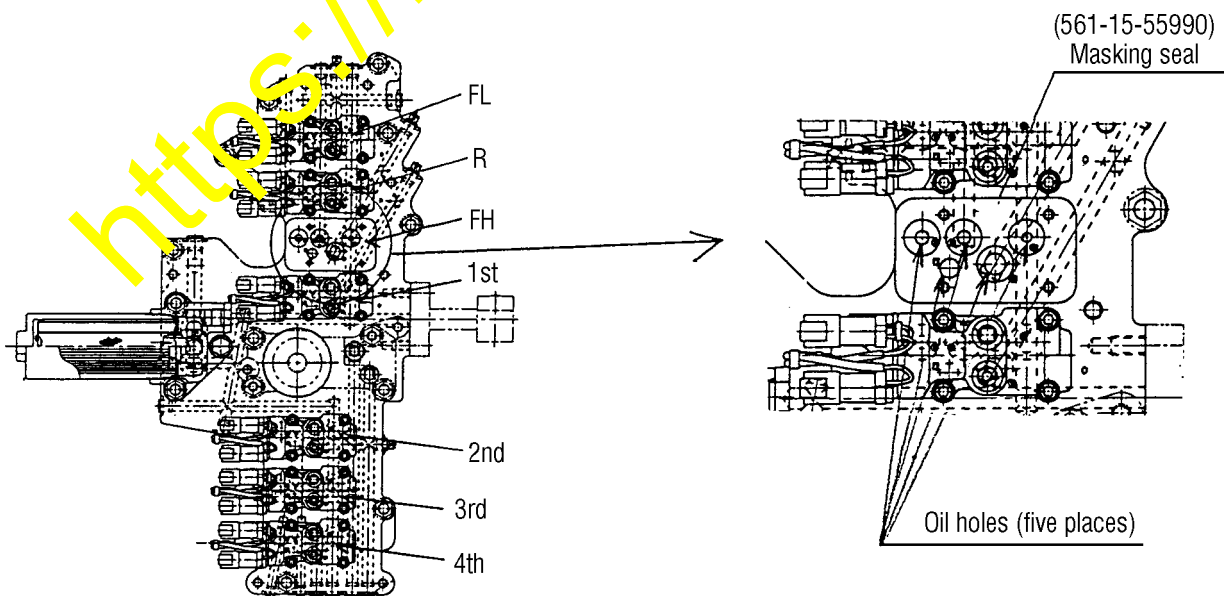

ECMV : 714-23-15500 (FL, FH, R, 1st - 4th, L/C)

<Example of repairing R ECMV for the HD255-5>

When repairing this valve, two types of seats, that is, "561-15-55990" shown on page 2 and "712-85-16310" (see the following drawings) can be used.

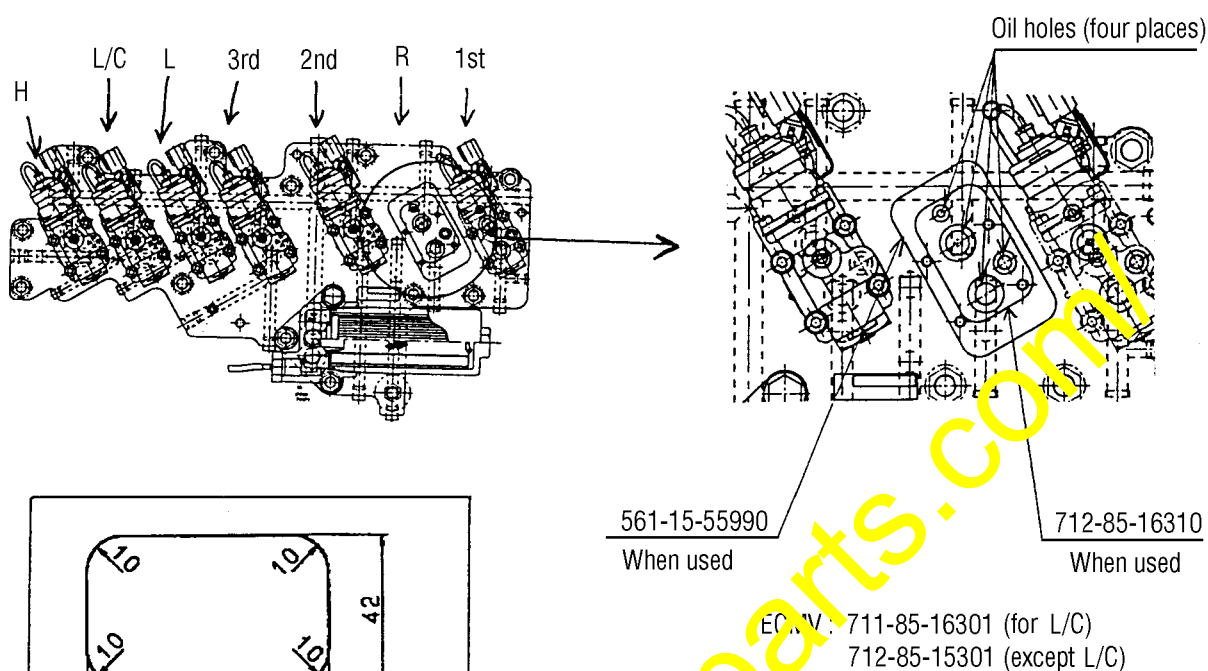

(Relationship between the masking seal and ECMV)

No.	Model	ECMV part number	Masking seal part number
1	HD225-6, HD325-6 4WD	561-15-55400	561-15-55990
	HD405-5, HD465-5, HD605-5, 330M		
	HD 85-3, HD785-5, HD985-3, HD985-5		
	HV700-2		
2	530M/HD1500	561-13-46802	
3	D375AR-2, HV700-2	561-15-00863	
4	D575AR-2	19M-15-15102	
5	GD655-3C, GD555-3C, GD675-3C	714-23-15500	
6	WA500-3	711-85-16101	561-15-55990
7	HD255-5, HS150S-11	711-85-16301	712-85-16310
8	HD255-5, HS150S-11, HU400AS-1	712-85-15301	
9	PW128UU-1	21J-15-15101	

3. List of parts

Part No.	Part Name	Q'ty	Remarks
561-15-55990	Sheet	1	} One sheet for each ECMV
712-85-16310	Sheet	1	

<https://hespareparts.com/>