

# PARTS & SERVICE NEWS

REF NO.	AA01142
DATE	July 10, 2001

Page 1 of 3

**SUBJECT:** REPAIR TO IMPROVE WATERPROOF-ABILITY OF T/M CONTROLLER MOUNTING SECTION

**PURPOSE:** To introduce modification procedures to improve the water proofing capability of the tranmission controller mount section. (Canopy or cab-less, Canopy-less with automatic shift transmission)

**APPLICATION:** WA250-3PT Wheel Loader Serial Number A75039 thru A75312  
WA250-3L Wheel Loader Serial Number A70112 thru A70432  
WA250-3MC Wheel Loader Serial Number A71007 thru A71331  
WA250PT-3MC Wheel Loader Serial Number A78027 thru A78067

**FAILURE CODE:** DA00PQ

**DESCRIPTION:**

The WA250-3 Wheel Loaders equipped with the open ROPS canopy and the auto-shift transmission have experienced controller failures due to water entering the controllers. This **Parts and Service News** introduces a countermeasure to prevent water intrusion of the transmission controller.

**LIST OF PARTS:**

Part No.	Part Name	Purpose of part	Q'ty	Remarks
417-54-A2160	Sheet-rubber	Additional	1	
418-54-A1170	Seal	Additional	1	

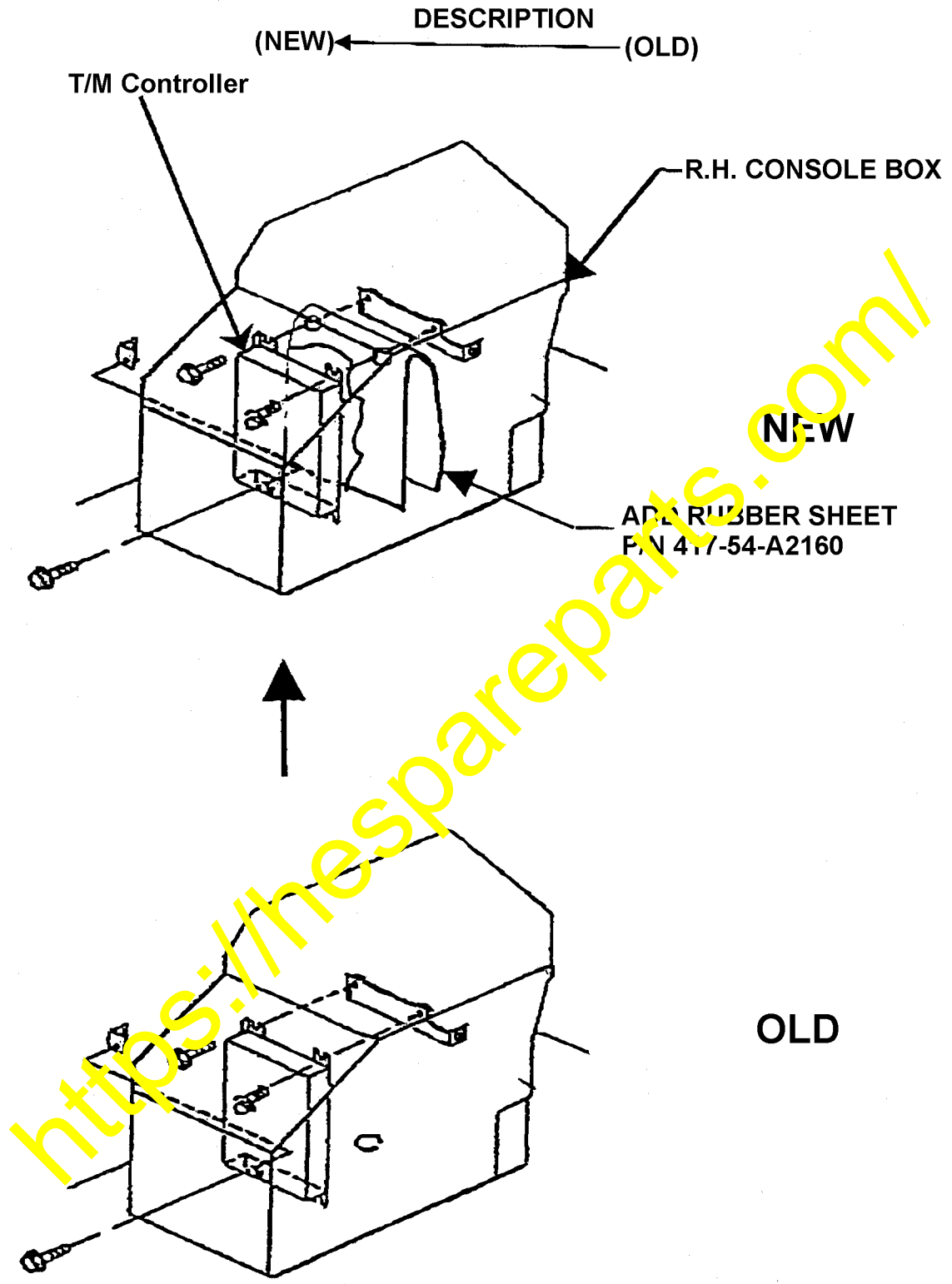

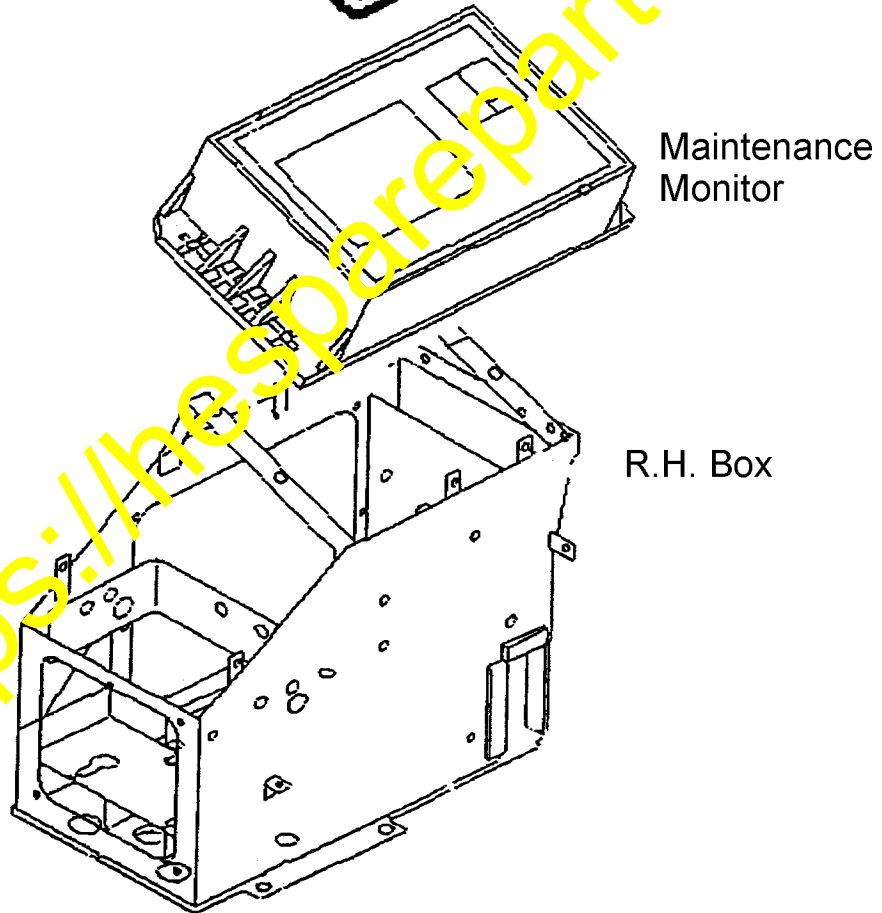
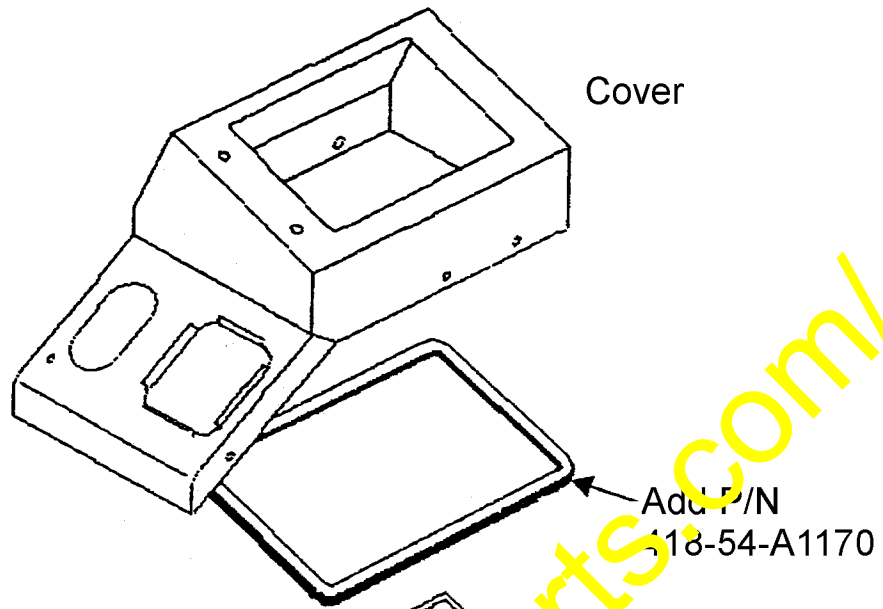

VLPS0103