

# PARTS & SERVICE NEWS

REF NO.	AA01197
DATE	SEPT 20, 2001

**SUBJECT:** FAN OF THE HYDRAULIC OIL COOLER

**PURPOSE:** Replacement of the fan

**APPLICATION:** PC8000-1 KMG Hydraulic Shovel S/N 12016 and up

**FAILURE CODE:** LA20FF

**DESCRIPTION:**

**1. Exchanging parts:**

Part	Qty.	Old Part	New part
FAN	2	322 664 40 (Steel)	907 066 40 (Aluminum)
BOLT	12	307 806 40	307 805 40

**2. Removing of the steel fan blades (See Drawing)**

1. Remove the bolts (8).
2. Remove the cooler fan blades (4).

**3. Installing of the aluminum fan blades**

1. Install the new fan blades (907 066 40) with new screws (307 805 40)

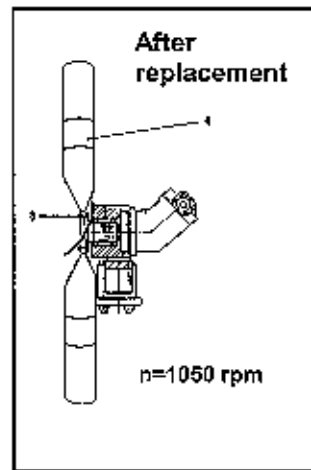
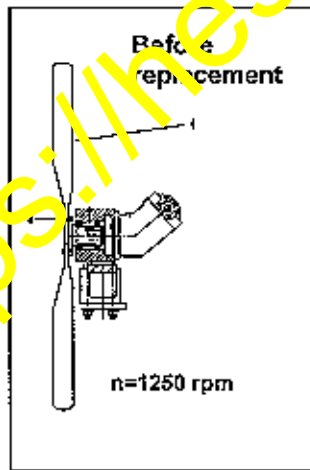

*After replacement of the fan blades adjust the fan rpm to n=1050 rpm.*

**REFER TO SERVICE MANUAL SECTION 4.**