

PARTS & SERVICE NEWS

REF NO. AA02191

DATE August 8, 2002

Page 1 of 3

- SUBJECT:** INTRODUCTION OF LARGE DIAMETER TIRE RIMS WITH IMPROVED DURABILITY
- PURPOSE:** To introduce improved rims with increased durability for the large diameter tires 29.5-25.
- APPLICATION:** WA500-3 Wheel Loader Serial Number 50001 and up
WA500-3L Wheel Loader Serial Number A70001 and up
WA500-3LK Wheel Loader Serial Number A71001 thru A71170
- FAILURE CODE:** 3A20HB
- DESCRIPTION:**

1. Introduction:

When the WA500-3 wheel loaders equipped with the large diameter tires 29.5-25 are operated severely such as making abrupt turns under loaded state frequently, cracks may occur in the welded section between the rim base and the disc.

For the machines being operated as mentioned above frequently, improved rims with increased durability have been developed and this Parts & Service News will introduce these improved new rims.

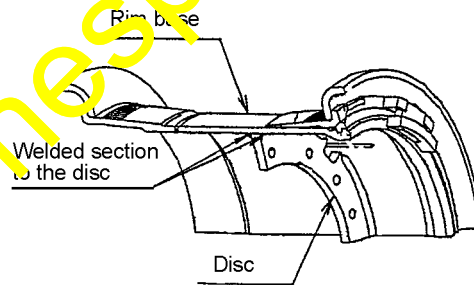

2. List of Parts

Part No.	Part Name	Q'ty	Remarks
Ⓐ 425-W31-2101 (425-W31-2100)	Wheel A. (Wheel A.)	4 (4)	Made by TITAN
Ⓐ 425-W31-2201 (425-W31-2200)	Wheel A. (Wheel A.)	4 (4)	Made by TOPY
Ⓐ 425-W36-2101 (425-W36-2100)	Wheel A. (Wheel A.)	4 (4)	Made by TOPY (For the water ballast spec.)
☆ 425-W31-2111 (425-W31-2110)	Rim base (Rim base)	4 (4)	Made by TITAN
☆ 425-W31-1112 425-W31-1111	Rim base (Rim base)	4 (4)	Made by TOPY
☆ 425-W36-1112 425-W36-1111	Rim base (Rim base)	4 (4)	Made by TOPY (For the water ballast spec.)

※ Parts marked Ⓐ : Necessary when making the replacement in the wheel ass'y state.
 Parts marked ☆ : Necessary when making the replacement of the rim base only.

3. Contents of the modification

The welding between the rim base and the disk has been changed from 10 to 10 x 20 unequal leg length welding to increase the durability.

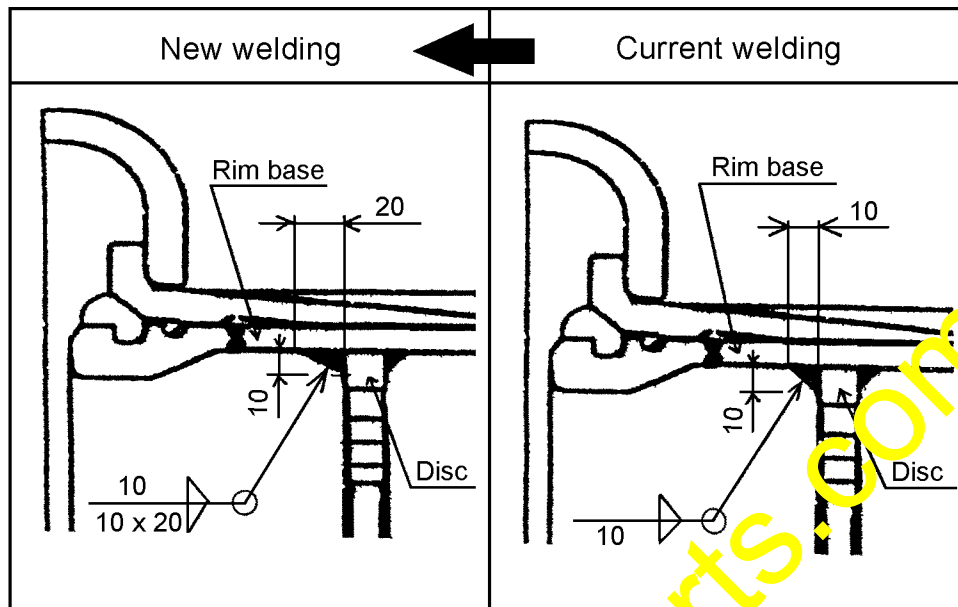

4. Part Number of the component parts of the wheel assembly

	Part No.		Remarks
	New parts ←	Current parts	
A(Wheel ass'y)	425-W31-2101	425-W31-2100	Made by TITAN
	425-W31-2201	425-W31-2200	Made by TOPY
	425-W36-2101	425-W36-2100	Made by TOPY (For the water ballast spec.)
B(Rim base)	425-W31-1111	425-W31-2110	Made by TITAN
	425-W31-1112	425-W31-1111	Made by TOPY
	425-W36-1112	425-W36-1111	Made by TOPY (For the water ballast spec.)

