

PARTS & SERVICE NEWS

REF NO.	AA02192
DATE	August 8, 2002

SUBJECT: MODIFICATION PROCEDURE OF CUT-OFF VALVE ELBOW CRACK

PURPOSE: To introduce modification procedure to repair or prevent occurrence of cracks in the elbow for the cut-off valve piping.

APPLICATION: WA500-3 Wheel Loader Serial Number 50001 thru 52007
 WA500-3L Wheel Loader Serial Number A70001 and up
 WA500-3LK Wheel Loader Serial Number A71001 thru A71114

FAILURE CODE: 6A51HA

DESCRIPTION:

1. Introduction

There is a possibility of occurrence of cracks in the screwed section of the elbow for the return piping to the cut-off valve on the WA500-3 wheel loaders by excessive tightening torque or by frequent cut-off operations.

When the aforementioned cracks are occurring implement the modification being introduced in this Parts & Service News to replace the elbow to the improved one.

2. List of Parts

Part Number	Description	Purpose of Part	Qty	Remarks
426-62-23730 (07235-50628)	Elbow (Elbow)	Replacement	1 (1)	Interchangeable in a set with 07235-10210
07235-10210 (19M-60-15320)	Elbow (Elbow)		1 (1)	Interchangeable in a set with 426-62-23730
07002-11423	O-Ring	Addition	1	
07002-12434 (07002-12434)	O-Ring O-Ring	Replacement	1 (1)	

<https://mespareparts.com/>

3. Contents of the modification

The elbow has been changed from the PT 1/8 type to the O-Ring boss type to increase the strength of the screwed section.

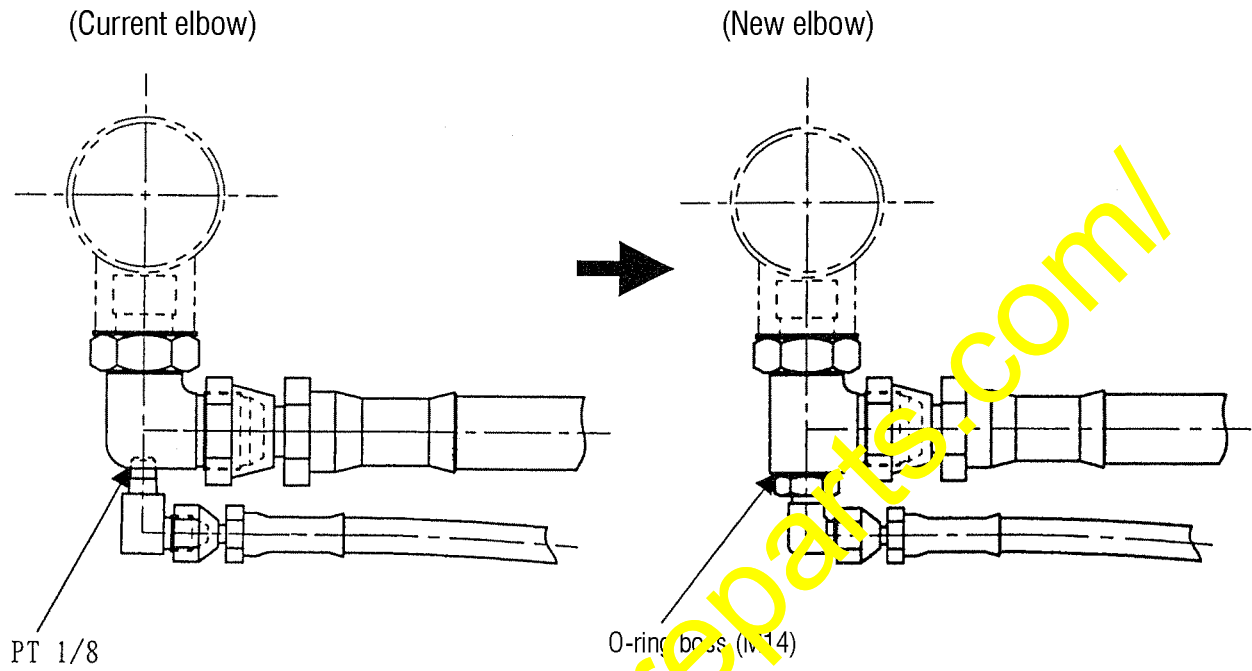

4. Installation procedure

Remove the current elbow for the return piping to the cut off valve and install the newly arranged elbow in replacement.

(Notes)

- Parts in are the newly arranged parts.
- Tightening torque for the elbows for the O-ring boss

Unit: Nm {kgm}

Screw dia. (mm)	Width across flat (mm)	Torque range	Target torque
14	19	35 - 63 {3.5 - 6.5}	44 {4.5}
24	36	1128 - 186 {13.0 - 19.0}	157 {16.0}

