

# PARTS & SERVICE NEWS

REF NO.	AA03064
DATE	April 15, 2003

**SUBJECT:** REROUTE TRANSMISSION HARNESS

**PURPOSE:** To prevent harness contact with hydraulic tube.

**APPLICATION:** WA600-3L Wheel Loader Serial Number A52001 to A52224  
WA600-3LK Wheel Loader Serial Number A53002 to A53036

**FAILURE CODE:** D5Z0Z9

**DESCRIPTION:** The current routing of the transmission harness allows it contact one of the transmission hydraulic tubes. Over time harness failure may occur due to the wires rubbing against the tube. To prevent this from occurring reroute the harness as outlined in this News.

## PARTS

No new parts are required.

## PROCEDURE

1. Disconnect the transmission harness 426-06-22182 from the floor harness and remove the clip from the T/M as shown in A. Do not discard the clip and bolt, they will be reused.

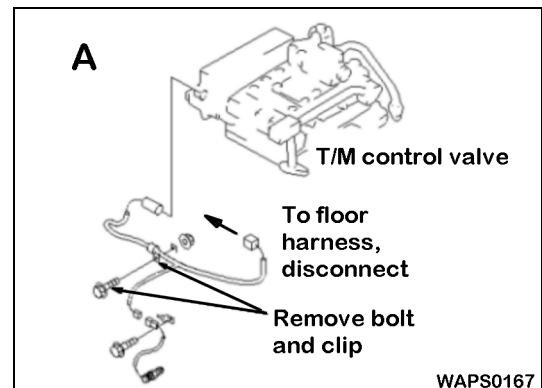
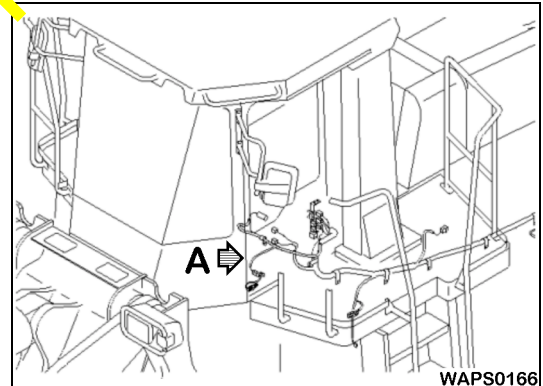

2. The current and new clip mounting locations.

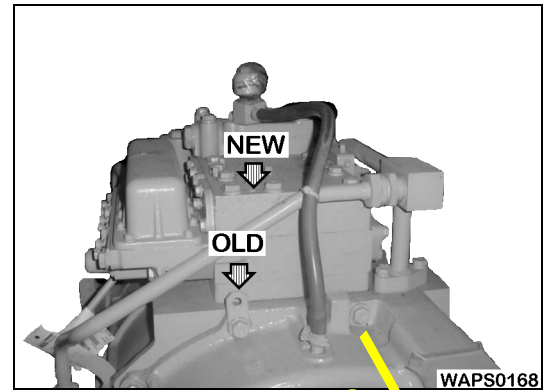

3. Route the harness over the transmission vent hose and tubes.

4. Install the removed clip with bolt in the new location on top of the T/M control valve.

★ When clipping the harness, make sure there is sufficient slack at the T/M connection to prevent the wires from being pulled against the connector body.

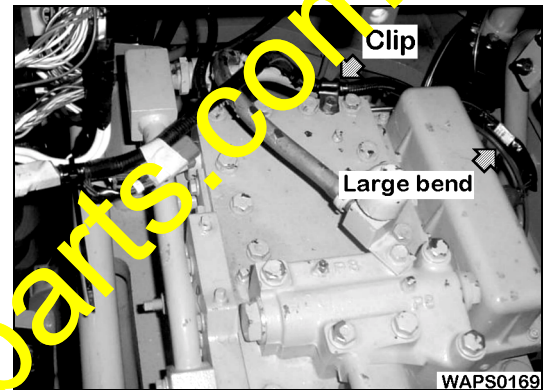

5. Reconnect the transmission harness to the floor harness.

6. Tie strap the transmission harness at connector LR6 to prevent excessive movement.

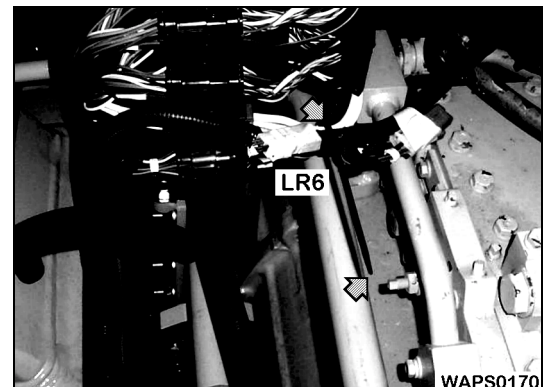

<https://hespareparts.com/>