

PARTS & SERVICE NEWS

REF NO.	AA97035A
DATE	October 16, 1997

Page 1 of 3

This **PARTS & SERVICE NEWS** supercedes AA97035 dated March 24, 1997 and should be discarded.

SUBJECT: DRAWBAR LIFT CYLINDER YOKE AND TRUNNION BUSHINGS

PURPOSE: To provide a kit to replace worn drawbar lift cylinder yoke and trunnion bushings

APPLICATION: GD530A Motor Graders, S/N 200840 and up
 GD530AW Motor Graders, S/N 200840 and up
 GD650A Motor Graders, S/N 200840 and up
 GD650AW Motor Graders, S/N 200840 and up
 GD670A Motor Graders, S/N 200840 and up
 GD670AW Motor Graders, S/N 200840 and up
 830 Motor Graders, S/N 100000 and up
 850 Motor Graders, S/N 100000 and up
 870 Motor Graders, S/N 100000 and up

DESCRIPTION:

Introduction:

This **PARTS & SERVICE NEWS** releases **1438360H91** Lift Bushing service kit which contains:

Part number highlighted below has been corrected.

PART NUMBER	QTY.	DESCRIPTION
1438360H91	4	Bushing, T-Arm (Suspension Arm) - Undersize
142021	4	Bushing, Trunnion

Removal Procedure

1. Remove drawbar lift cylinder by removing four bolts (1) and caps (2) from lift cylinder yoke (3).
2. With suitable lifting device, lift cylinder (4) with trunnion bushings (5) from lift cylinder yoke (3). Lean cylinder against grader frame and secure to prevent cylinder from falling.
3. Remove three bolts and washers (6) from lift yoke retainer (7) and slide yoke (3) from suspension arm (8).
4. Press two bushings (9) from suspension arm (8) and discard.

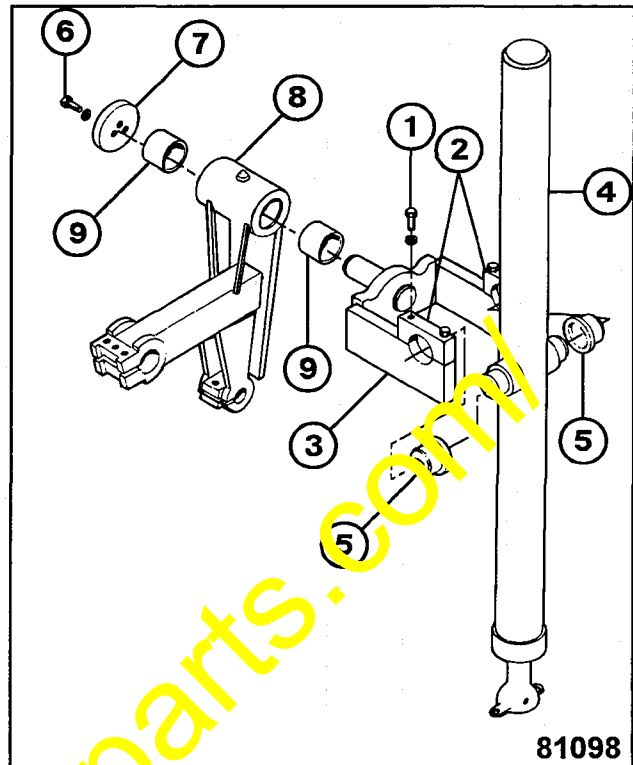

Figure 1

Reassembly

1. Press new 1438325H1 bushings (9) into suspension arm.
2. Try inserting yoke into suspension arm bushings. The new bushings are undersize and may be too tight. DO NOT REAM BUSHINGS, use a ball hone (Figure 2) and hone the bushings until yoke can be inserted with .001 to .004 inch diametrical clearance.

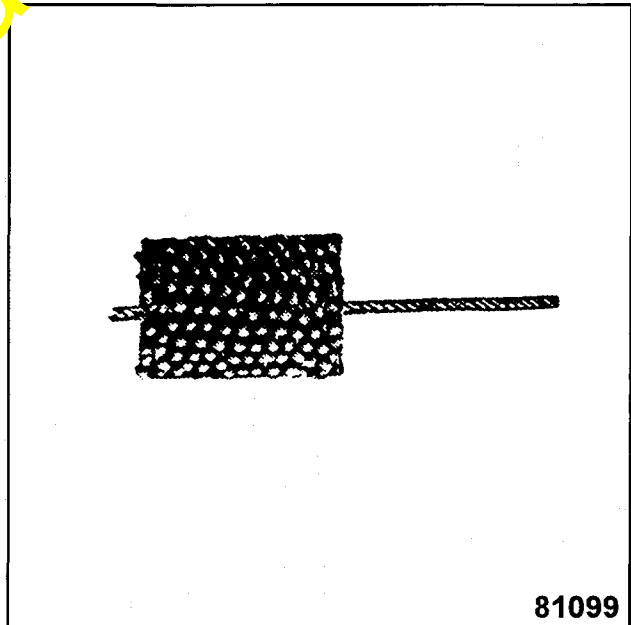

Figure 2 Ball Hone

3. Install yoke retainer (1) using three bolts and washers (2). Tighten to 82 lbf ft.
4. Remove trunnion bushings (3) from lift cylinder (4); remove grease fittings (5) from bushings and discard bushings.
5. Install grease fittings (5) into new 142921 trunnion bushings (3) and place bushings on cylinder trunnions.
6. Using suitable lifting device, lift cylinder into yoke (6) and install caps (7) with bolts and washers (8). Tighten to 140 lbf ft.
7. Apply Komatsu America Super grease to grease fittings (5 & 9).

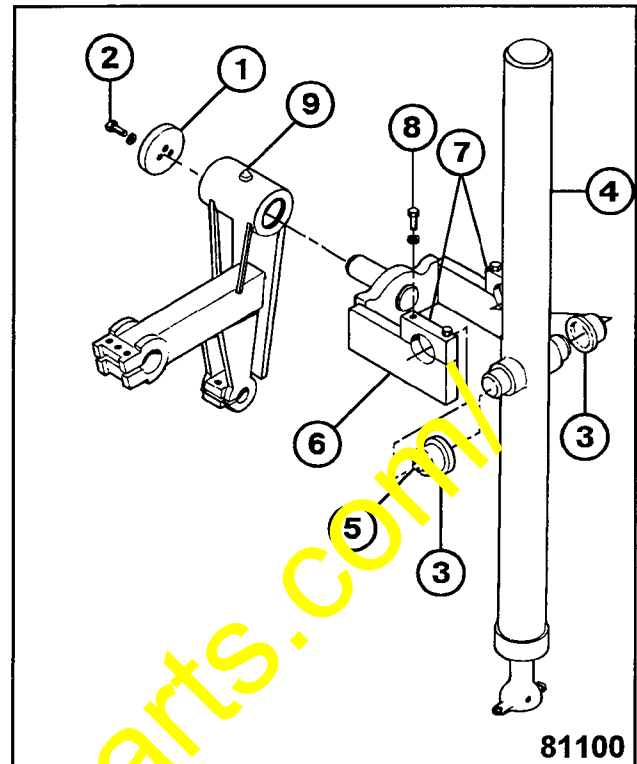

Figure 1

<https://hespareparts.com/>

<https://hespareparts.com/>