

PARTS & SERVICE NEWS

REF NO.	AA97082
DATE	June 4, 1997

Page 1 of 2

SUBJECT: O-RING SEAL REPLACED

PURPOSE: To provide improved sealing

APPLICATION: 210M (BFA-36, 40), equipped with rear axle oil disc brakes

DESCRIPTION:

Introduction:

A new O-Ring seal, P/N WA4795, has been introduced for use in the rear axle area of the 210M. This O-Ring - item 16 - Figure 15374A (Pg. 2), replaces WA4789 when used in the applicaiton. The new O-Ring utilizes a seamless design for improved sealing of the oil-cooled brake assembly onto the rear axle.

When installing the new O-Ring, be sure that the mating surfaces of the axle and brake assembly are clean, and free of burrs. The use of a sealant such as "Permatex Aviation Form-A-Gasket #3D" is permissible when installing this O-Ring seal. Use care to prevent this material from entering areas not intended.

New Part Number

WA4795

Previous Part Number

WA4789

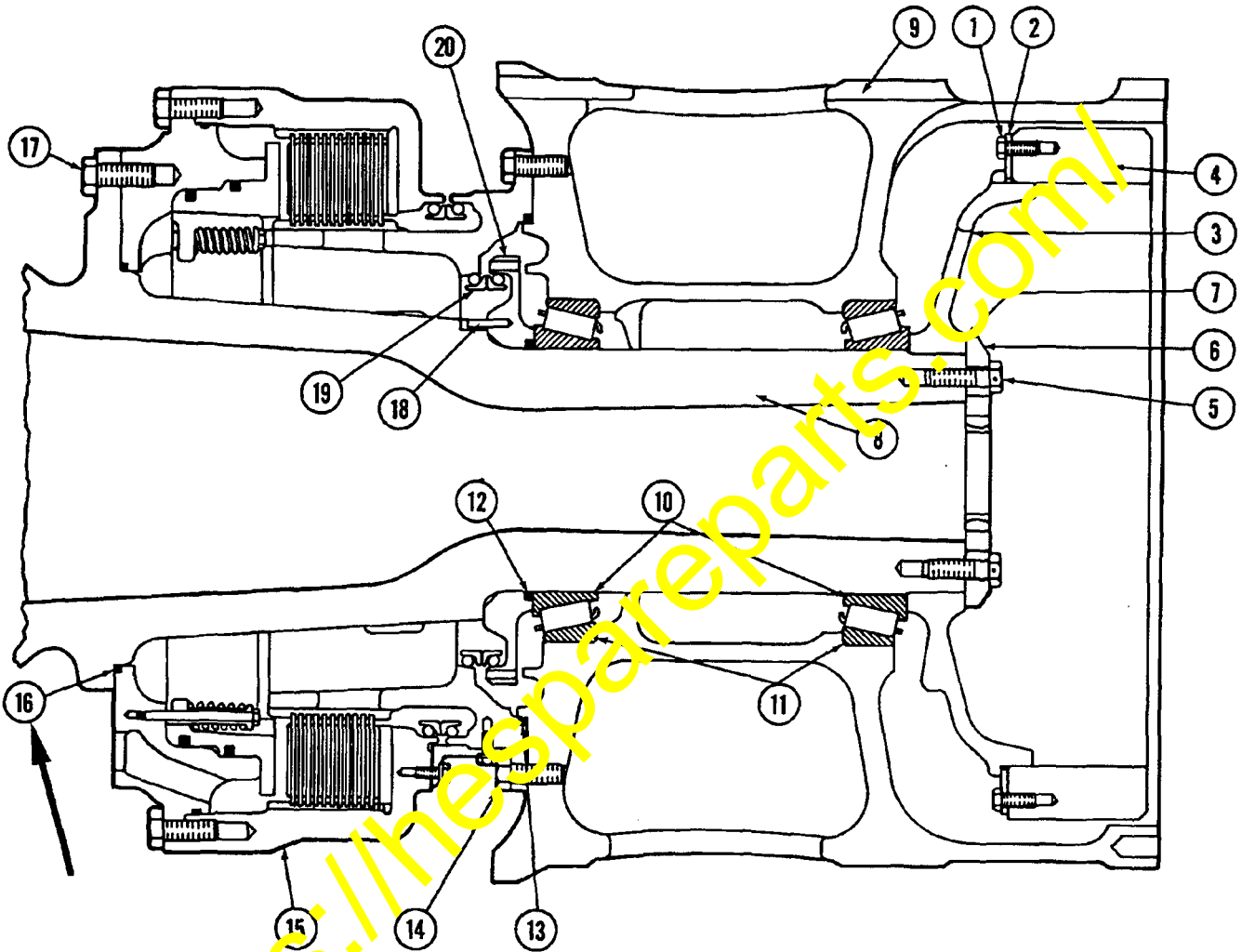

FIG. 15374A
FINAL DRIVE ASSEMBLY