

# PARTS & SERVICE NEWS

REF NO.	AA97156
DATE	September 12, 1997

Page 1 of 2

**SUBJECT:** SEALING CAB PRESSURIZER FILTER

**PURPOSE:** To prevent unfiltered air from entering the operator's compartment

**APPLICATION:** GD530A Graders S/N 200840 and up  
 GD530AW Graders S/N 200840 and up  
 GD650A Graders S/N 200840 and up  
 GD650AW Graders S/N 200840 and up  
 GD670A Graders S/N 200840 and up  
 GD670AW Graders S/N 200840 and up  
 830 Graders S/N 100496 and up  
 850 Graders S/N 100477 and up  
 870 Graders S/N 100481 and up

## DESCRIPTION:

### Introduction:

This presents the procedure for sealing the Cab Pressurizer Filter. The following bulk seal material will be needed:

Part Number	Qty.	Description
140828	74"	Bulk Seal

1. Remove four 180020 bolts and 120392 washers (1) to release filter retainer (2) & filter (3).
2. Remove sealing material (4) from filter retainer (2)

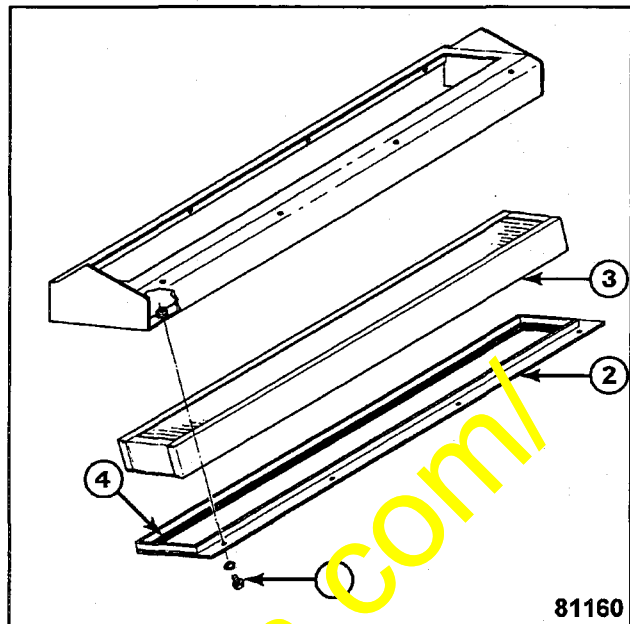

3. Cut 140828 bulk sealing material into two 6" strips (1) and two 31" strips (2).
4. Expose seal adhesive and apply seals around opening inside filter housing (3).
5. Reinstall filter (4) and filter retainer (5) using four 180020 bolts and 120392 washers (6).

