

PARTS & SERVICE NEWS

REF NO. AA97180B

DATE December 16, 1998

Page 1 of 2

This Parts & Service News supercedes AA97180A dated FEB. 25 1998 and should be discarded.

SUBJECT: ENGINE GROUND

PURPOSE: Provide electrical grounding for engine.

APPLICATION: GD650A Graders Serial Number 200840 thru 203240
 GD650AW Graders Serial Number 200840 thru 203240
 GD670A Graders Serial Number 200840 thru 203240
 GD670AW Graders Serial Number 200840 thru 203240
 850 Graders Serial Number 100477 thru 203240
 870 Graders Serial Number 100481 thru 203240

DESCRIPTION:

Introduction:

Due to an intermittent ground, the engine gauges may not give accurate readings. Providing a ground cable from engine to frame will alleviate this problem.

The following parts will be needed:

Part Number	Qty.	Description
1434035H1	1	Ground Cable
30527R1	1	Bolt - M12x20
25546R1	1	Flat Washer

– NOTE –

The information in this **PARTS & SERVICE NEWS** does not authorize or imply any obligation on the part of Komatsu America International Company to provide reimbursement for any expenses. Machines requiring part repair or part replacement during the machine warranty are covered under normal warranty. Out-of-warranty machines are the responsibility of the distributor/customer.

INSTALL ENGINE GROUND CABLE

1. Clean boss on engine (2), and ground boss on frame (3) of dirt, paint and rust.
2. Install 1434035H1 cable (1) to engine with 30527R1 bolt and 25546R1 flat washer (2). Use lubriplate or other electrical grease.
3. Attach other end of cable (1) to frame under ground cable with existing hardware (3). Use lubriplate or other electrical grease.

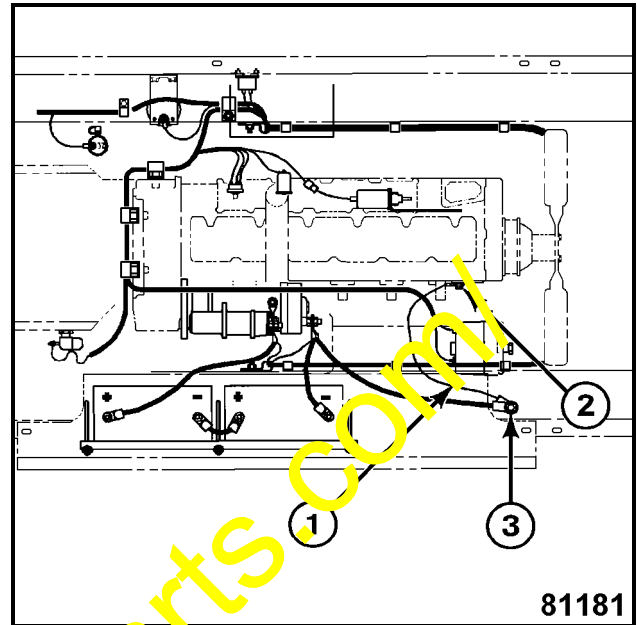

Figure 1