

PARTS & SERVICE NEWS

REF NO.	AA98174
DATE	November 18, 1998

(C)

Page 1 of 2

SUBJECT: AWD BREATHER RETENTION

PURPOSE: To insure that breathers are properly positioned.

APPLICATION: GD530A/AW Graders Serial Number 202000 thru 203709
 GD650A/AW Graders Serial Number 202000 thru 203709
 GD670A/AW Graders Serial Number 202000 thru 203709
 830 Graders Serial Number 200000 thru 203709
 850 Graders Serial Number 200000 thru 203709
 870 Graders Serial Number 200000 thru 203709

FAILURE CODE: 2A1316

DESCRIPTION:

Introduction:

Adding a clamp to the tie plate in the headblock and clamping the AWD vent hoses will prevent the breathers from coming in contact with water which may collect inside the headblock; thus eliminating entry of water into the AWD gear cases.

– NOTE –

The information in this **PARTS & SERVICE NEWS** does not authorize or imply any obligation on the part of Komatsu America International Company to provide reimbursement for any expenses. Machines requiring part repair or part replacement during the machine warranty are covered under normal warranty. Out-of-warranty machines are the responsibility of the distributor/customer.

Remove two bolts and washers holding front cover plate and remove.

Drill a .375" to .437" hole in the tie plate as indicated at "A" of Figure 1.

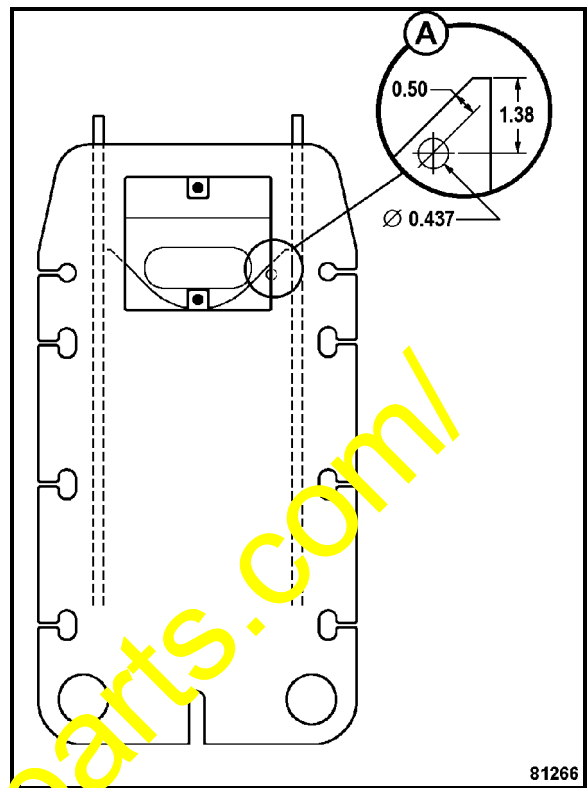

Figure 1

On the back side of tie plate (1, Figure 2) install 130096 clamp (2) around vent hoses (3) with 140483H bolt, 25534R1 flat washer, and 25522R1 hex nut.

Insure that the breather vents (4) are vertical as illustrated and cannot fall.

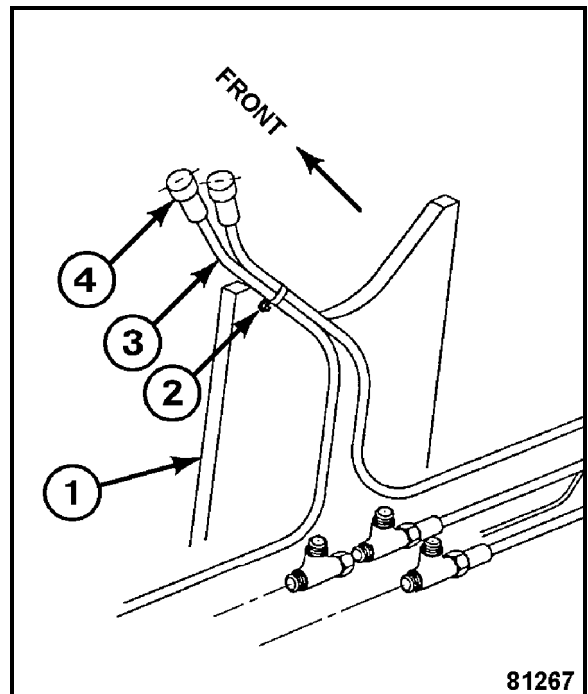

Figure 2