

# PARTS & SERVICE NEWS

REF NO.	AA99002
DATE	Dec. 28, 1998

Page 1 of 2

**SUBJECT:** IMPROVED BELL CRANK PIN

**PURPOSE:** To introduce an improved bell crank pin

**APPLICATION:** WA800-1 Wheel Loaders, S/N 10001 and up  
 WA800-2 Wheel Loaders, S/N 10001 and up  
 WA800-2LC Wheel Loaders, S/N 10001 and up  
 WA800-3 Wheel Loaders, S/N 50001 thru 50005  
 WA900-1 Wheel Loaders, S/N 10001 and up  
 WA900-1LC Wheel Loaders, S/N A20001 thru A20019  
 WA900-3 Wheel Loaders, S/N 50001 thru 50003

**FAILURE CODE:** 772E99

**DESCRIPTION:**

1. Introduction

This Service News will introduce an improved and more durable bell crank pin (featuring a new material) for use on WA800 and WA900 wheel loaders.

2. List of parts

Part No.	Part Name	Qty	Remarks
427-70-11965 (427-70-11964)	Pin (Pin)	1 (1)	

### 3. Contents of the modification

The material of the bell crank center pin has been changed from S45C to SCM435H to increase the durability of the part.

<Current part>

427-70-11964  
Material: S45C



<New part>

427-70-11965  
Material: SCM435H

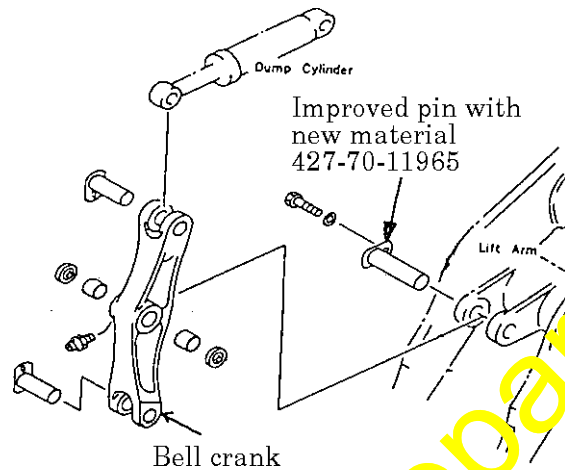

### 4. Precautions when replacing the part

When replacing the bell crank center pin, always apply "LM-P" to the pin and the bushing before installing them, in order to prevent galling or early wear. For details, refer to the previously issued Service News No. AA96202 "PRECAUTION ATTACHMENT ASSEMBLY AT SITE ON WA700, WA800, WA900".