

PARTS & SERVICE NEWS

REF NO.	AA99069
DATE	March 23, 1999

(C)

Page 1 of 2

SUBJECT: INTRODUCTION OF ONE PIECE WRIST REST ADJUSTMENT BAR

PURPOSE: To ease the wrist rest adjustment process
Note: Apply this update in conjunction with FC A9008-01

APPLICATION: WA320-3mc Wheel Loaders, S/N A31056
WA380-3mc Wheel Loaders, S/N A51038
WA420-3mc Wheel Loaders, S/N A31014
WA450-3mc Wheel Loaders, S/N A31013 and A35001

FAILURE CODE: 545199

DESCRIPTION:

Introduction:

A new one-piece wrist rest support bar is released to ease the wrist rest adjustment process for the operator. Follow instructions in this **PARTS & SERVICE NEWS** to remove the displaced two-piece bar, Figure 1 and instal the new one-piece bar.



Procedural Instructions

1. Loosen the lower adjustment lock handle, 1-figure 2. Lift the complete wrist rest and support assembly from the right console.

2. Remove the upper pad attach bolt. Retain the pad and bolt and discard the remaining parts. They are no longer required. Refer to Figure 2.
3. Assemble the previously removed pad to the new support bar, 421-54-23420. Use the old bolt.
4. Slip the new wrist rest support bar through the yoke assembly in the right console, set the correct height and tighten the lower adjustment lock handle to secure the wrist rest in that position. Refer to Figure 3.

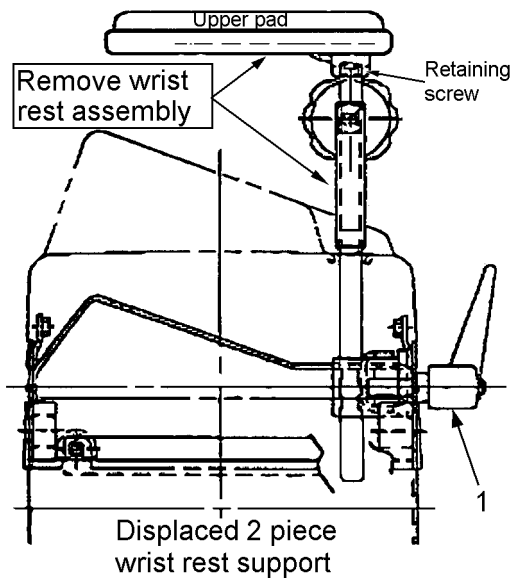

Figure 2

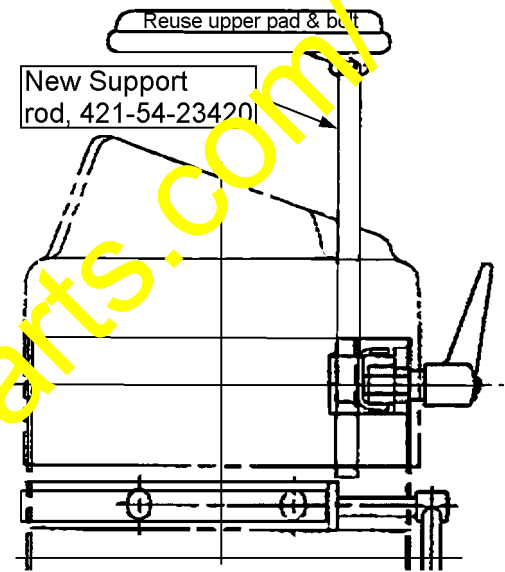

Figure 3