

PARTS & SERVICE NEWS

REF NO. AA99172

DATE November 11, 1999

(C)

Page 1 of 3

SUBJECT: NEW SEAT AVAILABLE FOR 330M / HD785-3

PURPOSE: TO INTRODUCE PRODUCT IMPROVEMENT KIT AK4242

APPLICATION: 330M / HD785-3 HAUL TRUCKS BUILT IN THE U.S. WITH SERIAL NUMBERS A10211 AND BELOW

FAILURE CODE: 571199

DESCRIPTION:

An improved operator's seat is now available for 330M / HD785-3 trucks built in the U.S. with serial numbers A10211 and below. This seat is standard with new production trucks effective with A10212. The seat is a quality, heavy-duty, air suspension seat. Dual dampers (suspension) are standard with this seat. Air supply for seat suspension is provided by the truck's air system. The seat is also equipped with a three inch wide retractable seat belt. *NOTE: The cab floor must be lowered by a structural modification to allow for full range of height adjustments. The structure modifications are part of the AK4242 kit.*

Improvements:

- Heavy duty construction
- Dual dampers
- More Adjustments
 1. Weight \ firmness adjustment
 2. Back rest angle
 3. Front-to-rear-travel
 4. Ride height adjustment
 5. Lumbar support

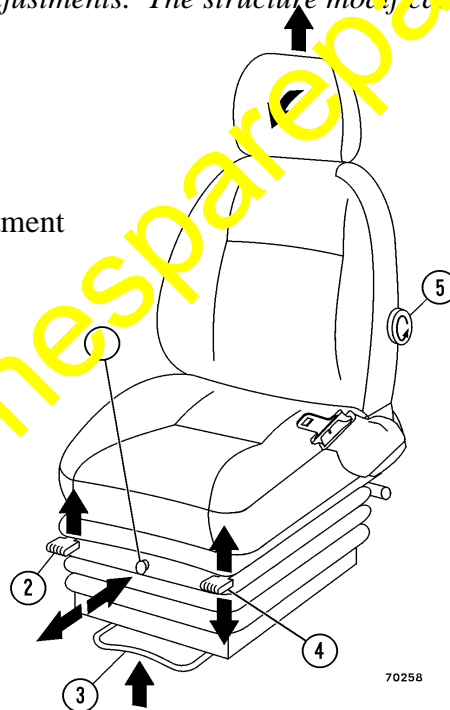

Figure 1. Improvements of New Seat

- | | |
|---------------------------------|----------------------|
| 1. Weight \ Firmness Adjustment | 4. Height Adjustment |
| 2. Backrest Angle | 5. Lumbar Support |
| 3. Front-to-Rear-Travel | |

*NOTE: This installation requires significant cutting and welding operations to the cab floor. **Take all necessary precautions to prevent a fire during cutting and welding operations.** To install the new seat, the floor has to be lowered approximately 3 inches to allow for the full range of seat height adjustments. Refer to Figure 2 for an overview of required cab floor modifications. No other cab, electrical or plumbing changes are required.*

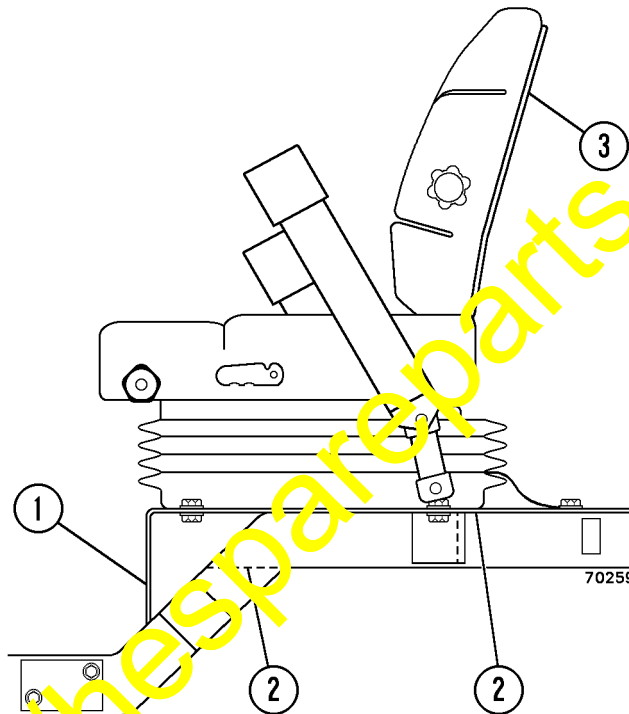

Figure 2. General Overview of Required Modifications

- 1. Seat Support (to be removed)
- 2. Cab Floor (to be cut out)
- 3. Old Seat (to be removed)

Installation Instructions:

1. Remove existing seat and rework cab platform per drawings EH4904 and EH5568.
2. Install new seat (EH7882).
3. Install new belt and tethers (PC0541;PC0564).
4. Instruct operators on seat adjustment.

AK4242 KIT

Part Number	Description	Quantity
EG8845	BAR BACKER	2
EH3218	PAN STR FLOOR	1
EH3219	PLATE	2
EH3220	COVER	1
EH3221	LEVER	1
EH3222	BRACKET	1
EH4903	PLATE	1
EH4904	DRAWING, PLATFORM REWORK	1
EH5568	DRAWING, SEAT INSTALLATION	1
EH5571	CABLE STR	1
PC0541	BELT SET TETHER DRIVER SEAT	1
PC0564	BELT SEAT RETRACTABLE	1
EH7882	SEAT, OPERATOR	1
VH5017	TIE STRAP	2
0102320162	SCREW	3
0125260816	BOLT	4
0143501235	BOLT	4
0803400519	BAND	2
0803601014	CLIP	1