

PARTS & SERVICE NEWS

REF NO.

AH03508

DATE

25th Febr. 2003

Page 1 of 18

SUBJECT: Additional hydraulic oil cooler**PURPOSE:** Information about the possibility of the modification**APPLICATION:** H 485S S/N 12016; H 655S; PC8000-1 S/N 12022; 12024-36)**FAILURE CODE:** 0300NS**DESCRIPTION:**

1. Modification kit (Part No. 924 365 40)
2. Preparations
3. Installation of the auxiliary oil cooler
4. Installation of additional hydraulic parts
5. Hydraulic connections
6. Completion of installation



- Before modification please contact our Komatsu Service Headquarters for altering the Hydraulic Circuit Diagrams of your excavator.

- You will find detailed modification drawings in paper version in size DIN A1 attached to the modification kit.

1. Modification kit 924 365 40:

Position*	Part No.	Qty.	Description
1	92436040	1	Aux. oil cooler
2	92296840	1	Face
3	92297140	2	Threaded block
4	92296940	2	Threaded block
5	30835699	2	Bolt
6	25505640	16	Washer
7	51220098	2	Bolt
8	92296740	2	Sheet metal
9	92436640	1	Modification parts hydraulic
10	51730198	1	Hose assy. 12x1500
11	51730298	1	Hose assy. 12x1700
12	51446498	1	Hose assy. 10x8350
13	51730698	1	Hose assy. DN32x1850
14	41905940	1	Hose assy. DN40x3880
15	51730798	1	Hose assy. 51730798
16	51496998	1	Hose assy. DN40x4600
17	51730498	1	Hose assy. DN40x2000
18	51730898	1	Hose assy. DN32X2700
19	51730398	1	Hose assy. DN40x3700
20	57629840	1	Hose assy. DN16x1300
21	51271098	1	Hose assy. DN16x4820
22	92439540	1	Rail
23	92439540	1	Ladder
24	50700498	8	Pair of half clamp
25	53400899	8	Cover plate
26	53400999	8	Weld on plate
27	30859999	16	Bolt
28	22648240	2	Flange connection
29	00663498	12	Half flange
30	00672998	8	O-ring
31	31915699	24	Bolt
32	31927499	8	Bolt
33	00663898	16	Half flange
34	35621040	8	Flange seal
35	31920999	32	Bolt
37	37440799	1	Socket
38	51354598	1	Union
39	50261898	5	Pair of half clamp

to be continued.

Modification kit 924 365 40:

Position*	Part No.	Qty.	Description
40	53400499	5	Cover plate
41	53400599	5	Weld on plate
42	51045298	5	Grommet
43	30858199	10	Bolt
44	30857799	4	Bolt
45	51074698	4	Resilient sleeve
46	30777799	4	Bolt
47	50703798	4	Nut
48	34046599	4	Washer
49	37441399	2	Socket
50	50637198	6	Pair of half clamp
51	50572998	6	Grommet
52	53400899	6	Cover plate
53	50287998	4	Bolt
54	33460099	4	Nut
55	34046799	4	Washer
56	51730998	1	Hose assy. DN32x2900
57	50498798	2	Pair of half clamp
58	53398999	2	Weld on plate
59	51185598	5	Cover plate
60	31913299	10	Bolt
61	51595498	4	Bolt
62	51713598	4	Bolt

2. Preparations

1. Remove the hydraulic oil cooler.
2. Machine the holes and increase the threads as shown at drawing.
3. Reinstall the hydraulic oil cooler by using the new bolts (61 and 62) and the washer (6).
(wrench size 55 mm; tightening torque: 3100 Nm).

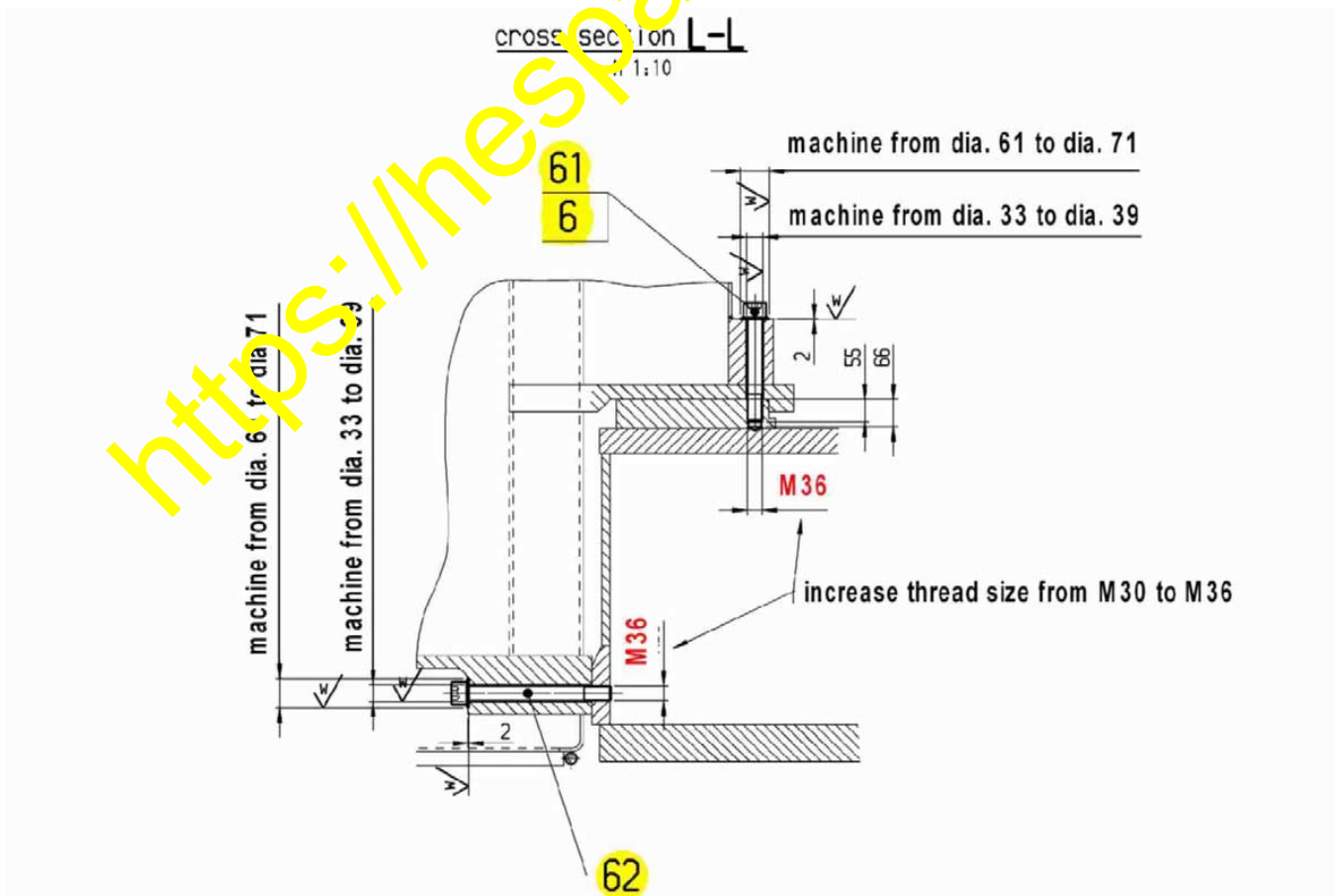
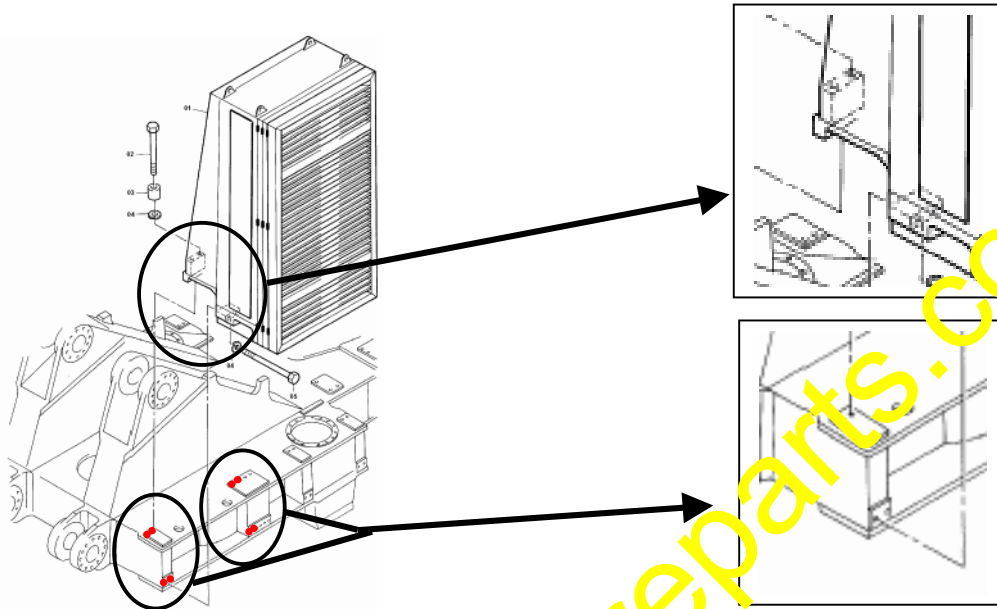

3. Installation of the auxiliary oil cooler

1. Cut the transportation lugs at the top of the hydraulic oil cooler.
2. Weld on the threaded blocks (3 and 4).
3. Use the auxiliary oil cooler as template.

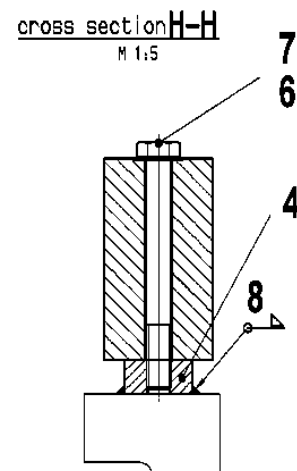
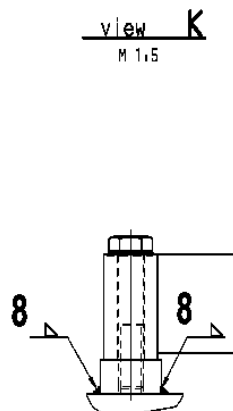
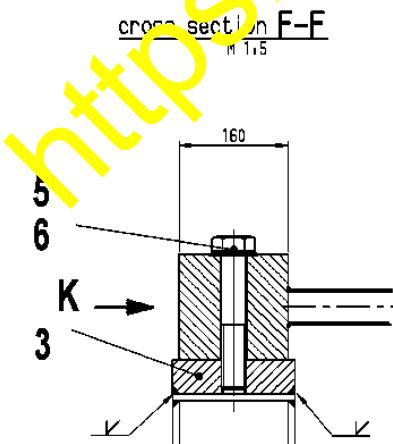
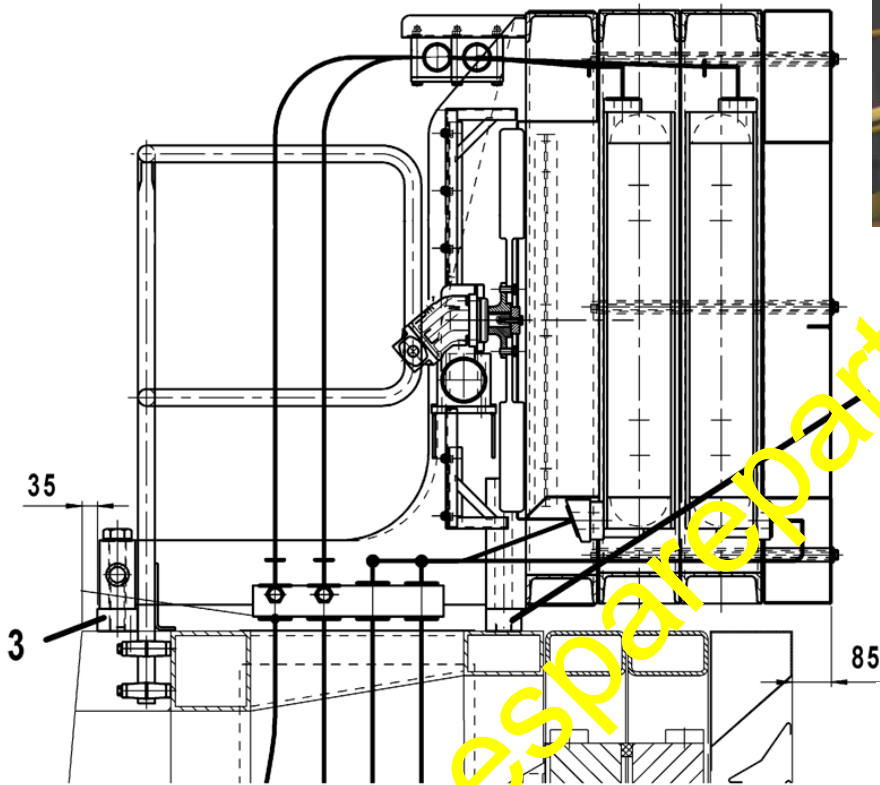

4. Cut a hole 85 x 430 as shown (marked green).
5. Drill 4 holes dia.11 mm and install the face (2) with 2 sheet metals (8) by using of the parts (44 to 48)

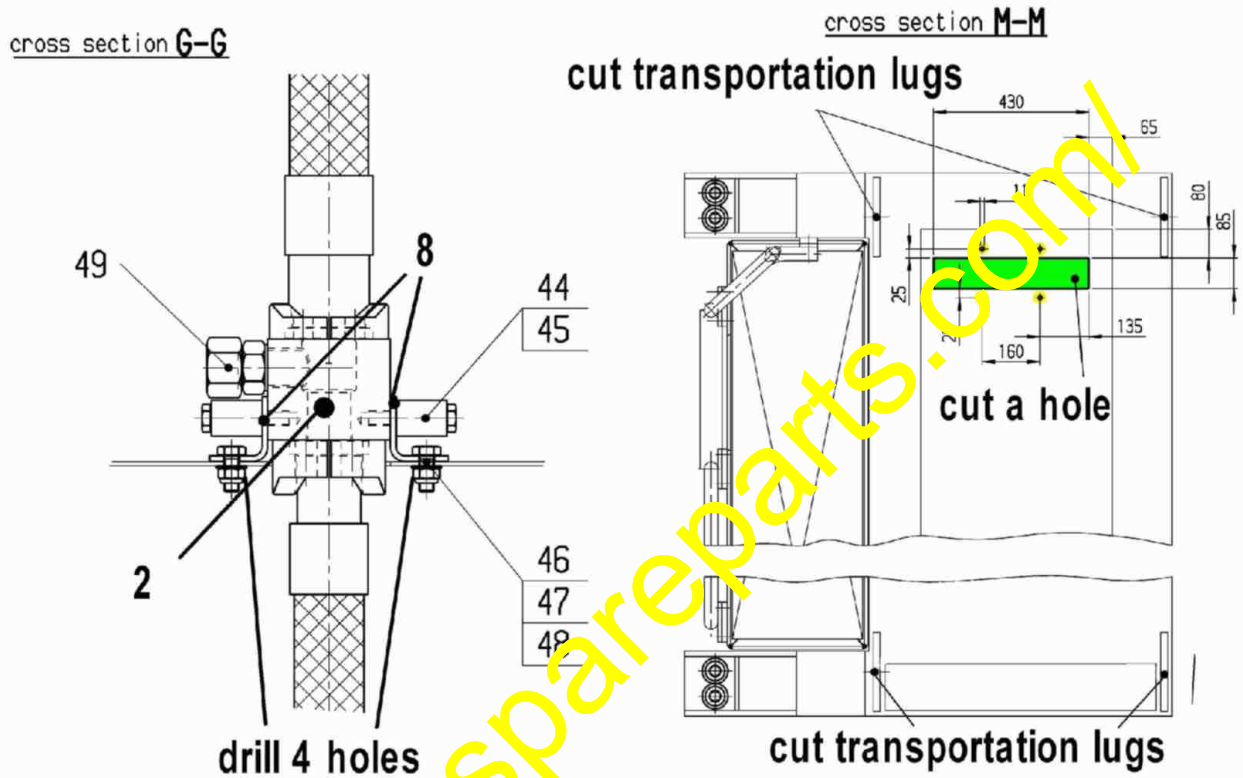

6. Install the auxiliary oil cooler assy. and secure it with the bolts (5 and 7) by using washers (6) (wrench size 55 mm; tightening torque: 3100 Nm).

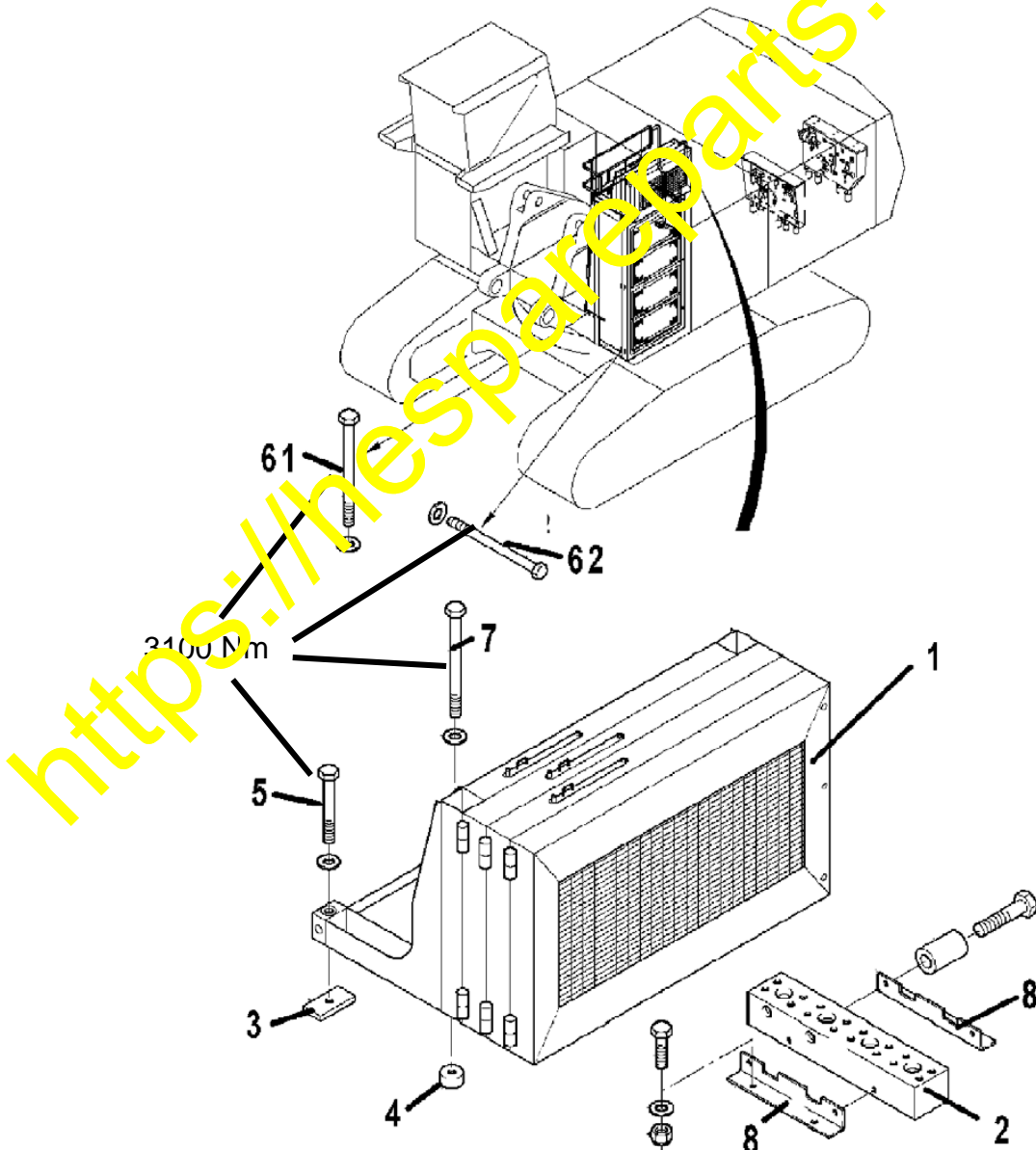

4. Installation of additional hydraulic parts (924 366 40)
(Position (9) of the modification kit)

Position*	Part No.	Qty.	Description
1	20297940	2	Pressure reducing valve
2	20298040	2	Connector plate
3	92296140	2	Plate
4	31926199	8	Bolt
5	30775799	8	Bolt
6	33459999	8	Nut
7	37146099	4	Socket
8	51697198	2	Socket
9	62101440	2	Socket
10	62101440	2	Union
11	51095098	2	Hose assy. DN12x580
12	51696198	2	Socket
13	00413198	2	Test coupling
14	18011340	2	Plug
15	51617598	1	Socket
16	55198740	2	Plug
17	51574998	2	Hose assy. DN10x1200
18	90715240	2	Union
19	51616898	1	Socket
20	51615798	1	Socket

1. Install the 2 Pressure reducing valves as shown at drawing below.
2. Install the new connections at the Control and Filter Plates as shown at the following pages.

Control and Filter Plate (rear)

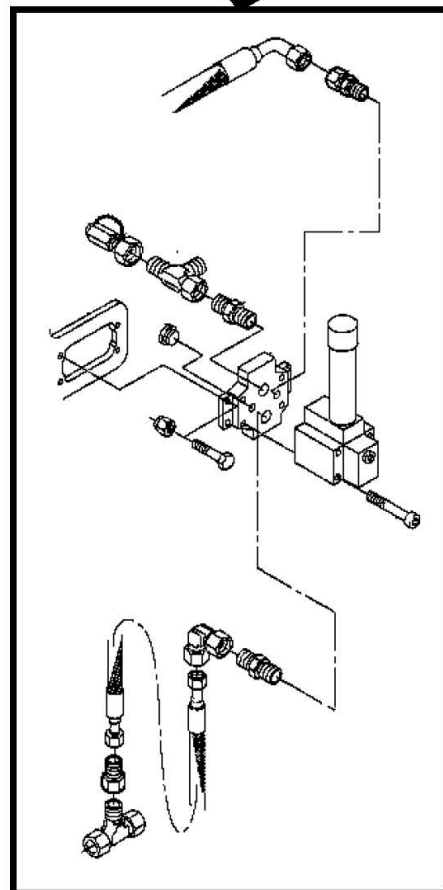
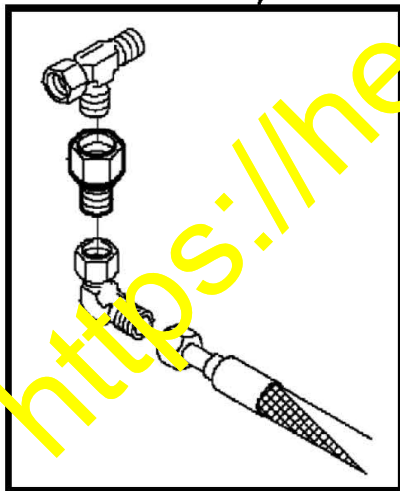
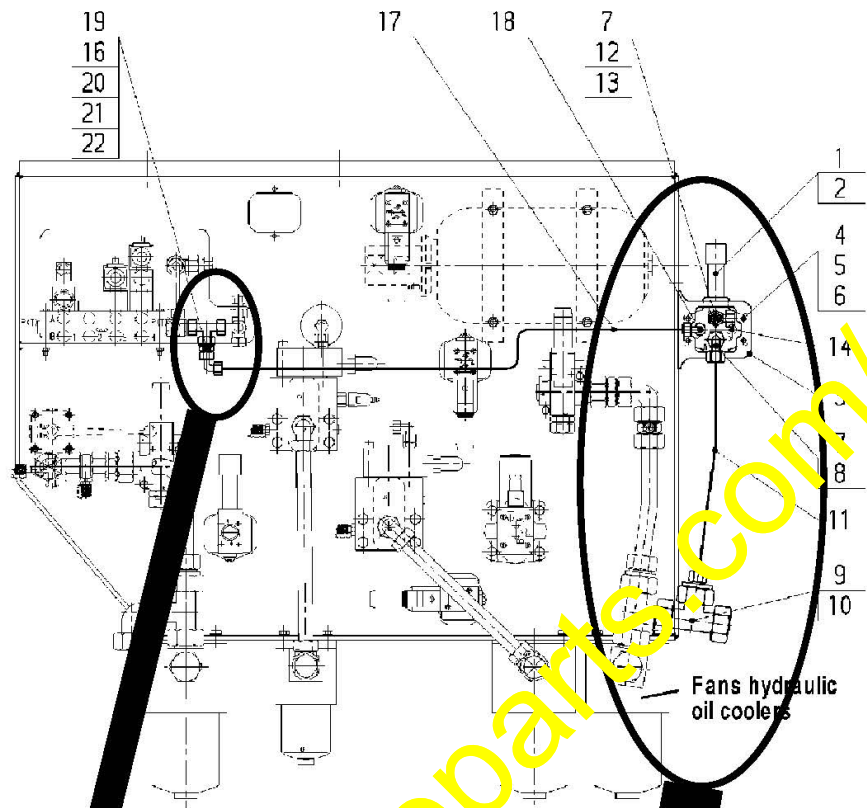

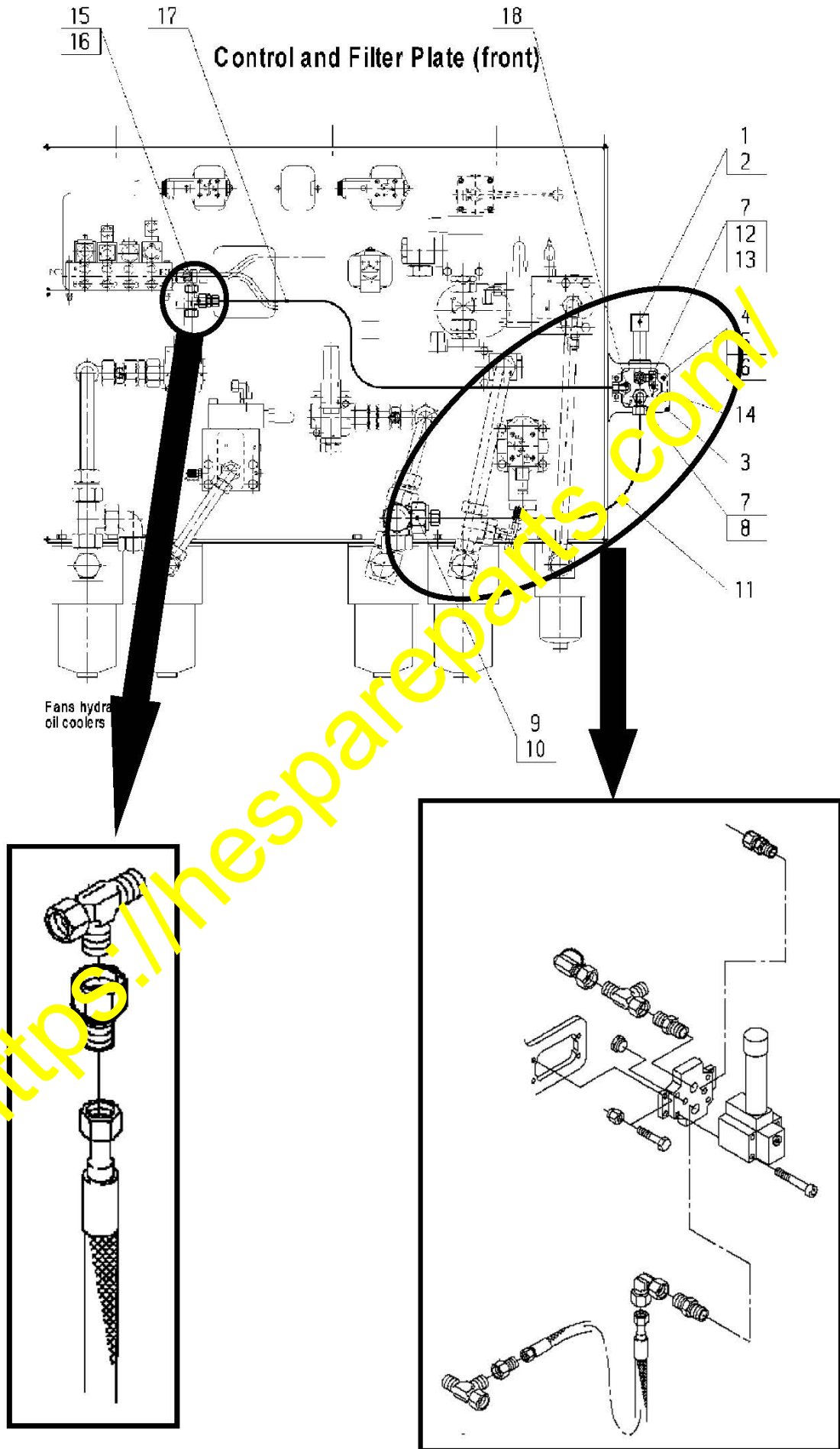

5. Hydraulic connections

Control and Filter Plate (partly)

New Pressure Reducing Valve

Control and Filter Plate (partly)

New Pressure Reducing Valve

Main hydraulic oil coolers

Additional hydraulic oil coolers

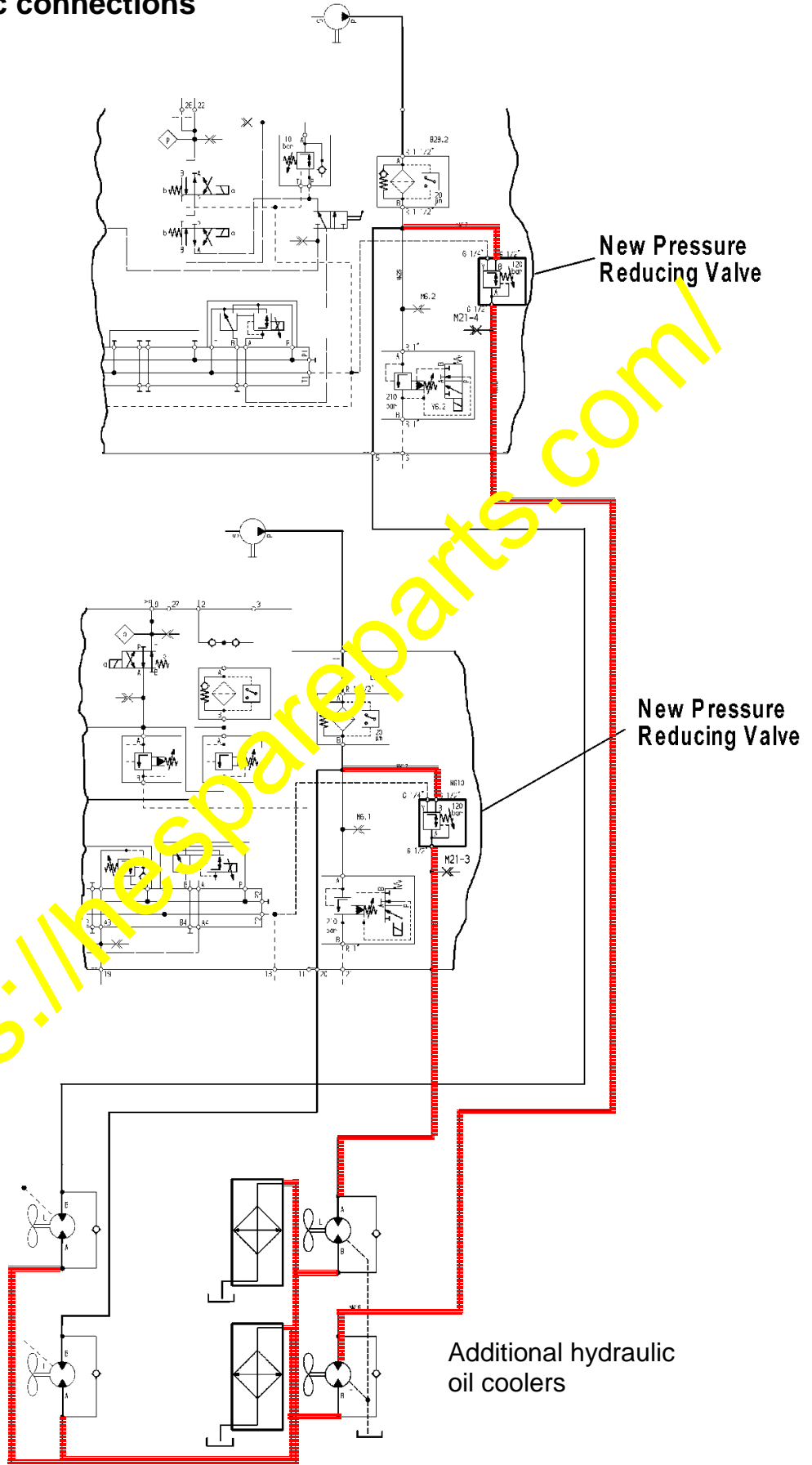

1. Connect the new pressure reducing valves at the control and filter plates directly with the pressure ports at the new fan motors.
2. Remove the return lines from the old fan motors to the tank.
3. Connect each time the return lines from one old fan motor , one new fan motor (from the additional cooler) and one hose from the top of the new coolers to the face.
4. Connect the return lines of the new coolers via the face with the tank.
5. Connect the common leak oil line of the new fan motors with the hydraulic oil tank.

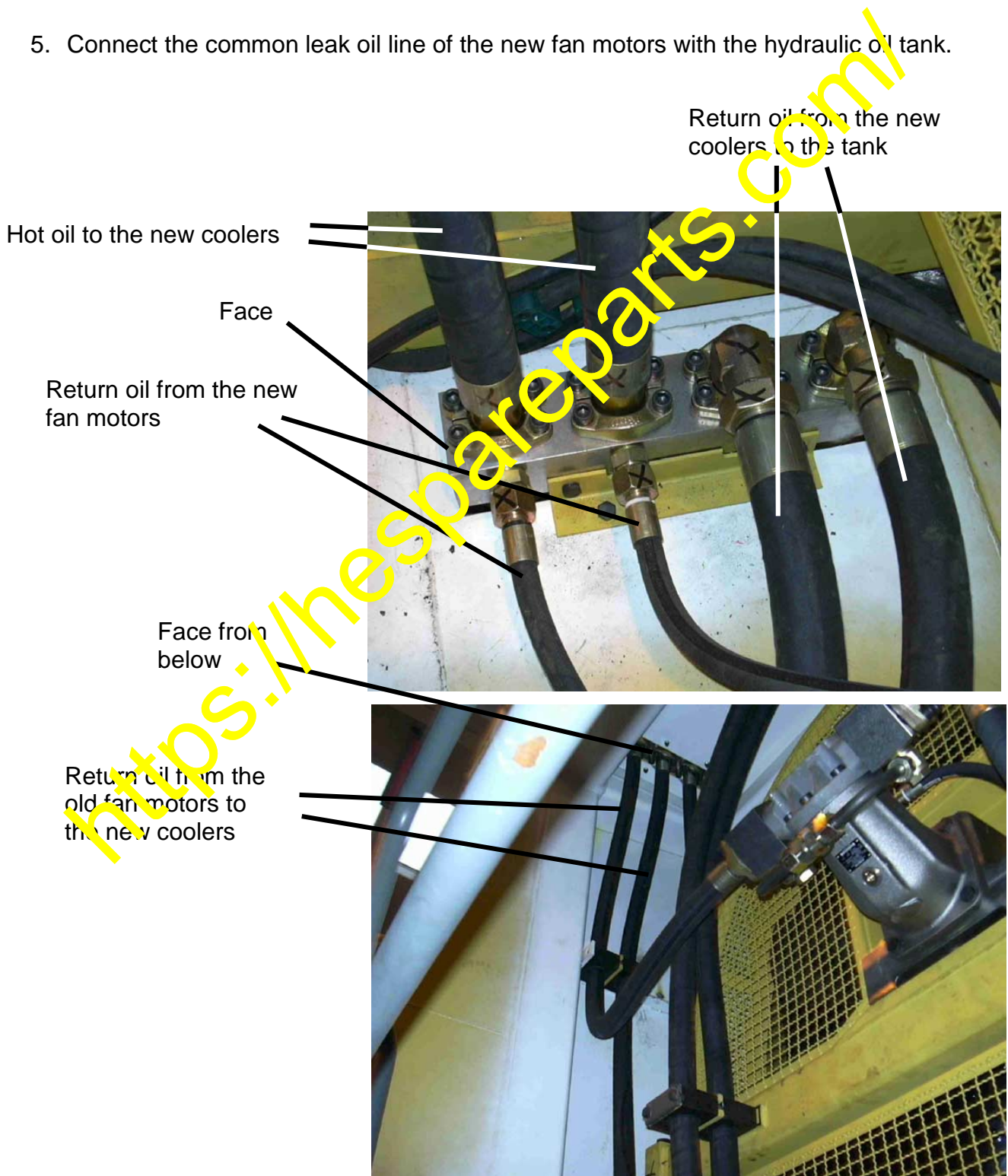

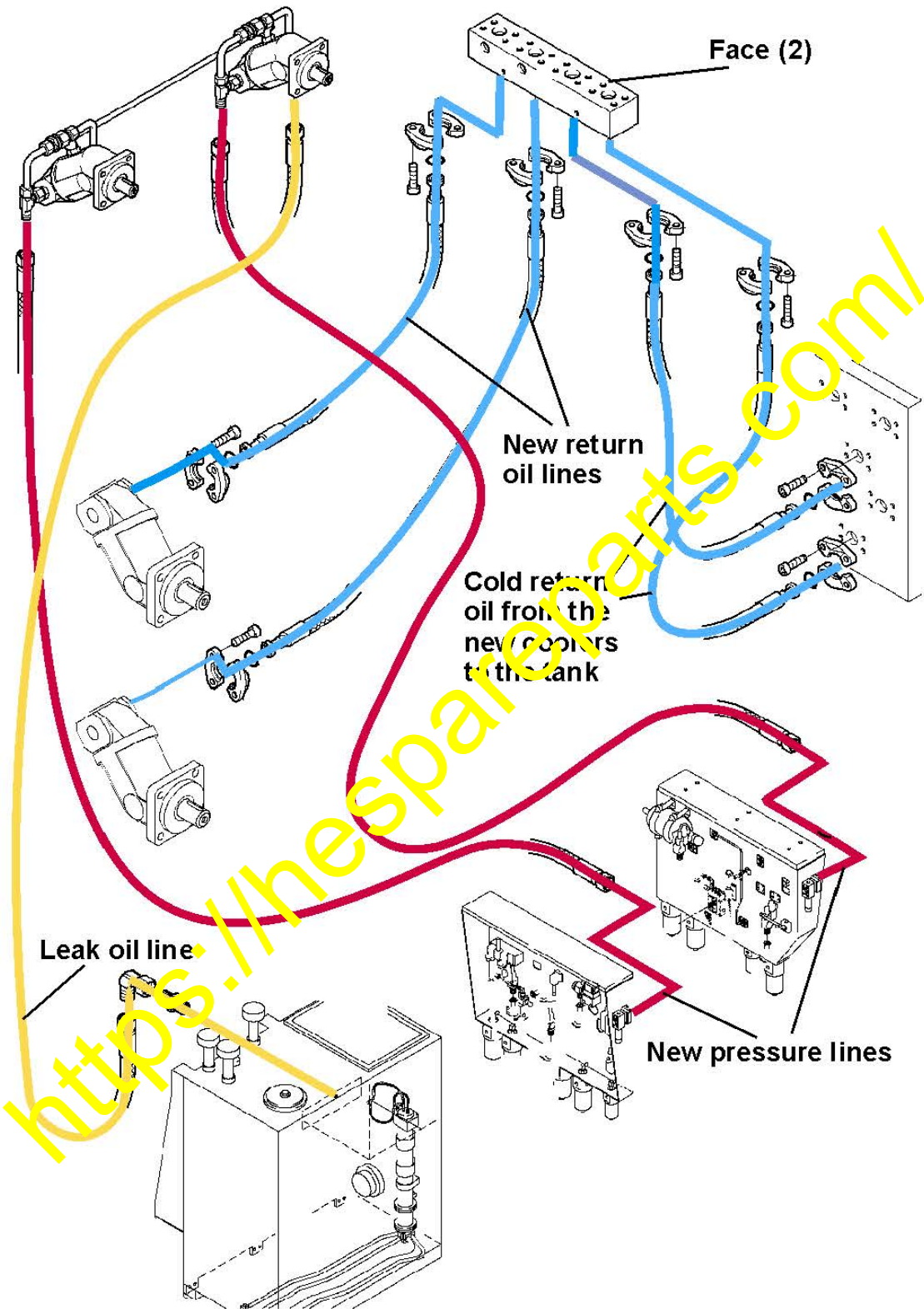

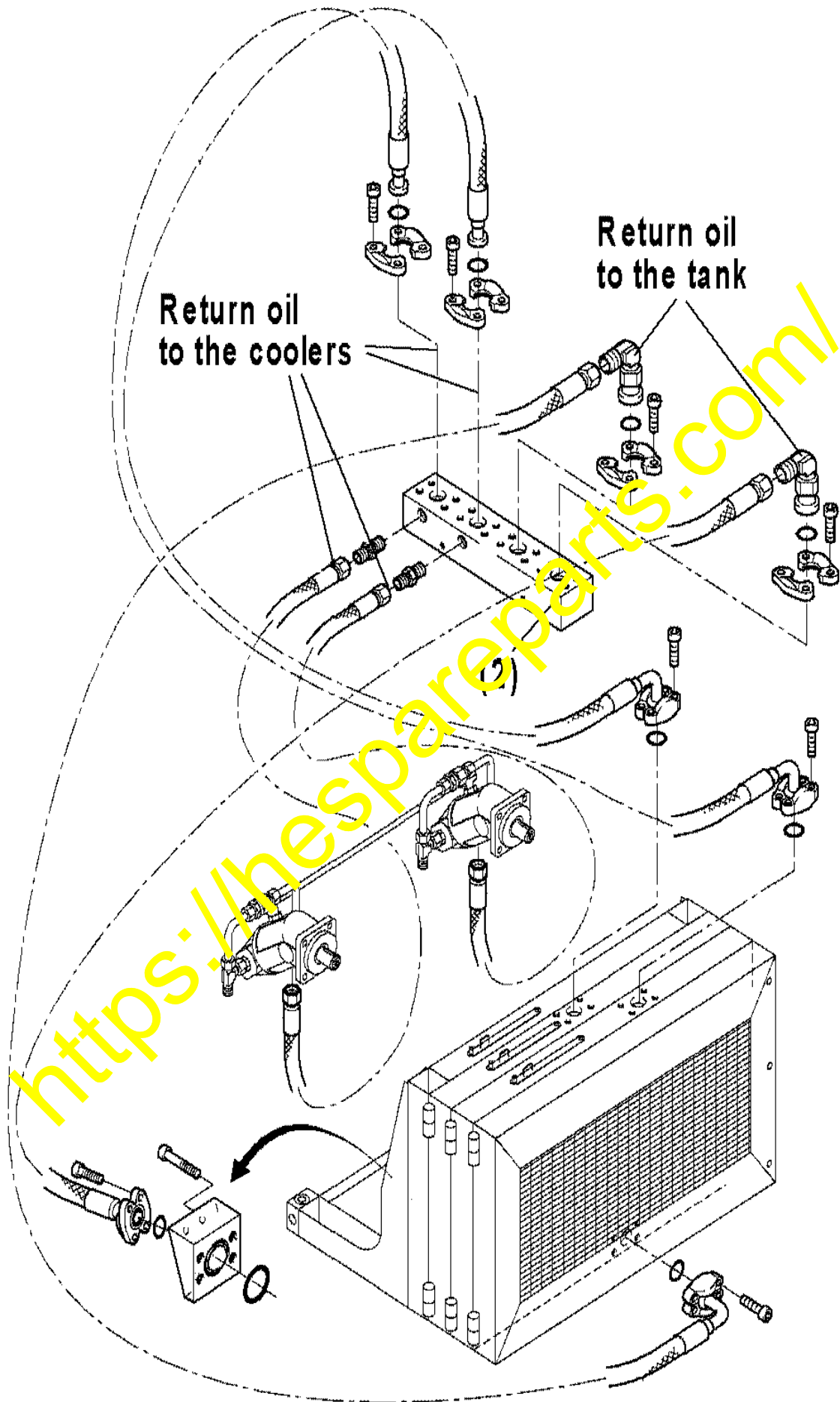

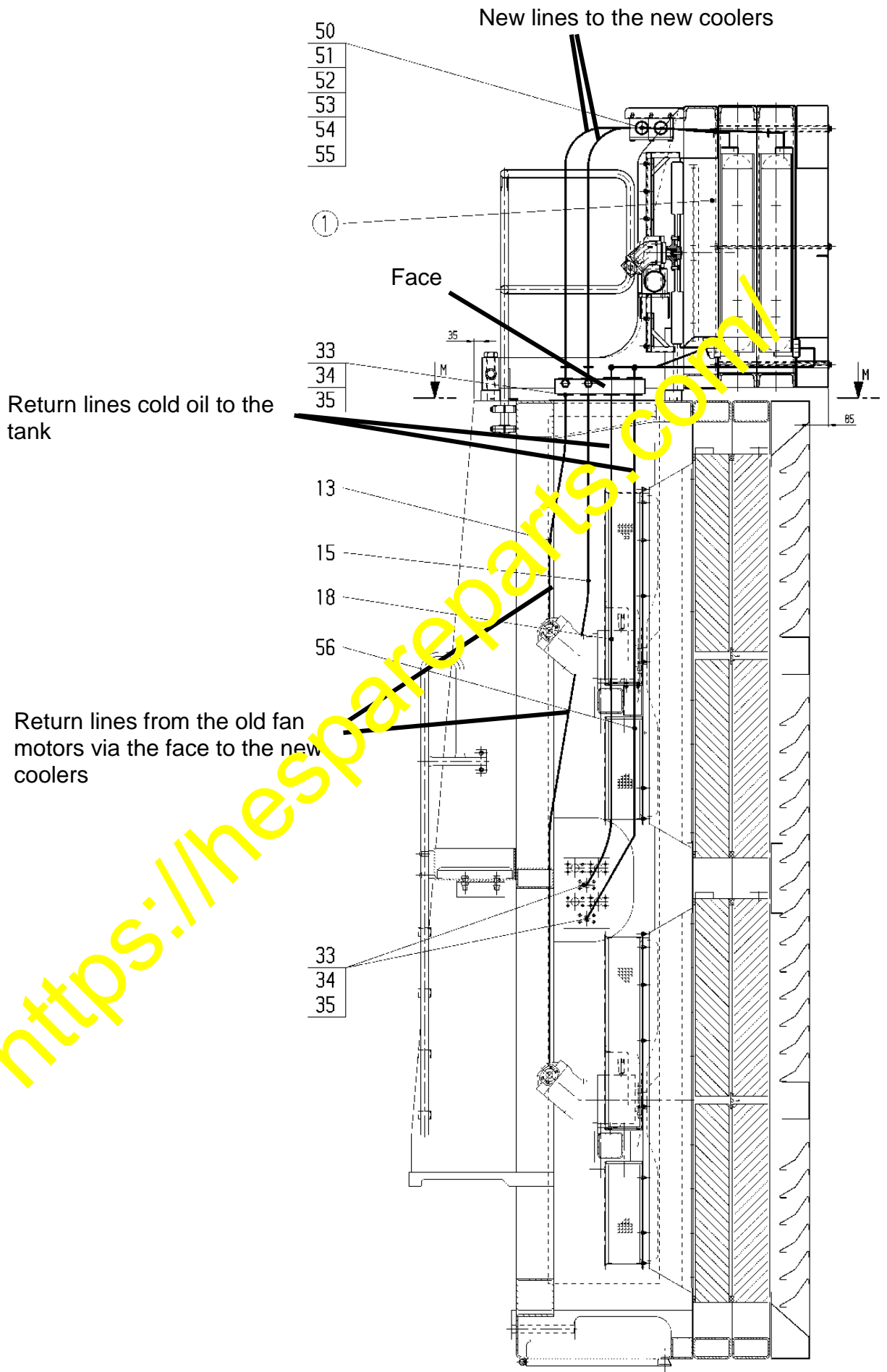

6. Completion of installation

1. Fix the hoses (10 and 11) – pressure lines to the new fan motors – by using the parts (39; 40; 41; 42 and 43).
2. Fix the hose (12) – leak oil line from the new fan motors to the tank – by using the parts (57; 58; 59 and 60).
3. Weld on 4 plates for ladder (23) and 8 plates for rail (22) as shown below.
4. Use the new railing as template.

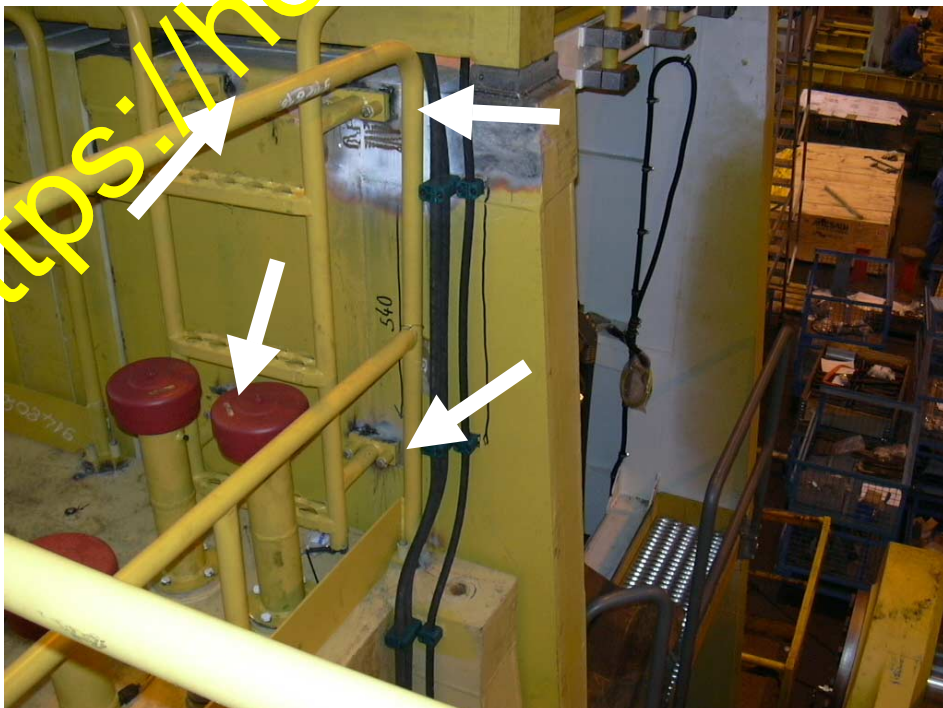
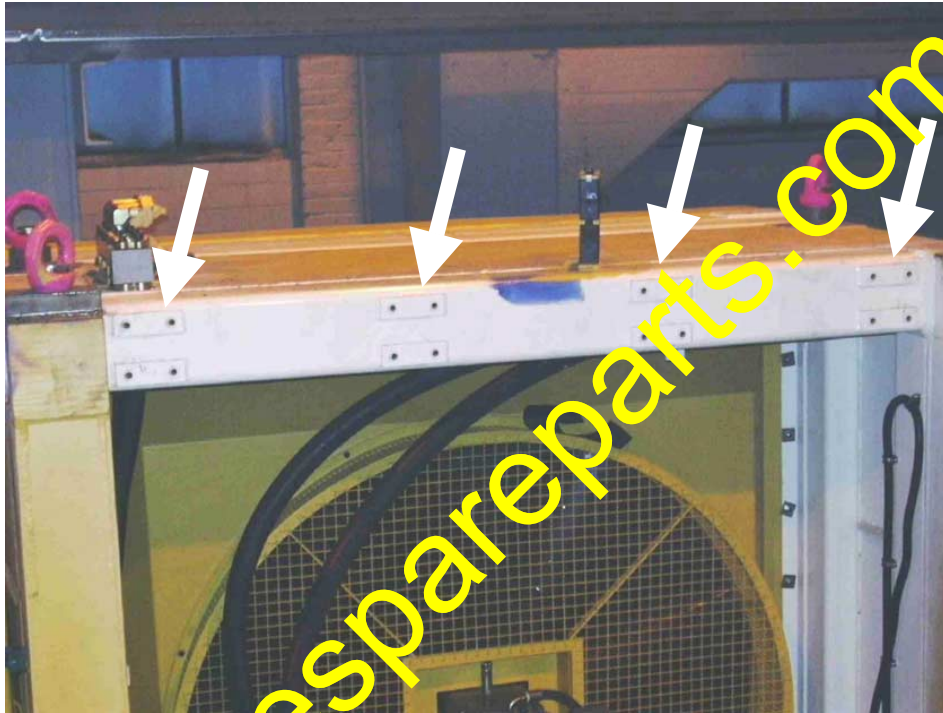

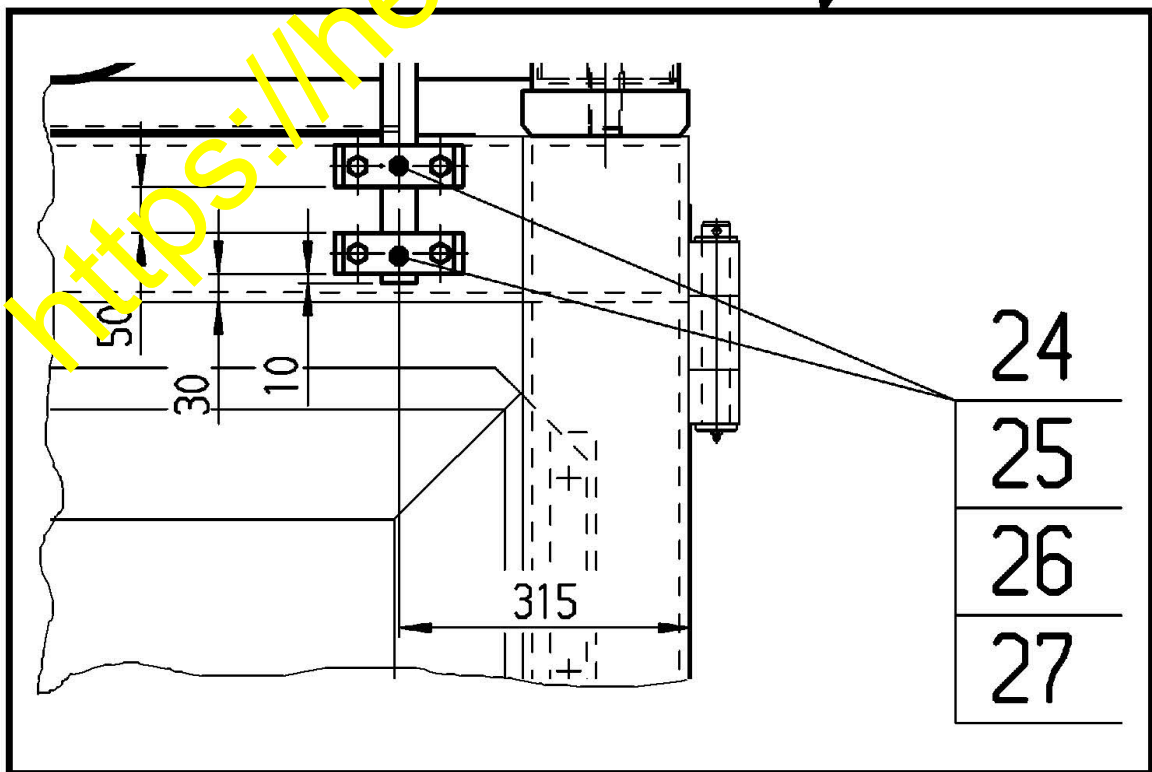
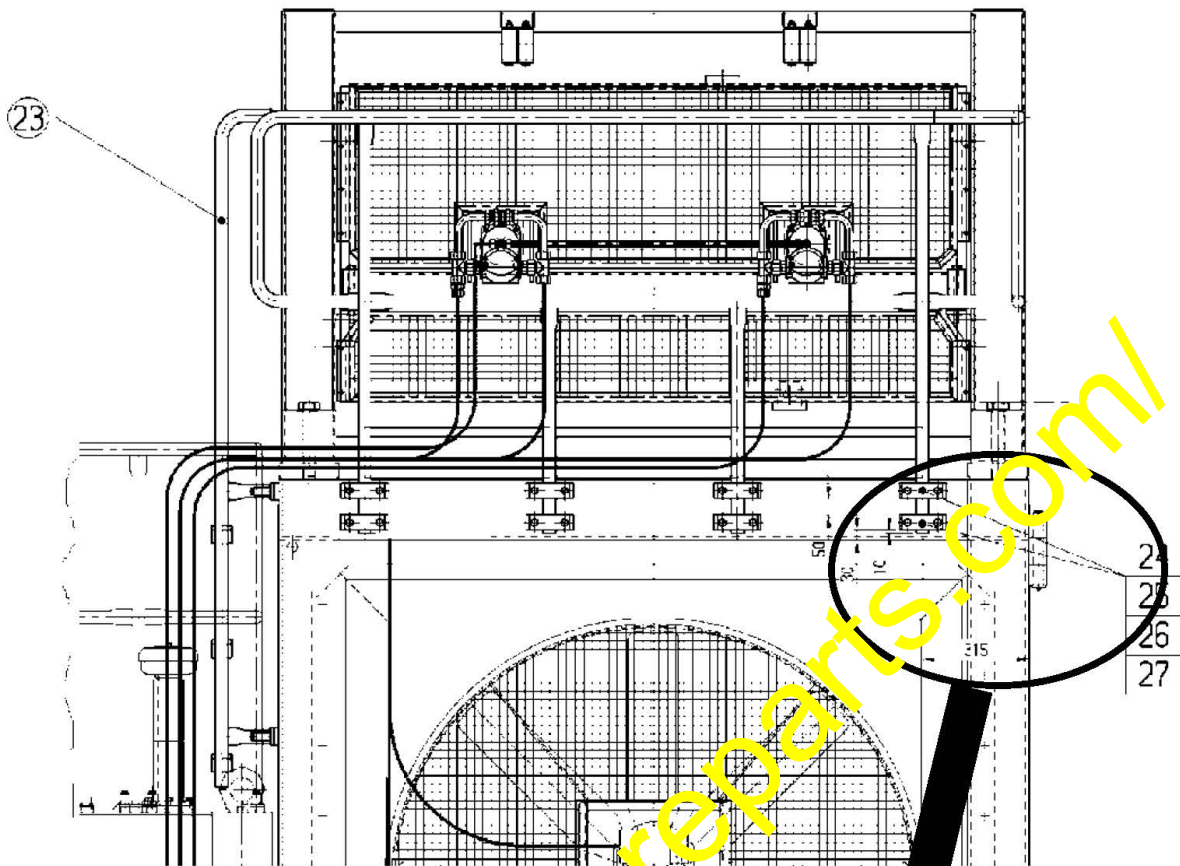

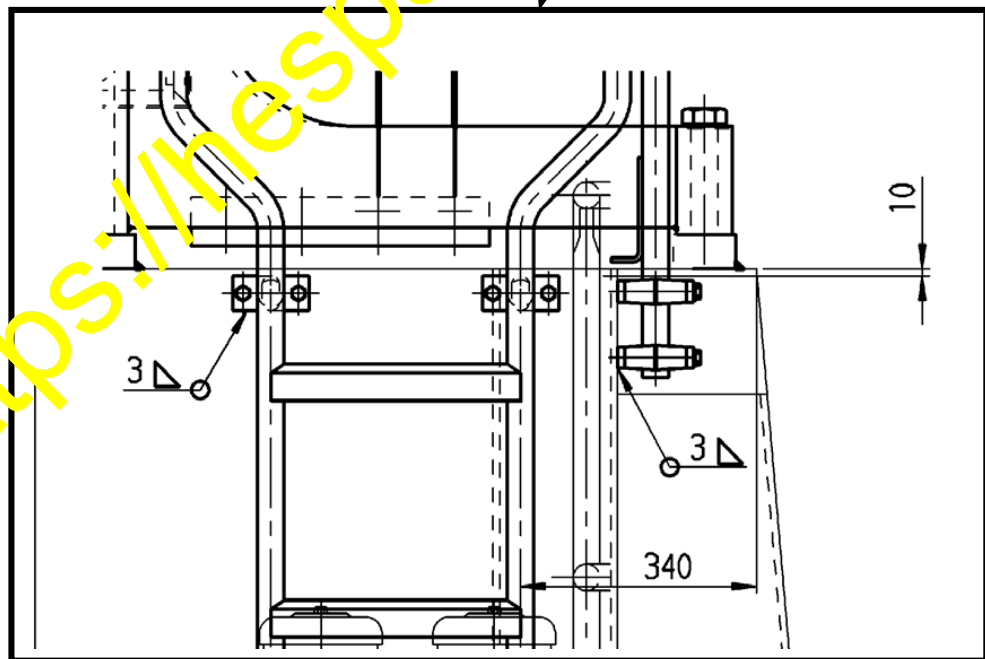
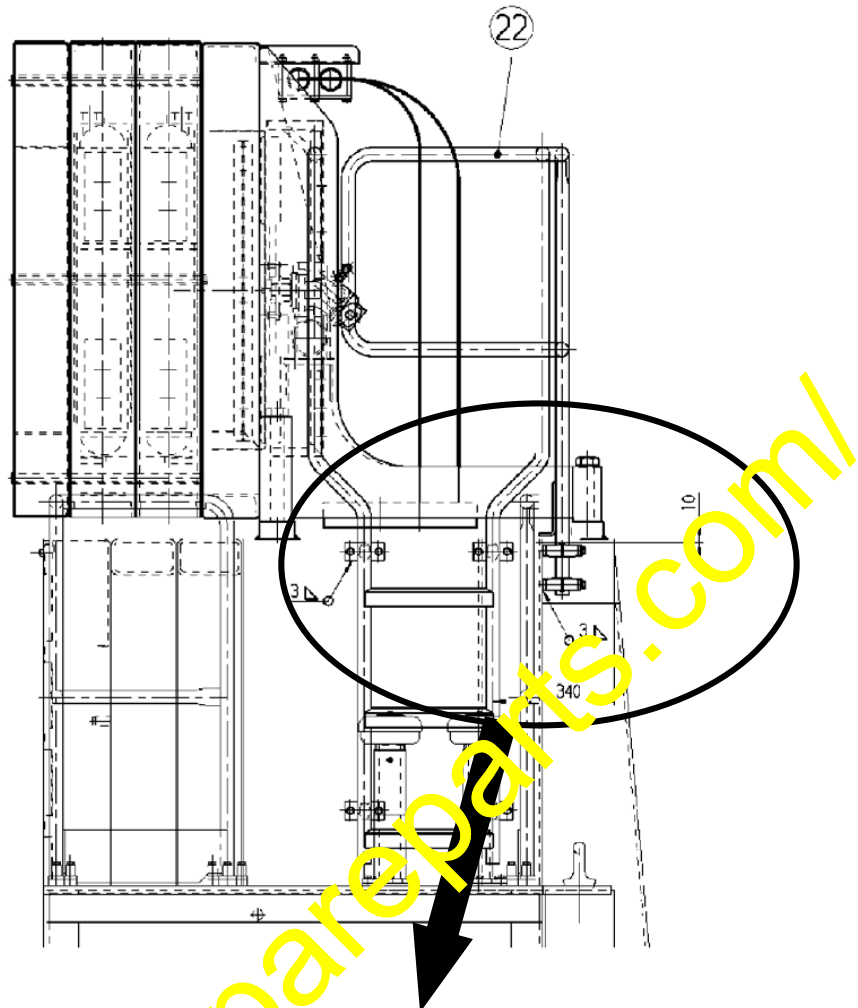

- **Final works: Refill the hydraulic tank; bleed the hydraulic system and check in the end the hydraulic oil level at the tank.**