

PARTS & SERVICE NEWS

REF NO.

AH03524

DATE

22nd July 2003

(C) Page 1 of 3

SUBJECT: Swing gear**PURPOSE:** Increasing the lifetime of the parking brake**APPLICATION:** PC8000-1; PC4000-6; PC3000-1; H 255S; H255A; H455S; H485;
H655S**FAILURE CODE:** 261CFA**DESCRIPTION:****Modification of these swing gears:****GFB 174E 9012, part No. 654 454 40 and****GFB 174E 9015, part No. 898 100 40****Required parts:** 2 plugs, part No. 331 322 99**Removed parts:** 2 radial shaft seal rings (1);
Fittings (5 and 7);
Brake bleeding unit (6).

1. Remove the hoses from the hydraulic motor and the parking brake and plug the lines.
2. Drain the oil of the motor chamber and the brake (refer to Maintenance Manual).
3. Remove the hydraulic motor.
4. Remove the brakeassy. after removing the 12 bolts (1).
5. Remove the brake bleeding unit (6) and plug the hole (not more installed).
6. Remove the seal rings (4) and dispose.
7. Remove the fittings (5; 7) and plug the hole.
8. Remove the 4 bolts (2) and pull off the flange (3) for drilling in a workshop.
9. Drill 6 bores (8) dia.30 mm according drawing page 3.
10. Reinstall the drilled flange.
11. Reinstall the parking brake, the hydraulic motor and reconnect all hoses.
12. Top up the motor chamber oil according to Maintenance Manual.



- **After modification mark the gear with a bench mark letter "a" behind the gear number.**
- **Please inform our Service Department.**

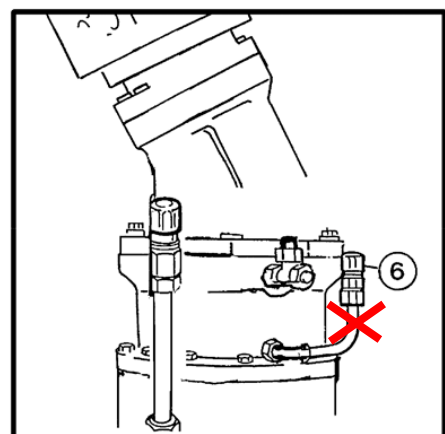
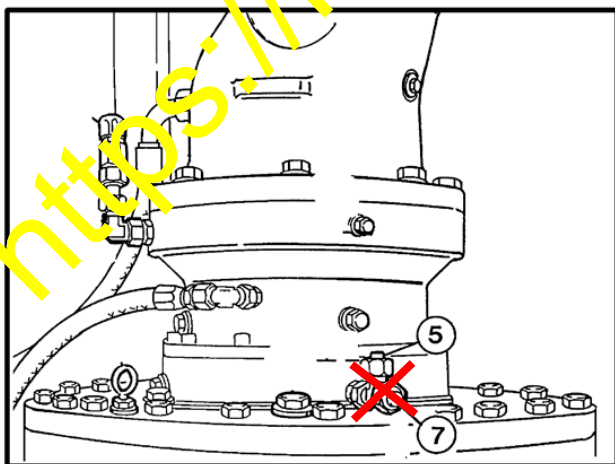
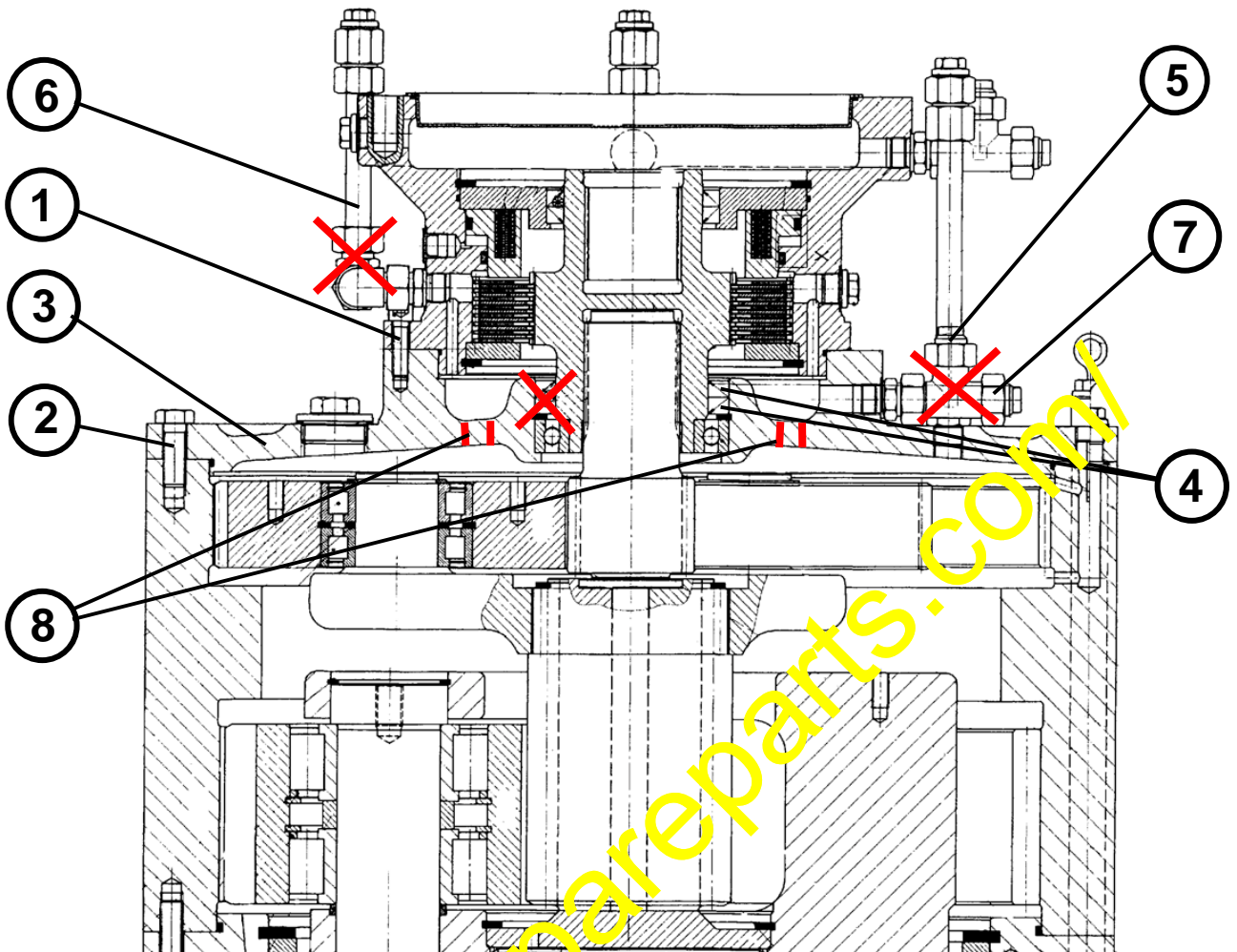

Flange

