

PARTS & SERVICE NEWS

Ref.no.	AH04005
Date.	05.07.2004

(C)

Page 1 of 1

- Subject:** Modification procedure for engine front cover gasket on 140 engine series
- Purpose:** To introduce modification procedure to repair the front cover gasket of the 140 Series engine in case of repair
- Application:** WA500-3H S/N: H20051 up to H20307; H20312; H20316
- Failure code:** A239AA
- Description:** Introduction
Since there is a possibility of occurrence of oil leakage from the front cover gasket of the engine on WA500-3H, make the modification introduced in this Service News to prevent the above mentioned oil leakage.
- Spare parts:**

Pos.	Part name	P/N current	P/N new	Qty.
1	Gasket	6217-21-3250	6217-21-3251	1

Details of the modification

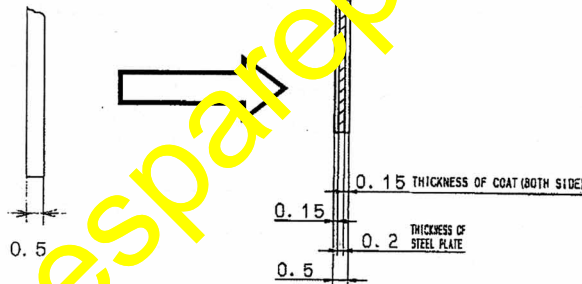

This gasket has been changed to a new gasket containing iron plate to improve the tensile strength.

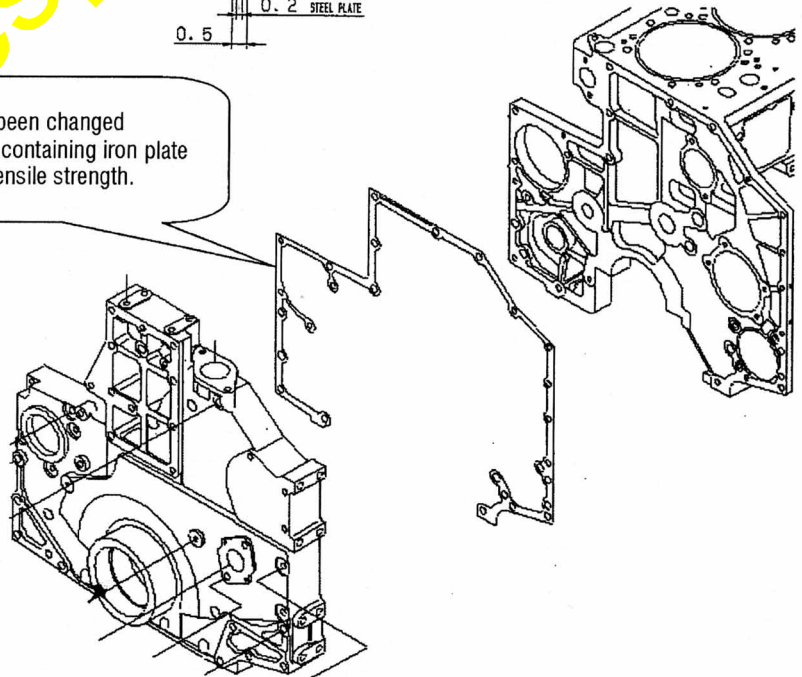

Modification procedure
Carry out this modification work referring to the Shop Manual.