

PARTS & SERVICE NEWS

REF NO.

AH04511

DATE

July 2, 2004

Page 1 of 4

SUBJECT: Swing gear GFB 174E 9012**PURPOSE:** Increasing of the lifetime by using of new kind of bearings (C2)**APPLICATION:** H 485 (12004; 12008; 12023; 12024);
H 655S (12025-027; 12031-32; 12034);
PC8000-1 (12028-29; 12033; 12035-36)**FAILURE CODE:** 261CDJ**DESCRIPTION:**

- During a complete overhaul of the swing gear the bearings (21 and 62 – refer to drawing next page) should be changed to the new type (C2).
- Refer also Service Bulletin AH03524 – “Modification of the swing brake”.

For using new roller bearings (21; 62) the Sealing Cover (13) and the Axle Tube (03) have to be remachined according to the drawings on pages 3 and 4.

GFB 174E 9012 (PN 654 454 40)

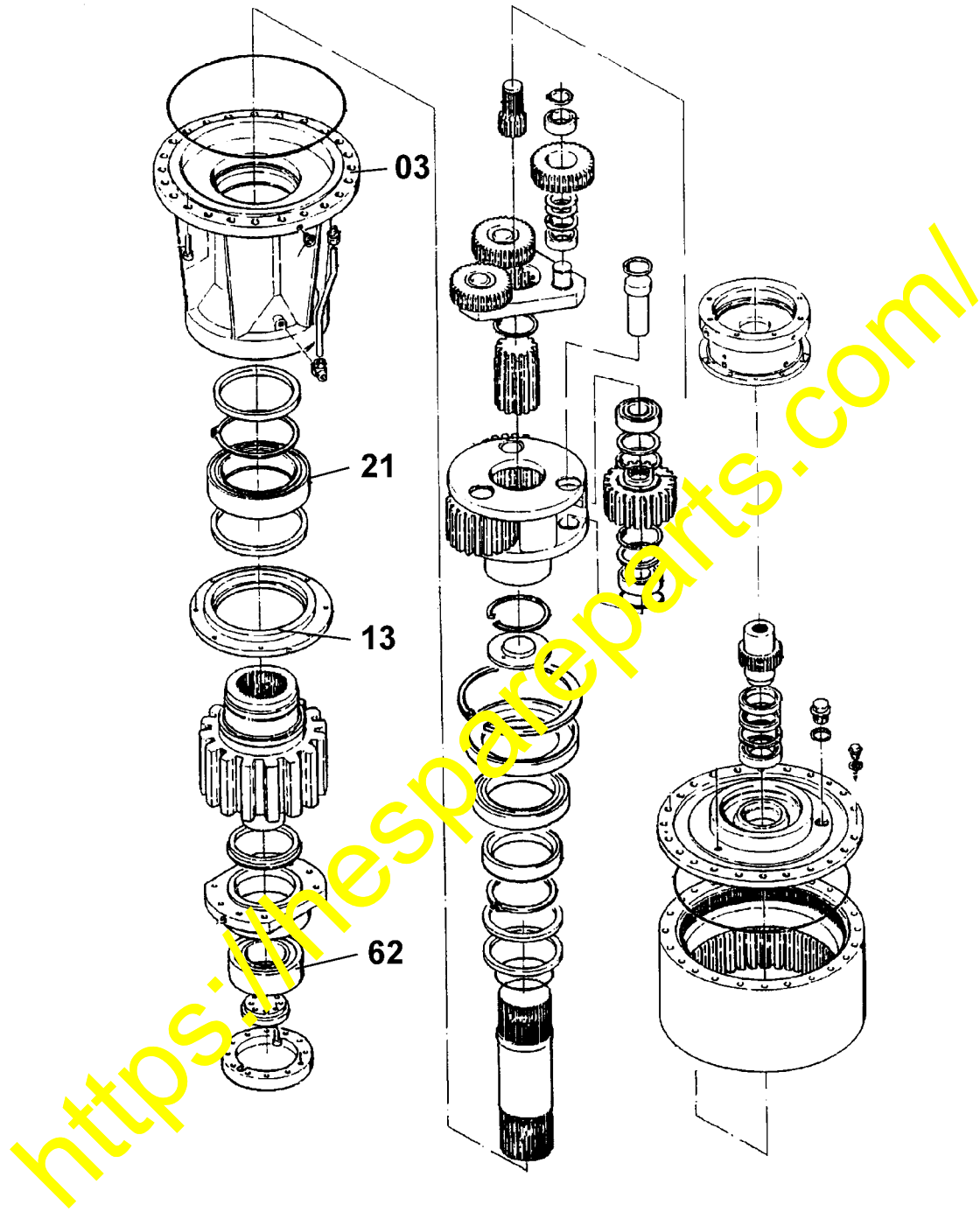
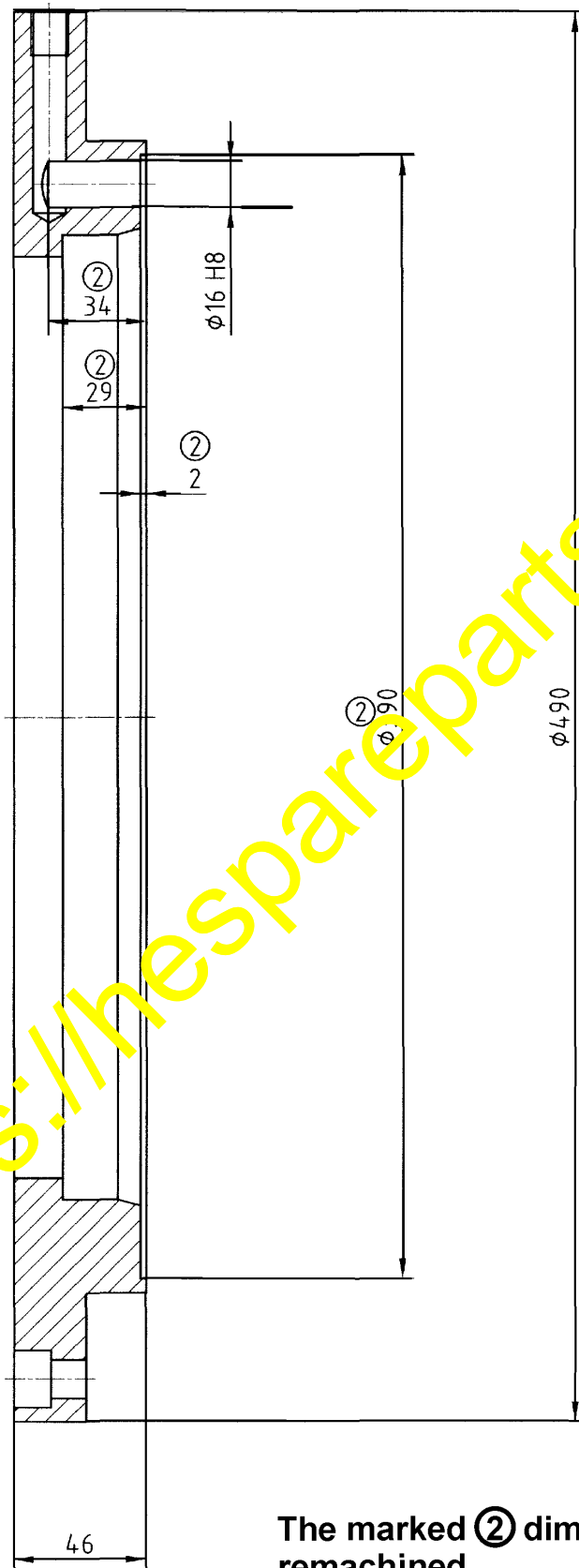

Fig.	PN	Qty.	Description	PN (new)
03	757 767 73	1	Axle tube	757 767 73*
13	757 249 73	1	Sealing cover	757 249 73*
21	507 745 98	1	Roller bearing	517 388 98
62	507 746 98	1	Roller bearing	517 389 98

* modified

Sealing cover Pos. 13



The marked ② dimensions have to be remachined

Axle tube Pos. 03

675±0.5 (Dimension have to be remachined)

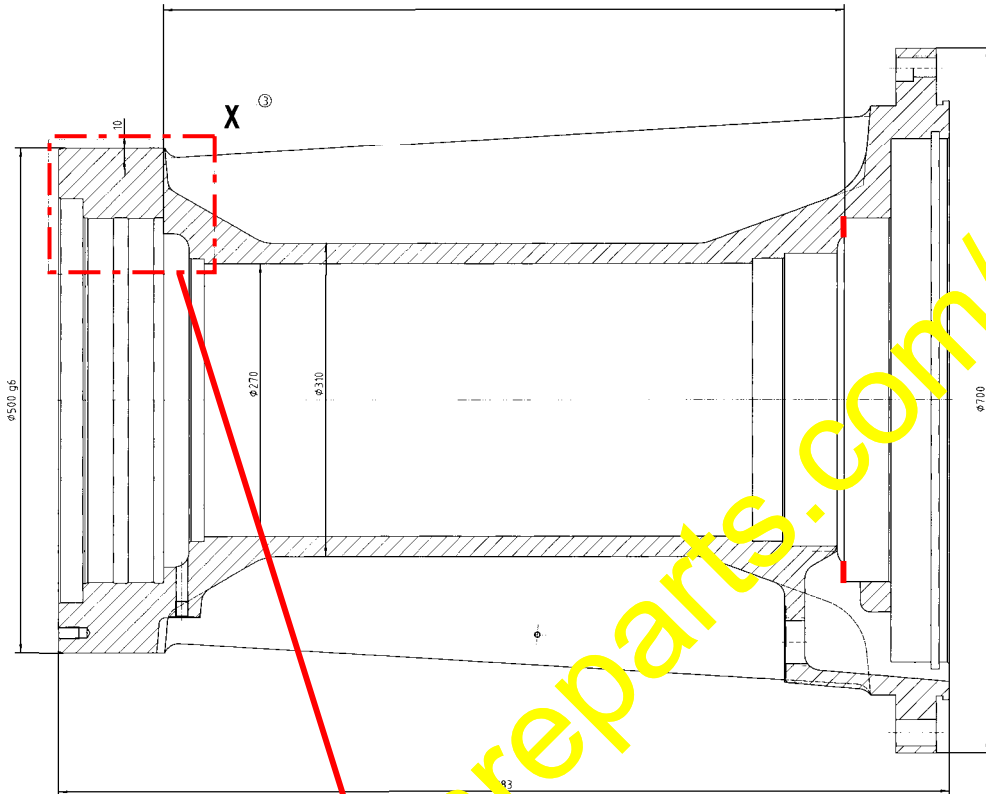

Detail X ③

All dimensions have to be checked and if necessary remachined ($\sqrt{Rz 3}$)

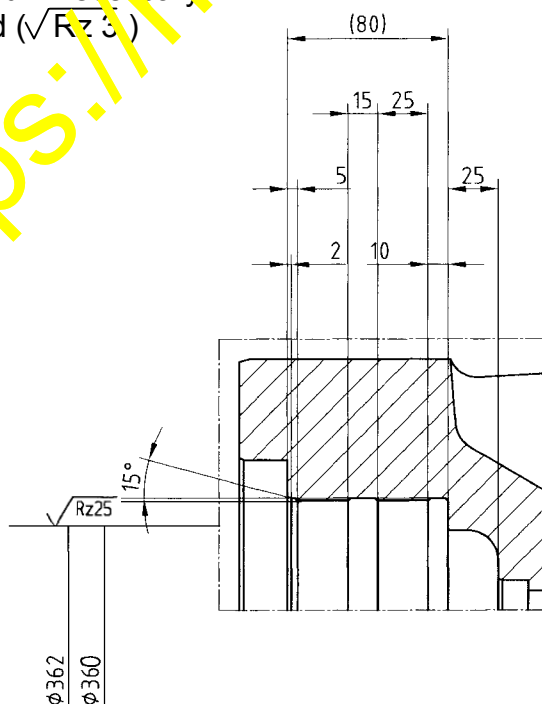

Dimension	Tolerance
2	± 0.1
5	±0.1
10	±0.2
15	±0.2
25	±0.2
80	±0.3
360	±0.5
362	±0.5