

# PARTS & SERVICE NEWS

REF NO.	AT01074A
DATE	Aug. 23, 2002

Page 1 of 6

This PARTS & SERVICE NEWS supersedes the previous issue No. AT01074 dated Jun. 5, 2001 which should be discarded.

**SUBJECT:** INTRODUCTION OF WEAR PREVENTION SPRING FOR P. BRAKE PAD ON WA700/800/900-3/WD900-3

**PURPOSE:** To introduce newly prepared caliper return springs for use on the parking brake on the WA700/800/900-3/WD900-3

**APPLICATION:** WA700-3 Wheel Loaders, Serial Nos. 50001 thru 50045  
 WA800-3 Wheel Loaders, Serial Nos. 50001 thru 50021  
 WA900-3 Wheel Loaders, Serial Nos. 50001 thru 50011  
 WD900-3 Wheel Loaders, Serial Nos. 50001 thru 50001

**FAILURE CODE:** 2F14CC

## DESCRIPTION:

### 1-1. Introduction

If a lot of earth sticks to the parking brake, it serves as an abrasive to accelerate wear on the brake pads, which in turn necessitates frequent adjustment of the parking brake clearance. This Parts and Service News introduces newly prepared springs for the parking brake on above models which work to deter wear on the brake pads even when the earth sticks to them and how to install them.

### 1-2. Revised places:

1 place 	Aug. 23, 2002	The error in writing of Part No. is corrected.
---	---------------	--

## 2. List of parts

Part No.	Part Name	Q'ty	Remarks
<WA700-3>			
426-32-25371 (426-22-25321)	Plate (Plate)	2 (2)	} Parts common with WA600-3
426-32-25342	Spring	2	
426-32-25352	Spring	2	
426-32-25362	Bracket	2	
01010-81260	Bolt	4	
01643-31232	Washer	4	
<WA800-3, WA900-3, WD900-3>			
426-32-25371 (426-22-25321)	Plate (Plate)	4 (4)	} Parts common with WA600-3
426-32-25342	Spring	4	
426-32-25352	Spring	4	
 426-32- <del>25363</del> <sup>25362</sup>	Bracket	4	
01010-81260	Bolt	8	
01643-31232	Washer	8	
427-62-12253 (427-62-12252)	Tube (Tube)	1 (1)	} Replacement parts for modification
07000-F3048 (07000-F3048)	O-ring (O-ring)	1 (1)	
07000-F3038 (07000-F3028)	O-ring (O-ring)	1 (1)	

3. Contents of the modification

Additional caliper-returning springs are to be installed. (See the drawings below which are for Model WA700-3. The models WA800-3, WA900-3 and WD900-3 carry two sets of calipers, on right and left.)

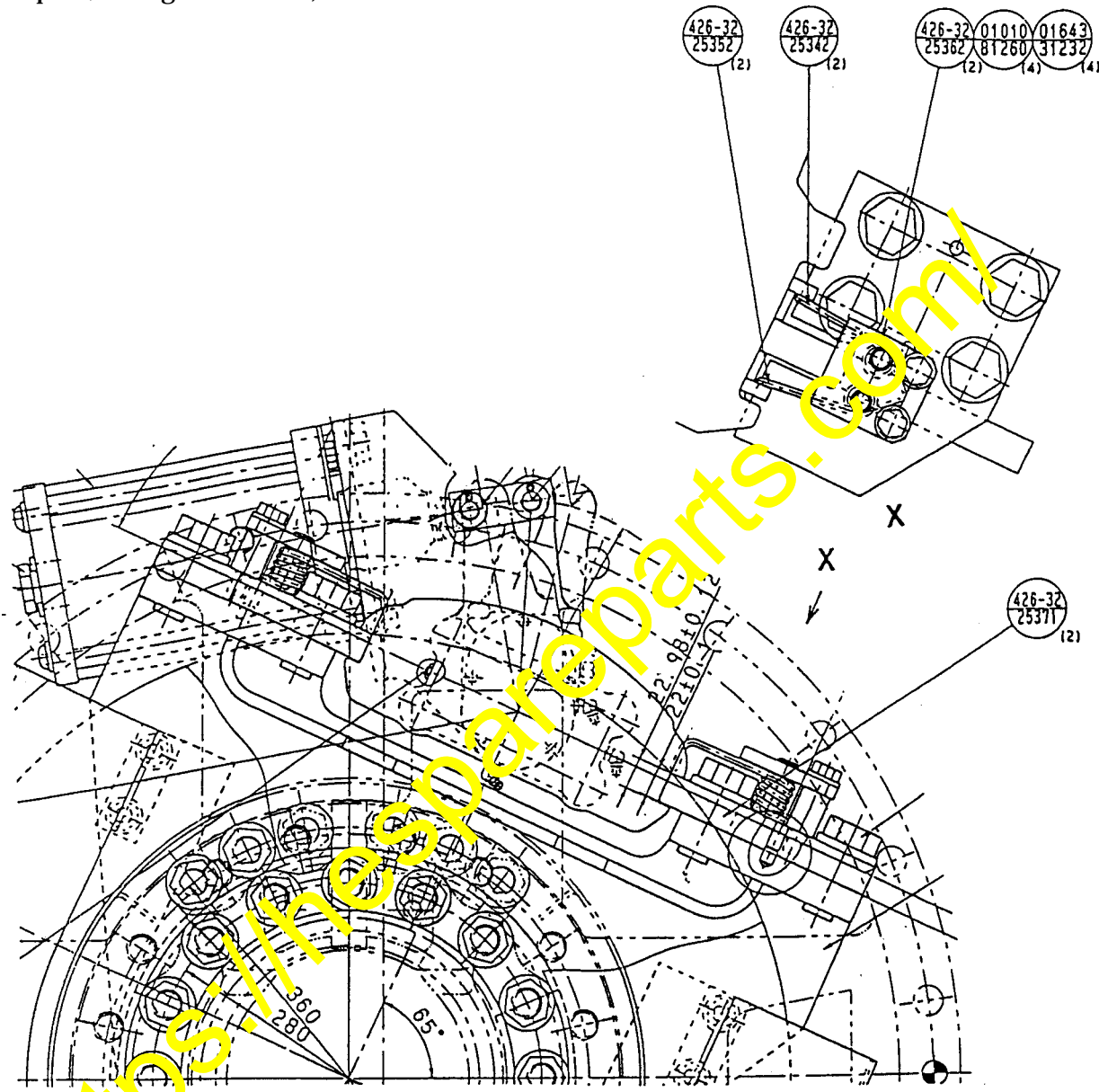

< Conventional Type >

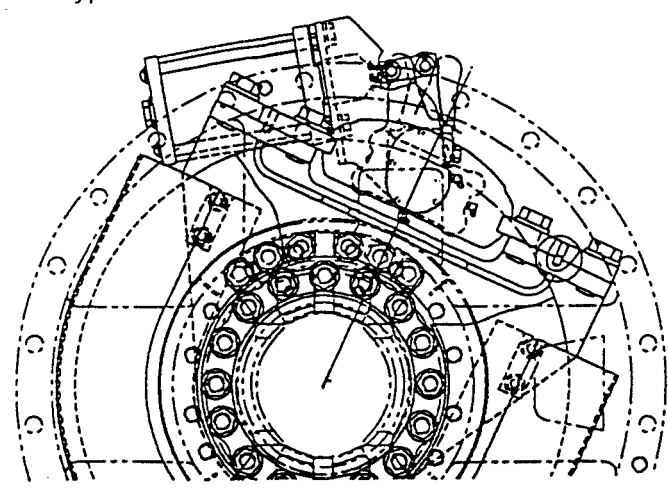

Steps for Installation

- Dismantle the parking brake assembly.

**⚠** Park the machine on the flat and solid ground, then lower the work equipment to the ground, and apply chocks to the wheels.

**⚠** Disconnect the negative (-) terminal of the battery pack.

1. Remove disc plate cover (1).
2. Detach propeller shaft (2). ※1

 Drive Shaft: 112 kg (WA700)  
173 kg [WA800, WA900]  
WD900

3. Turn adjusting bolt (3) counterclockwise to increase the clearance between the pad and the disc. ※2

4. Pull out connecting pin (4).
5. Detach hose (5).
6. Detach spring cylinder (6).
7. Remove plate (7). ※3

★ Keep the caliper fixed.  
★ Two knock pins are used. Remove them after slightly lifting up the caliper.

8. Remove pad (8).
9. Dismantle caliper assembly (9).

 Caliper Assembly Weight: 40 kg

10. Loosen the disc securing bolts (10) and take off disc (11). ※4
11. Loosen the bracket securing bolts (12) and take off the bracket (13). ※5
12. Loosen the plate securing bolts (14) and take off the plate (7). ※3

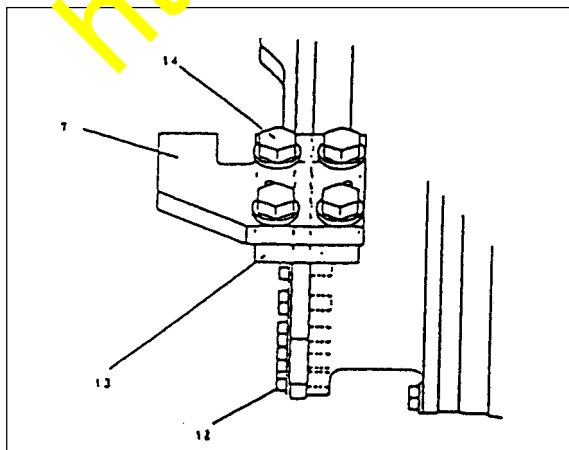
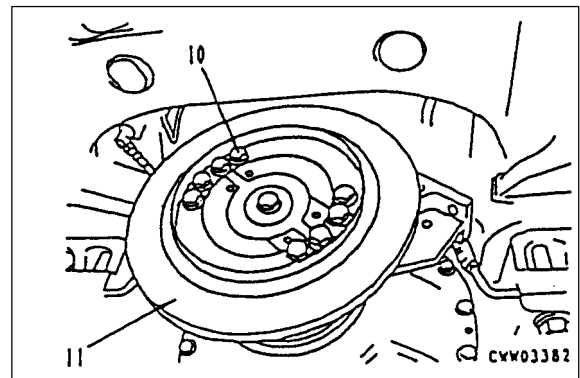
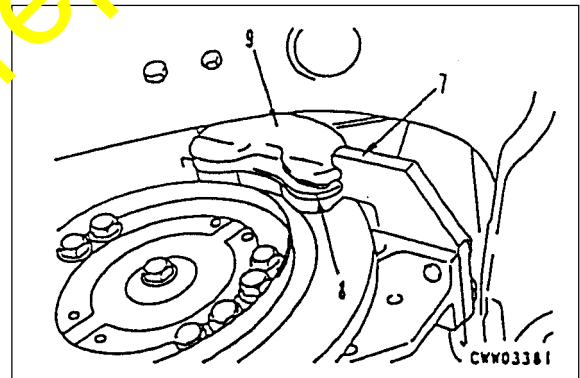
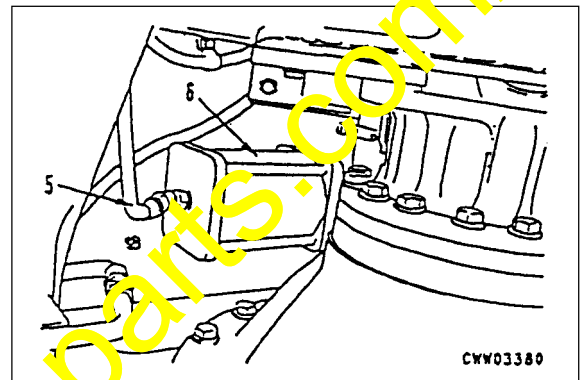
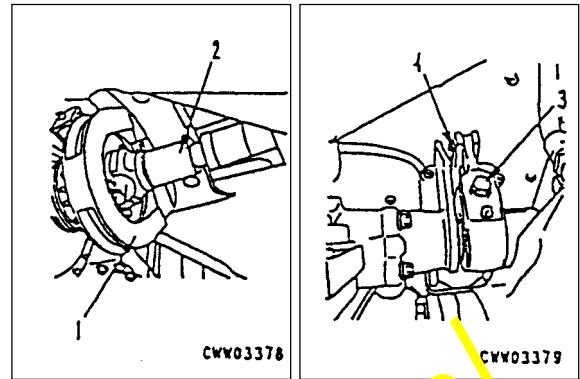

## Steps for Installation

Mount the parking brake assembly.

- The parking brake assembly can be mounted exactly in the reverse order to the dismantling.
- ★ When mounting the parking brake assembly, make sure to install the plate (16) incorporating springs (15), in lieu of plate (7).

 Securing Bolts: 98 – 122 Nm {10 – 12.5 kgm}

※ 1

Securing Bolts: 157 – 196 Nm {16 – 20 kgm}

※ 2

★ For the inspection and adjustment, see the section of "Inspection and Adjustment of Parking Brake Assembly"

※ 3

 Securing Bolts: Adhesive Compound (LT-2)

 Securing Bolts: 824.0 – 1030.0 Nm {84.0 – 105.0 kgm}

※ 4

 Securing Bolts: Adhesive Compound (LT-2)

 Securing Bolts: 490.0 – 608.0 Nm {50 – 62 kgm}

※ 5

 Securing Bolts: Adhesive Compound (LT-2)

 Securing Bolts: 245 – 309 Nm {25.0 – 31.5 kgm}

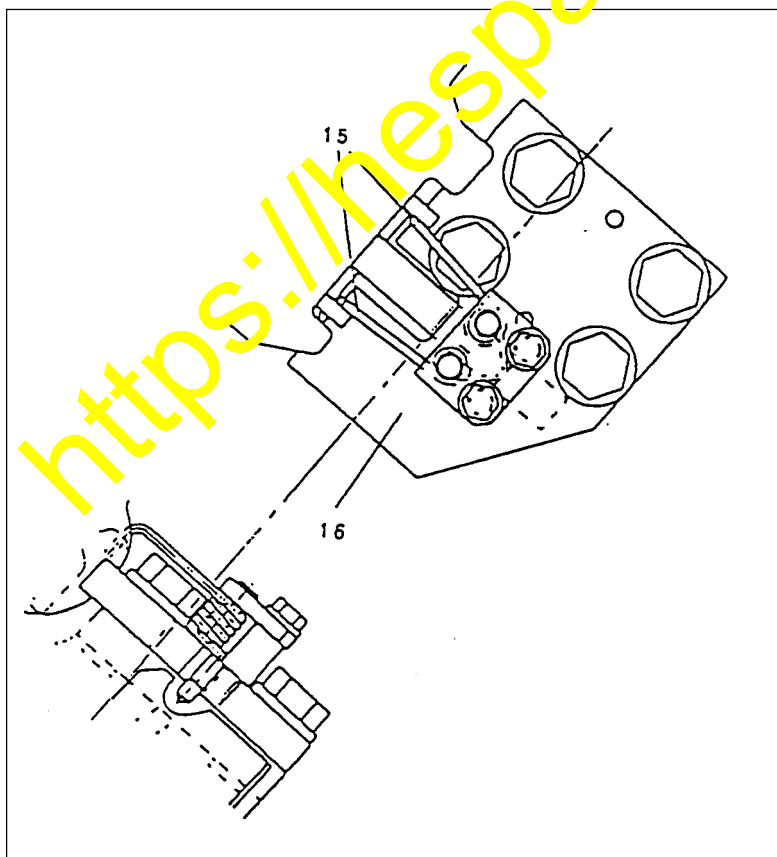

- Air Bleeding  
Bleed air remained in the parking brake circuit, referring to the clause of "Air Bleeding in Each Part" of the Inspection and Adjustment section.

### Steps for Installation

With WA800-3, WA900-3 and WD900-3 models, replace the current steering piping (tube) with new one prior to the installation of the modified parts for reason of preventing interference. This replacement is not required of WA700-3 model.

