

PARTS & SERVICE NEWS

REF NO.	AT02023
DATE	Feb. 8, 2002

Page 1 of 11

SUBJECT: REPAIR OF 102ENGINE EXCESSIVE OIL CONSUMPTION

PURPOSE: To introduce modification procedure to repair when excessive engine oil consumption is experienced with the ϕ 102 series engines

APPLICATION: All machines mounting ϕ 102 Engine, Serial Nos. are referred to pages 7 thru 11.

FAILURE CODE: A000Z9

DESCRIPTION:

1. Introduction

When excessive engine oil consumption is experienced with the ϕ 102 series engines, implement the modification being introduced in this Service News to suppress the engine oil consumption.

<https://hespareparts.com/>

2. List of parts
(4D102E-1, S4D102E-1)

Part No.	Part Name	Purpose of part	Q'ty	Remarks
6735-31-2111 (6735-31-2110)	Piston (Piston)	} Replacement	4 (4)	Standard
6738-31-2031 (6732-31-2300)	Piston ring ass'y (Piston ring ass'y)		4 (4)	Standard
6732-K1-1100 (6732-K1-1100)	Gasket kit (Gasket kit)		1 (1)	
6733-21-5520 (6733-21-5520)	Gasket (Gasket)		1 (1)	Consumable parts (For the suction tube)
6736-11-5590 (6736-11-5590)	Gasket (Gasket)		1 (1)	Consumable parts (For the outlet port of exhaust manifold) 4D102E-1
6150-11-5710 (6150-11-5710)	Gasket (Gasket)		1 (1)	Consumable parts (For the inlet port of muffler) D31, 37
07005-00812 (07005-00812)	Gasket (Gasket)		4 (4)	Consumable parts (For the fuel circuit)
07005-01012 (07005-01012)	Gasket (Gasket)		10 (10)	Consumable parts (For the fuel circuit)
07005-01412 (07005-01412)	Gasket (Gasket)		8 (8)	Consumable parts (For the fuel circuit)
6742-01-5157 (6742-01-5157)	Gasket (Gasket)		4 (4)	Consumable parts (For the fuel circuit)
07003-01015 (07003-01015)	Gasket (Gasket)		2 (2)	Consumable parts (For the oil feeding tube to the turbocharger) PC158, CD45
6221-51-8160 (6221-51-8160)	Gasket (Gasket)		1 (1)	Consumable parts (For the oil feeding tube to the turbocharger) PC128-1, PC100, PC120, LC1285, BZ120, BA200, BM2009, BM3618

(SAA4D102E-2)

Part No.	Part Name	Purpose of part	Q'ty	Remarks
6738-31-2111 (6738-31-2110)	Piston (Piston)	Replacement	4 (4)	Standard
6738-31-2031 (6738-31-2030)	Piston ring ass'y (Piston ring ass'y)		4 (4)	Standard
6732-K1-1100	Gasket kit		1	
6733-21-5520 (6733-21-5520)	Gasket (Gasket)		1 (1)	Consumable parts (For the suction tube)
07005-01012 (07005-01012)	Gasket (Gasket)		4 (4)	Consumable parts (For the fuel circuit)
07005-01412 (07005-01412)	Gasket (Gasket)		8 (8)	Consumable parts (For the fuel circuit)
6736-11-5820 (6736-11-5820)	Gasket (Gasket)		4 (4)	Consumable parts (For the exhaust manifold)

(6D102E-1, S6D102E-1, SA6D102E-1)

Part No.	Part Name	Purpose of part	Q'ty	Remarks
6735-31-2111 (6735-31-2110)	Piston (Piston)	Replacement	6 (6)	Standard
6738-31-2031 (6732-31-2300)	Piston ring ass'y (Piston ring ass'y)		6 (6)	Standard
6735-K1-1100	Gasket kit		1	S6D102E-1
6736-K1-1100	Gasket kit		1	SA6D102E-1
6734-K1-1100	Gasket kit		1	FD40, FD50, FD80
6733-21-5520 (6733-21-5520)	Gasket (Gasket)		1 (1)	Consumable parts (For the suction tube)
07005-01012 (07005-01012)	Gasket (Gasket)		4 (4)	Consumable parts (For the fuel circuit)
07005-01412 (07005-01412)	Gasket (Gasket)		10 (10)	Consumable parts (For the fuel circuit)
6735-21-5660 (6735-21-5660)	Gasket (Gasket)		1 (1)	Consumable parts (For the oil pan) D41, CD60

(SAA6D102E-2)

Part No.	Part Name	Purpose of part	Q'ty	Remarks
6738-31-2111 (6738-31-2110)	Piston (Piston)	} Replacement	6 (6)	Standard
6738-31-2031 (6736-31-2030)	Piston ring ass'y (Piston ring ass'y)		6 (6)	Standard
6735-K1-1100	Gasket kit		1	
6733-21-5520 (6733-21-5520)	Gasket (Gasket)		1 (1)	Consumable parts (For the suction tube)
07005-01012 (07005-01012)	Gasket (Gasket)		8 (8)	Consumable parts (For the fuel circuit)
07005-00812 (07005-00812)	Gasket (Gasket)		4 (4)	Consumable parts (For the fuel circuit)
07005-01412 (07005-01412)	Gasket (Gasket)		10 (10)	Consumable parts (For the fuel circuit)
6221-51-8160 (6221-51-8160)	Gasket (Gasket)		1 (1)	Consumable parts (For the oil feeding tube to the turbocharger)

3. Contents of the improvements

3.1 Improvements for already shipped machines

To suppress engine oil consumption, the following improvements have been made.

- (1) Oil return holes have been added to the piston.
- (2) The keystone angle tolerance for the top ring has been changed.

<Piston>

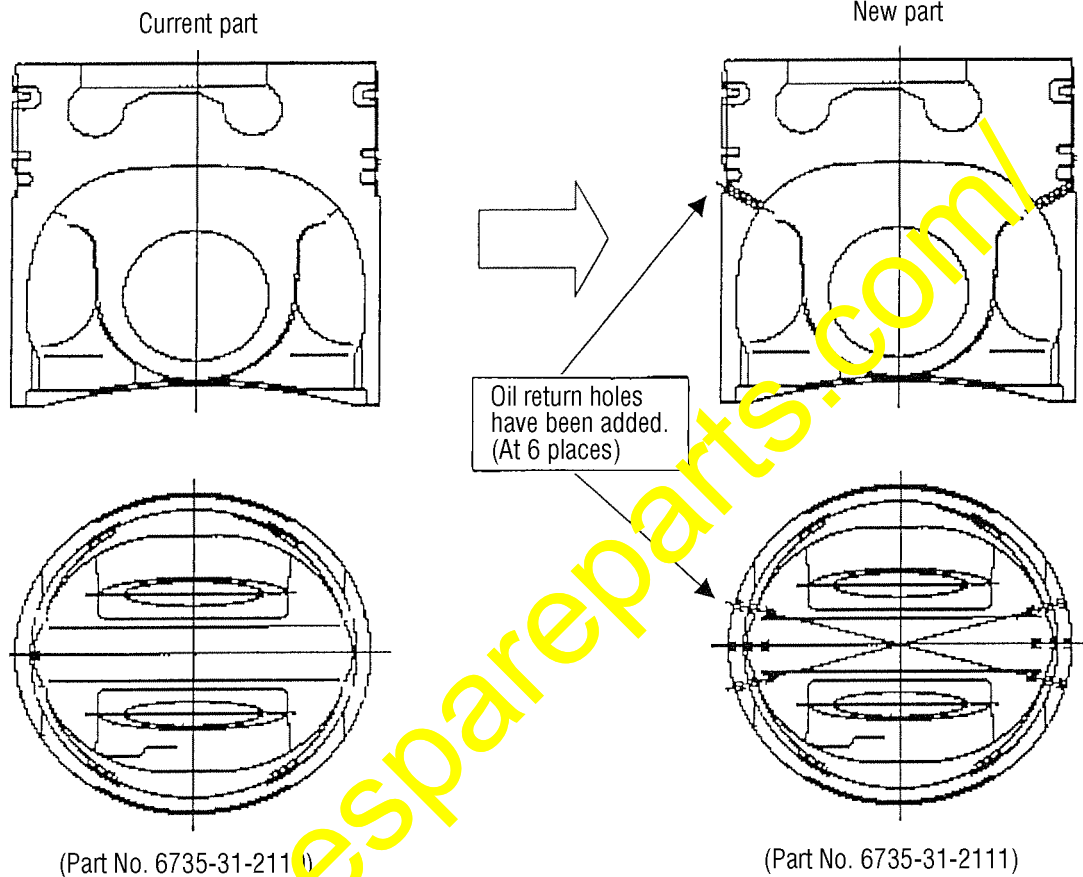

<Top ring>

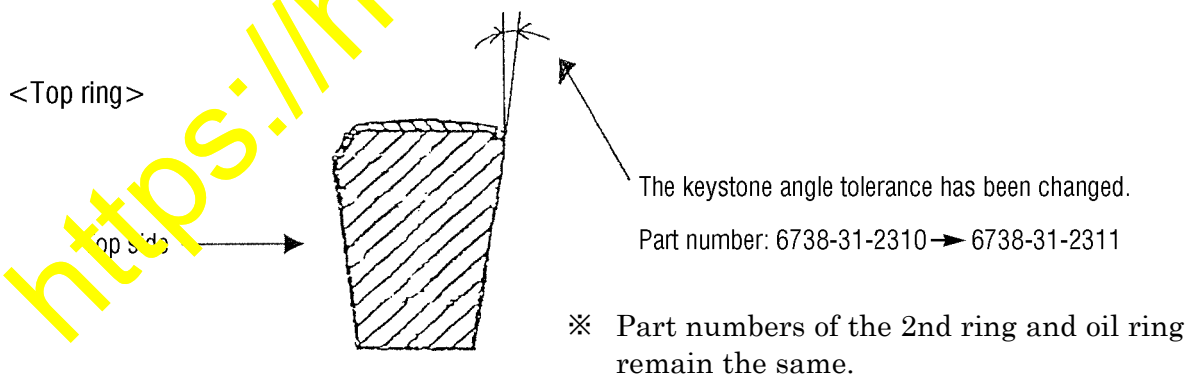

Part numbers of the oversized parts of the piston and the piston ring ass'y are being introduced on the next page.

3.2 Improvements for factory shipment machines

In addition to the improvements of Items (1) and (2) in Section 3.1 on the preceding page, the H – L distance of the oil level gauge has been changed for some machine models to prolong the oil refilling interval. (Oil quantity required when making oil change: 24.0 L → 25.0 L)

Machine models with which the H – L distance of the oil level gauge has been changed are those models marked * on pages 8 thru 11.

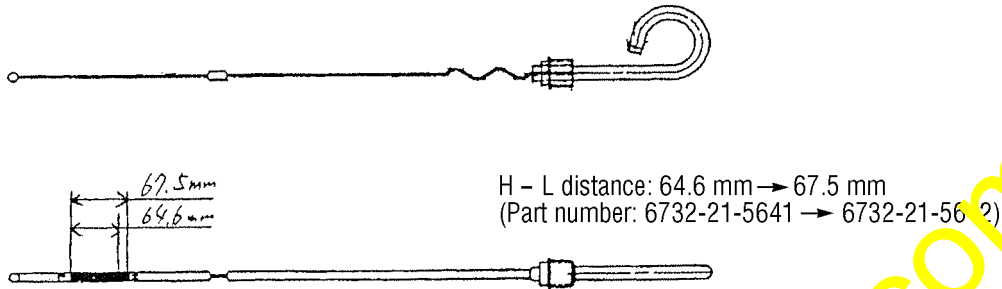

Introduction of part numbers of the oversized parts

(1) (S)4D102E-1 and (S)(A)6D102E-1

		New parts	Current parts
Oversized by 0.5 mm	Piston	6735-38-2121	6735-38-2120
	Piston ring ass'y	6738-39-2031	6732-39-2300
Oversized by 1.0 mm	Piston	6735-38-2131	6735-38-2130
	Piston ring ass'y	6738-38-2031	6732-38-2300

(2) SAA4D102E-2 and SAA6D102E-2

		New parts	Current parts
Oversized by 0.5 mm	Piston	6738-39-2111	6738-39-2110
	Piston ring ass'y	6738-39-2031	6738-39-2030
Oversized by 1.0 mm	Piston	6738-38-2111	6738-38-2110
	Piston ring ass'y	6738-38-2031	6738-38-2030

4. Modification procedure

- (1) Replace the piston and piston ring referring to the Shop Manual.
- (2) After finishing replacement of the above parts, check and confirm that oil leakage is not occurring from the engine.

List of serial numbers of the applicable machines and engines

1. (S)4D102E-1

No.	Machine models	Already shipped machines	Already modified factory shipment machines		Remarks
		Serial numbers of the machines	Serial numbers of the machines	Implementation starting from	
		Serial numbers of the engines	Serial numbers of the engines		
1	PC100-6	(#42285 – #46945) #26200001 – #26293653	(#46946 –) #26293654 –	1/10	
2	PC100-JK-6	— #26200001 – #26292886	—	From the next order	For KI
3	PC100N-6	(#40001 – #46945) #26200001 – #26292855		From the next order	
4	PC120-6	(#60001 – #65669) #26200001 – #26293653	(#65670 –) #26293654 –	1/10	
5	PC130-6	(#50001 – #52887) #26200001 – #26293653	(#52888 –) #26293654 –	1/10	
6	PC128UU-1 PC128US-1	(#1001 – #4045) #26200001 – #26262167		From the next order	
7	PC128UU-2 PC128US-2	(#7001 – #7800) #26200001 – #26293708	(#7801 –) #26293709 –	1/10	
8	PC138US-1 PC138US-2	(#2001 – #2900) #26200001 – #26293708	(#2901 –) #26293709 –	1/10	
9	PC158US-2	(#10001 – #100162) #26200001 – #26291352		From the next order	
10	PW128UU-1	(#1001 – #1289) #26200001 – #26292476		From the next order	
11	D31-20	(#40001 – #49401) #26200001 – #26293688	(#49402 –) #26293689 –	1/10	
12	D37-5	(#4001 – #4048) #26200001 – #26292502	(#4049 –) #26294215 –	1/25	
13	GD305A-3	(#8001 – #8035) #26200001 – #26292853		From the next order	
14	GD355A-3	(#7001 – #7052) #26200001 – #26293438		From the next order	
15	WA100-3	(#53001 – #64328) #26200001 – #26293674	(#64329 –) #26293675 –	1/10	
16	WA120-3	(#53001 – #54106) #26200001 – #26293697	(#54107 –) #26294216 –	1/25	
17	WR11-3	(#53001 – #53172) #26200001 – #26293674	(#53173 –) #26293675 –	1/10	
18	WA200-3	(#10001 – #11429) #26200001 – #26293386	#26293635 –	1/11	
19	WR8-1	(#20001 – #20014) #26200001 – #26293386	(#20015 –) #26293635 –	1/10	
20	WA100M-3	(#10001 – #11156) #26200001 – #26293643	(#11157 –) #26293941 –	1/16	
21	BA200-1	(#1001 – #1004) #26200001 – #26292855		From the next order	
22	BA400-1	(#1001 – #1004) #26200001 – #26292855		From the next order	
23	BR100-1	(#1001 – #1237) #26200001 – #26292855		From the next order	

(Serial numbers of the machines are merely for your reference.)

No.	Machine models	Already shipped machines	Already modified factory shipment machines		Remarks
		Serial numbers of the machines	Serial numbers of the machines	Implementation starting from	
		Serial numbers of the engines	Serial numbers of the engines		
24	BZ100-1	(#1001 – #1036) #26200001 – #26292855			From the next order
25	BZ120-1	(#1001 – #1036) #26200001 – #26292855			From the next order
26	CD45R-1	(#1001 – #1005) #26200001 – #26293723	#26293724 –		1/10
27	GT60-1	— #26200001 – #26293723	—		From the next order
28	LC1285-1	— #26200001 – #26294208	— #26294209 –		1/25
29	LC605-2	— #26200001 – #26294208	— #26294209 –		1/25
30	LC755	— #26200001 – #26293396	—		From the next order
31	MK85	— #26200001 – #26294208	—		From the next order
32	MST500	— #26200001 – #26294208	—		From the next order
33	MST700	— #26200001 – #26294208	—		From the next order

2. SAA4D102E-2

No.	Machine models	Already shipped machines	Already modified factory shipment machines		Remarks
		Serial numbers of the machines	Serial numbers of the machines	Implementation starting from	
		Serial numbers of the engines	Serial numbers of the engines		
1	D39-21	(#1001 – #1121) #26280001 – #26285007	(#1122 –) From the next shipment		'01 12/18 –

3. (S)(A)(A)6D102E-1

* Machine models with which the oil level gauge has been modified (Factory shipment machines only)

No.	Machine models	Already shipped machines	Already modified factory shipment machines		Remarks
		Serial numbers of the machines	Serial numbers of the machines	Implementation starting from	
		Serial numbers of the engines	Serial numbers of the engines		
1	PC200-6	(#95001 – #110615) #26200001 – #26291057	(#110616 –) From the next shipment		1/17 –
2	PC210-6	(#30001 – #31920) #26200001 – #26291057	(#31921 –) From the next shipment		1/17 –
3	PC200-CA6	— #26200001 – #26292710	— #26292711 –		'01 11/26 – For BKC
4	PC200-DB6	— #26200001 – #26292073	— #26292074 –		'01 11/26 – For Komatsu Shantui
* 5	PC200-JK6	— #26200001 – #26291392	— From the next shipment		From the next shipment For KI

(Serial numbers of the machines are merely for your reference.)

3. (S)(A)(A)6D102E-1

* Machine models with which the oil level gauge has been modified (Factory shipment machines only)

No.	Machine models	Already shipped machines	Already modified factory shipment machines		Remarks
		Serial numbers of the machines	Serial numbers of the machines	Implementation starting from	
		Serial numbers of the engines	Serial numbers of the engines		
* 6	PC200-NL6	— #26200001 – #26292076	— #26292077 –	'01 11/26 –	For LTK
* 7	PC200-RT6	— #26200001 – #26292710	— From the next shipment	From the next shipment	For TEMSA
* 8	PC220-6	(#50001 – #56383) #26200001 – #26291933	(#56384 –) #26291934 –	'01 11/26 –	
* 9	PC220-DB6	— #26200001 – #26292349	— #26292350 –	'01 11/26 –	For Komatsu Shantui
* 10	PC230-6	(#10001 – #10334) #26200001 – #26291934	(#10335 –) #26291934 –	'01 11/26 –	
* 11	PC250-6	(#10001 – #10055) #26200001 – #26291933	(#10056 –) #26291934 –	'01 11/26 –	
* 12	PC228UU-1	(#10001 – #10591) #26200001 – #26290030	(#10592 –) From the next shipment	From the next shipment	
* 13	PC228UU-2 PC228US-2	(#15001 – #15920) #26200001 – #26275138	From the next shipment	From the next shipment	
* 14	PC308US-1	(#10001 – #10017) #26200001 – #26264227	(#10018 –) From the next shipment	'01 11/26 –	
* 15	BR210JG-1	(#1001 – #1170) #26200001 – #26292567	(#1171 –) #26292568 –	'01 11/26 –	
* 16	BR250JG-1	(#1001 – #1206) #26200001 – #26291933	(#1207 –) From the next shipment	'01 12/25 –	
* 17	BR350JG-1	(#1001 – #1507) #26200001 – #26291933	(#1508 –)	'01 12/25 –	
* 18	BZ200-1	(#1001 – #1147) #26200001 – #26292567	(#1148 –) #26292568 –	'01 11/26 –	
* 19	GT70-1	— #26200001 – #26291936	— From the next shipment	'01 12/25 –	
20	D41-6	(#50005 – #50240) #26200001 – #26287963	(#50241 –) From the next shipment	'01 12/11 –	
21	GD405A-3	(#5001 – #5348) #26200001 – #26292216	(#5349 –) #26292217 –	'01 11/26 –	
22	GD505A-3	(#2001 – #2054) #26200001 – #26291931	From the next shipment	'01 12/14 –	
23	GL521A-1	(#10001 – #12221) #26200001 – #26290035	From the next shipment	From the next shipment	
24	WA150-3	(#60001 – #64283) #26200001 – #26292543	(#64284 –) #26292544 –	'01 11/26 –	
25	WA180-3	(#50001 – #54351) #26200001 – #26291932	From the next shipment	'01 12/20 –	
26	WA180-JK3	— #26200001 – #26291932	— From the next shipment	1/8 –	For KI
27	WA200-3	(#60001 – #64337) #26200001 – #26292213	(#64338 –) #26292214 –	'01 11/26 –	
28	WA250-3	(#60001 – #66041) #26200001 – #26292556	(#66042 –) #26292557 –	'01 11/26 –	

(Serial numbers of the machines are merely for your reference.)

3. (S)(A)(A)6D102E-1

* Machine models with which the oil level gauge has been modified (Factory shipment machines only)

No.	Machine models	Already shipped machines	Already modified factory shipment machines		Remarks
		Serial numbers of the machines	Serial numbers of the machines	Implementation starting from	
		Serial numbers of the engines	Serial numbers of the engines		
29	WA300-3	(#50001 – #52149)	(#52150 –)	'01 11/26 –	
		#26200001 – #26291932	#26291933 –		
30	WA320-3	(#50001 – #54172)	(#54173 –)	'01 11/26 –	
		#26200001 – #26291932	#26291933 –		
31	WA320-DZ3	—	—	From the next shipment	For Komatsu Changlin
		#26200001 – #26290610	From the next shipment		
32	CD60R-1	(#1001 – #1973)	(#1974 –)	'01 11/26 –	
		#26200001 – #26292568	#26292569 –		
33	CL60-2	—	—	From the next shipment	
		#26200001 – #26292568	From the next shipment		
34	FD40	—	—	'01 11/23 –	
		#26200001 – #26291656	#26291657 –		
35	FD50	—	—	'01 11/23 –	
		#26200001 – #26291919	#26291920 –		
36	FD80	—	—	'01 11/23 –	
		#26200001 – #26292229	#26292230 –		
37	EG125BS-2	—	—	From the next shipment	
		#26200001 – #26247049	From the next shipment		
38	EG90BS-1	—	—	From the next shipment	
		#26200001 – #26247335	From the next shipment		
39	JV100-2	(#20001 – #21219)	(#21220 –)	'01 11/26 –	
		#26200001 – #26292554	#26292555 –		
40	DCA125	—	—	From the next shipment	
		#26200001 – #26289803	From the next shipment		
41	DCA115	—	—	From the next shipment	
		#26200001 – #26289803	From the next shipment		
42	DCA90	—	—	From the next shipment	
		#26200001 – #26217508	From the next shipment		
43	AG125	—	—	From the next shipment	
		#26200001 – #26292554	From the next shipment		
44	MK125	—	—	From the next shipment	
		#26200001 – #26292554	From the next shipment		
45	MST1100	—	—	From the next shipment	
		#26200001 – #26289803	From the next shipment		

(Serial numbers of the machines are merely for your reference.)

4. SAA6D102E-2

* Machine models with which the oil level gauge has been modified (Factory shipment machines only)

No.	Machine models	Already shipped machines	Already modified factory shipment machines		Remarks
		Serial numbers of the machines	Serial numbers of the machines	Implementation starting from	
		Serial numbers of the engines	Serial numbers of the engines		
* 1	PC200-7	(#200001 – #201261) #26200001 – #26292013	(#201262 –) #26292014 –	'01 11/26 –	
* 2	PC210-7	(#40001 – #40089) #26200001 – #26292013	(#40090 –) #26292014 –	'01 11/26 –	
* 3	PC220-7	(#60001 – #60062) #26200001 – #26292332	(#60063 –) #26292333 –	'01 11/26 –	
* 4	PC230-7	(#11001 – #11007) #26200001 – #26292332	(#11008 –) #26292333 –	'01 11/26 –	
* 5	PC228US-3	(#20001 – #21048) #26200001 – #26291976	(#21049 –) #26291975 –	'01 11/26 –	
* 6	PX500-1	#10001 #26288402	(#10002 –) From the next shipment	From the next shipment	
* 7	BR120-1	(#1001 – #1098) #26200001 – #26290339	(#1099 –) From the next shipment	1/7 –	
* 8	BZ210-1	(#1001 – #1014) #26200001 – #26290609	(#1015 –) From the next shipment	1/16 –	

(Serial numbers of the machines are merely for your reference.)