

PARTS & SERVICE NEWS

REF NO.	AT02185A
DATE	Sep. 5, 2003
(C) Page 1 of 4	

This PARTS & SERVICE NEWS supersedes the previous issue No. AT02185 dated Jan. 16, 2003 which should be discarded.

SUBJECT: INTRODUCTION OF SUBSTITUTION FOG LAMP ON HD465-5, HD605-5, HD785-3, -5, HD985-3, -5

PURPOSE: To introduce a substitute fog lamp for optional installation on HD465-5, HD605-5, HD785-3, HD785-5, HD985-3 and HD985-5 dump trucks

APPLICATION: HD465-5 Dump Trucks, Serial Nos. 4001 and up
 HD605-5 Dump Trucks, Serial Nos. 1001 and up
 HD785-3 Dump Trucks, Serial Nos. 2001 thru 2574
 HD785-5 Dump Trucks, Serial Nos. 4001 and up
 HD985-3 Dump Trucks, Serial Nos. 1001 thru 1020
 HD985-5 Dump Trucks, Serial Nos. 1021 and up

FAILURE CODE: DU1AZ9

DESCRIPTION:

1-1. Introduction

Since production of the round shaped spot type fog lamp which has been used as an optional part has been stopped, a square shaped spot type fog lamp will be employed as a substitute new part.

This Service News will introduce the specifications of this new optional fog lamp and necessary modification to make when installing it.

1-2. Revised places:

2 places 	Sep. 5, 2003	The bulb for replace is added.
--	--------------	--------------------------------

2. List of parts

No.	Part No.	Part Name	Q'ty	Remarks
1	561-85-14200 (561-86-13250)	Lamp, spot (Lamp, spot)	2 (2)	
2	566-06-34350 (. 566-95-14220)	. Bulb (. Bulb)	2 (2)	The bulb for replace.
2	561-85-61211 (561-85-61210)	Bracket (Bracket)	2 (2)	The current bracket 561-85-61210 may also be used after additional working.
3	565-95-18170 (568-06-12150)	Cable (Cable)	2 (2)	Power cable
4	568-06-12260	Cable	2	Grounding cable
5	08037-01008	Grommet	2	
6	01010-80812	Bolt	2	
7	01643-30823	Washer	2	
8	01643-31232	Washer	6	

3. Details of the modification

Refer to the table indicated below regarding the details of the specification changes for the new and current fog lamps.

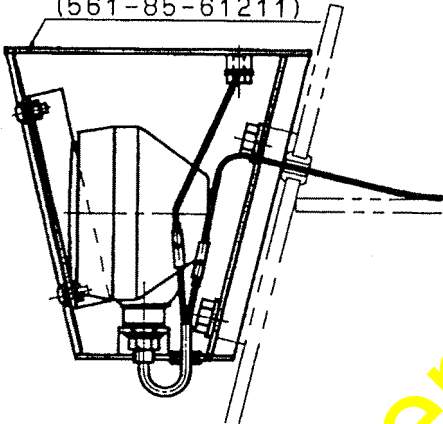
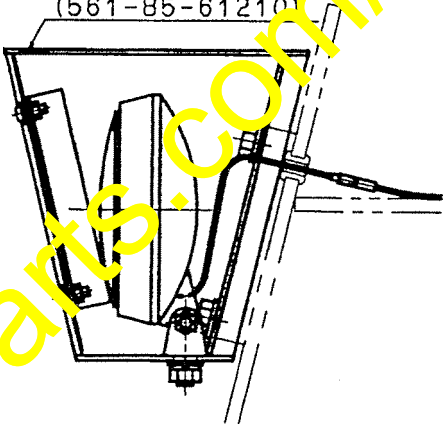
	New (substitute) fog lamp	Current fog lamp (Production has been stopped.)
Part No. of the fog lamp	561-95-14200	581-96-13250
 Part number of the bulb for replace	196-06-34350	566-95-14220
Installation method	Bracket (561-85-61211) 	Bracket (561-85-61210) 
Lens shape	Square shape	Round shape
Rating	55 W / 24 V	55 W / 24 V
Diffusion angle	14°, spot	8°, spot

4. Replacement procedure

- (1) Park the vehicle on a flat place and apply chocks underneath each tire.
- (2) Remove the bracket (561-85-61210).

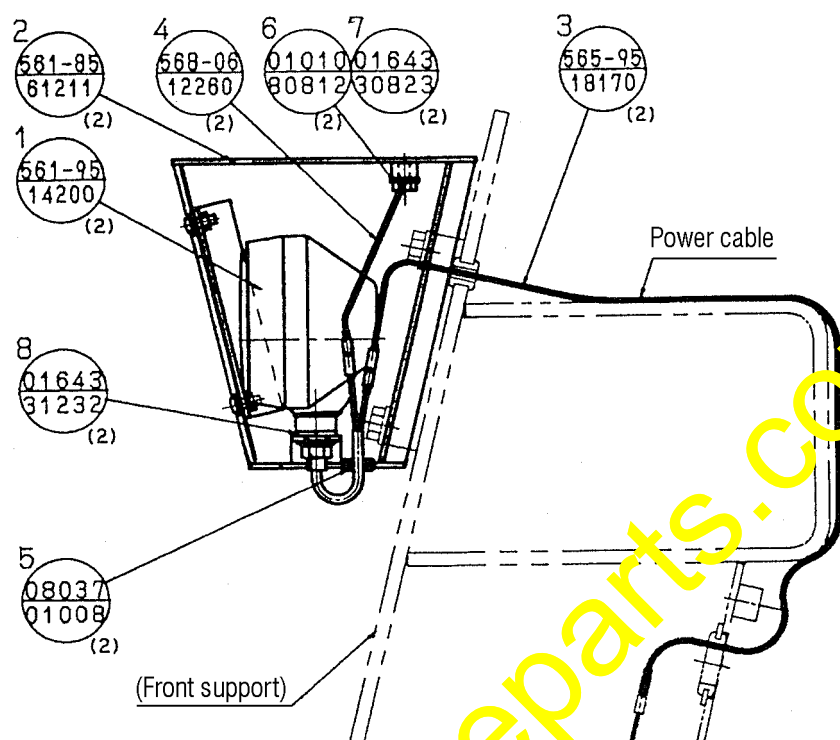

- (3) Change the power cable coming from the headlamp from 568-06-12150 (total length: 500) to the new power cable 3 (565-95-18170) (total length: 700).
- (4) Connect the grounding cable 4 (568-06-12260) to the seat of the bracket 2 (561-85-61211).
Also, install the grommet 5 (08037-01008) into the hole ($\phi 15$) shown in the above drawing.
- (5) Install the bracket 2 (561-85-61211) to the front support.
- (6) After connecting the power cable 3 and the grounding cable 4 to the substitute fog lamp 1 (561-95-14200), mount the fog lamp to the bracket 2. At this time, insert a piece of washer 8 (01643-31232) into the position shown in the above drawing.

5. Replacement procedure in case the current lamp mounting bracket is used after making additional working

Although replacement of the fog lamp mounting bracket is recommended in the list of necessary parts in order to make the installation work easier, it is also possible to reuse the current bracket after making an additional working.

In this case, make the additional working as per the instructions given below.

- (1) Park the vehicle on a flat place and apply chocks underneath each tire.
- (2) Additional working for the bracket
 - (a) Remove the bracket (561-85-61210).

- (b) Weld 1 piece of the seat (01572-20812 or 01571-00814) to the position shown in the drawing below. Also, drill a $\phi 12.5$ hole (at 1 place).

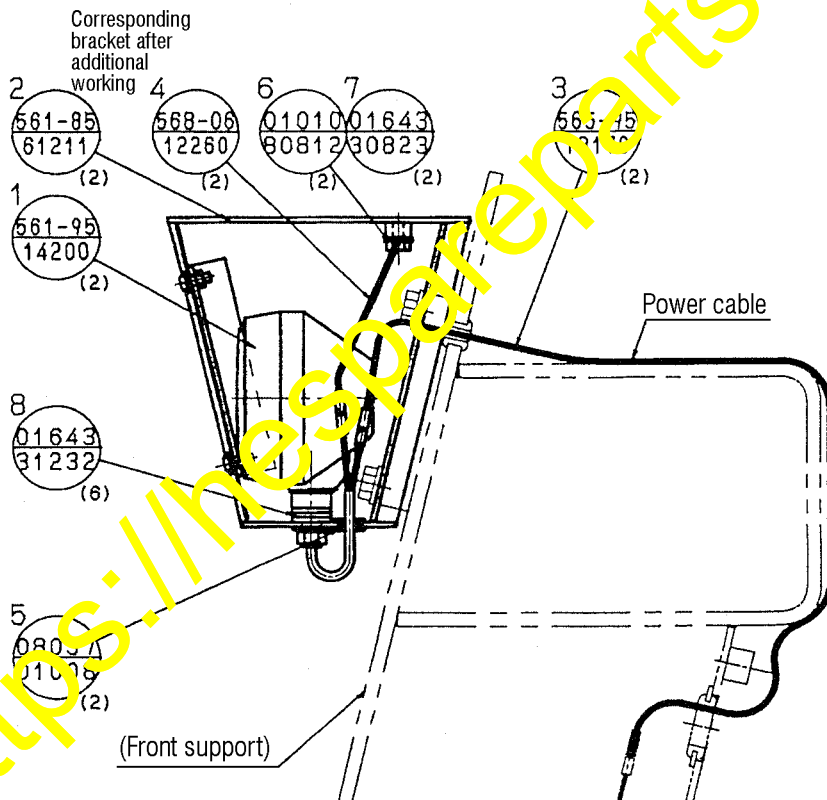
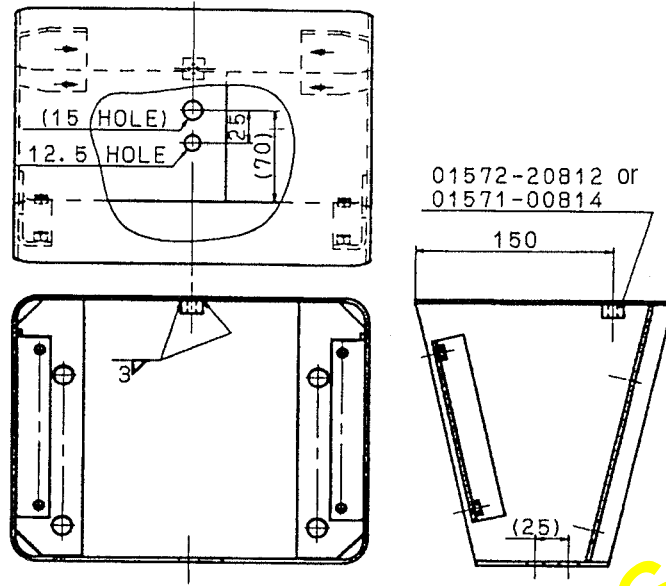

- (3) Change the power cable coming from the headlamp from 568-06-12150 (total length: 500) to the new power cable 3 (565-95-18170) (total length: 700).
- (4) Connect the grounding cable 4 (568-06-12260) to the seat of the additionally worked bracket 2 (corresponding to 561-85-61211). Also, install the grommet 5 (08037-01008) into the hole ($\phi 15$) being opened as per the above drawing.
- (5) Install the additionally worked bracket 2 (corresponding to 561-85-61211) to the front support.
- (6) After connecting the power cable 3 and the grounding cable 4 to the substitute fog lamp 1 (561-95-14200), mount the fog lamp to the bracket 2. At this time, insert 3 pieces of washers 8 (01643-31232) into the position shown in the above drawing.