

PARTS & SERVICE NEWS

REF NO.	AT03045
DATE	Apr. 4, 2003

Page 1 of 2

SUBJECT: IMPROVEMENT OF REAR TIRE MUDGUARD FENDER ON HD465-7, HD605-7

PURPOSE: To introduce modification procedure to prevent occurrence of riding of the mud guard rubber on the hydraulic oil tank and its resultant deformation on HD465-7 and HD605-7 dump trucks

APPLICATION: HD465-7 Dump truck, Serial Nos. 7001 thru 7089
HD605-7 Dump truck, Serial Nos. 7001 thru 7040

FAILURE CODE: 54A0EA

DESCRIPTION:

1. Introduction

On the HD465-7 and HD605-7 dump trucks in the field, the mud guard rubber for the rear tires may come up over the hydraulic oil tank when the dump body is lowered resulting in deformation of the mud guard rubber.

This Service News will introduce the modification procedure to prevent occurrence of the aforementioned riding of the mud guard rubber and resultant deformation thereof.

2. List of parts

Part No.	Part Name	Purpose of part	Q'ty	Remarks
569-99-82290	Plate	} Replacement	2	Additionally working parts
(569-74-61660)	(Guard)		(2)	
(569-74-61660)	(Guard)		(2)	
01010-81230	Bolt		14	
01643-31230	Washer		14	

3. Details of the modification

- To prevent occurrence of the interference between the mud guard rubber and the hydraulic oil tank, an angle changing plate is to be added between the mud guard rubber mounting support and the body and the length of the mud guard rubber is to be changed.

3-1. Preparations before starting the modification work

- (1) Park the vehicle on a flat place, apply the parking brake and turn "OFF" the main switch. After that, insert chocks under each tire.
- (2) When carrying out this modification work the dump body raised, be sure to insert the safety pins.

3-2. Modification procedure

- (1) Remove the supports A and B (569-74-61630 (LH) and 569-74-61640 (RH)).
(Since removed bolts and washers are being reused, store them carefully.)

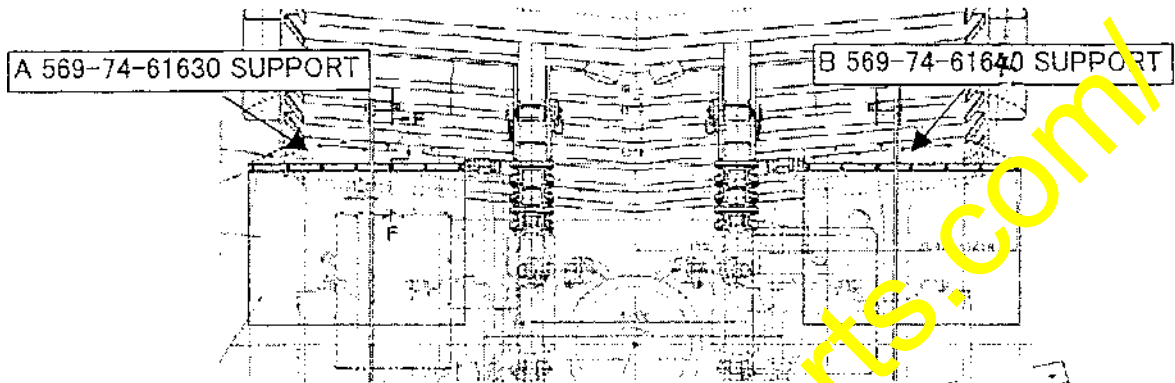

- (2) Cut the mud guard rubber ② (569-74-61660) at the position of 260 mm from the low end.
(A cutter knife available on the market can be used for cutting of the mud guard rubber.)

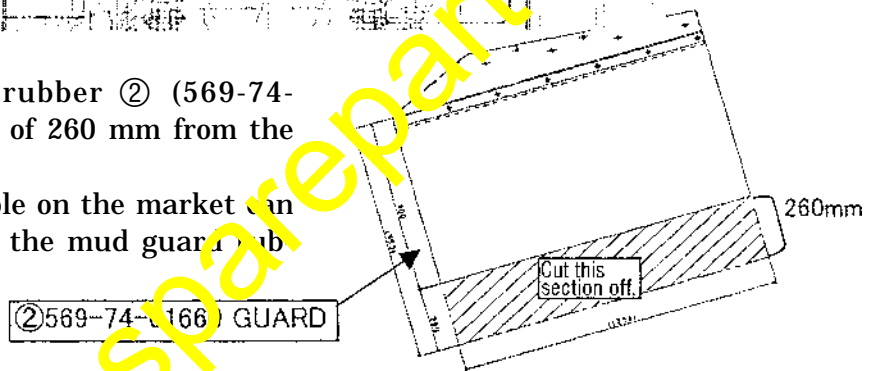

- (3) Install the plate ① (569-99-32290) to the body using the bolt ③ (01010-81230) and washer ④ (01643-31232). At that time, be careful not to make directional error.
- (4) Install the supports A and B which have been removed as per the above Section (1) to the plate ①.

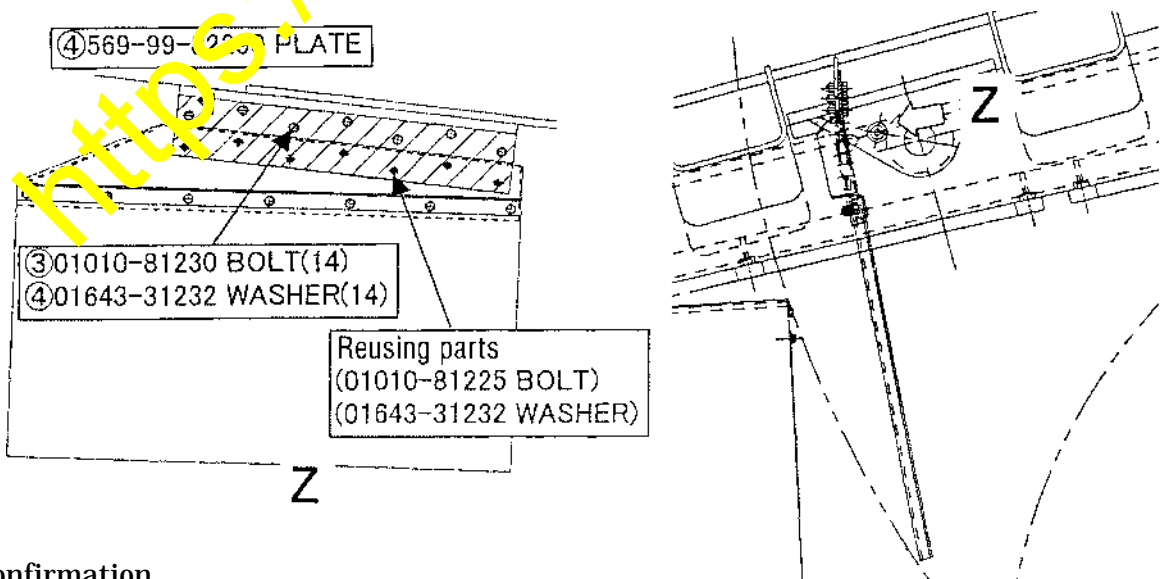

3-3. Confirmation

- Raise and lower the dump body to confirm that the mud guard rubber will not interfere with the hydraulic oil tank.