

**PARTS & SERVICE
NEWS**

REF NO.	AT03115
DATE	Jun. 27, 2003

Page 1 of 3

SUBJECT: CON-ROD WITH MARGIN INCREASED FOR SMALL END BREAKAGE
ON SAA6D170E-3

PURPOSE: To introduce modification procedure to increase the margin against breakage of the smaller end of the connecting rod for the SAA6D170E-3 engines

APPLICATION: Refer to page 3.

FAILURE CODE: A370FF

DESCRIPTION:

1. Introduction

With the SAA6D170E-3 engines, when the smaller end of the connecting rod broke or cracked, make the modification being introduced in this Service News to repair the failure and to increase the margin against the breakage.

2. List of parts

Part No.	Part Name	Purpose of part	Q'ty	Remarks
6240-31-3102 (6240-31-3101)	Conrod ass'y (Conrod ass'y)	Replacement	6 (6)	

3. Details of the modification

In order to increase the margin against occurrence of cracks in the smaller end of the connecting rod, the shape of the smaller end has been improved. (Refer to Fig. 1 regarding the improved section.)

- (1) Spot facing height : 53 mm ← 48 mm
- (2) Spot facing diameter : $\phi 20$ ← $\phi 30$
- (3) Radius under spot facing : R5 – R8 ← —

<Identification method>

Identify the new and current parts by the spot facing diameter of the upper section of the smaller end of the connecting rod.

Fig. 1

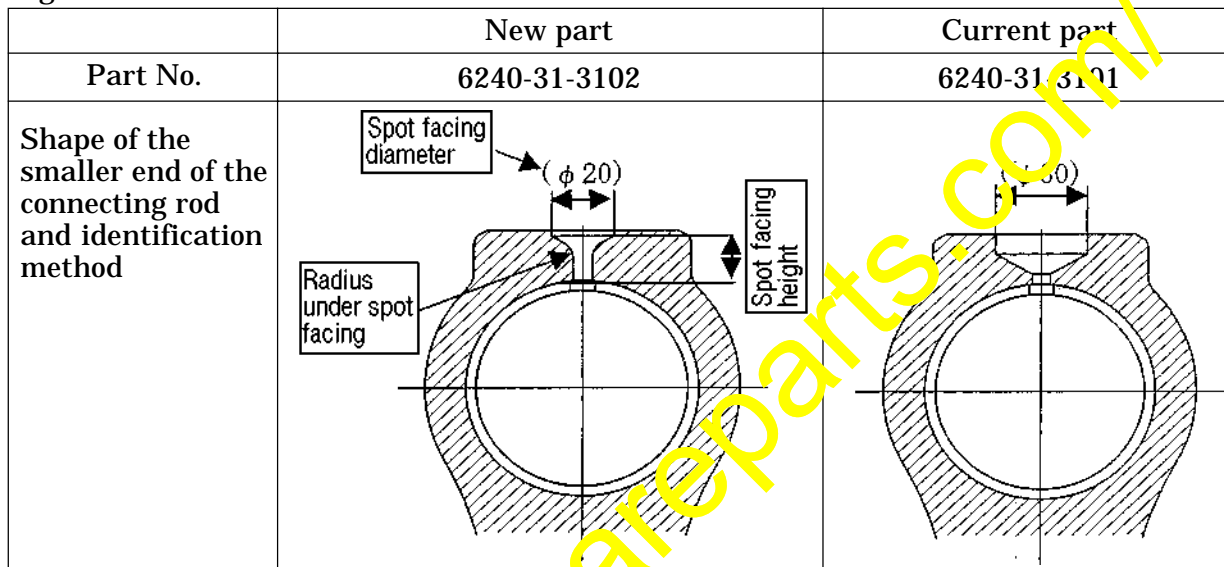

4. Modification procedure

- (1) Pull out the connecting rod referring to the Shop Manual for the engine.
- (2) Replace the connecting rod ass'y with the improved ass'y.
- (3) Replace the consumable parts like the gasket, etc. with new parts.
- (4) Carefully check if other related parts are not damaged and if any of them are damaged, replace them at the same time.
 - 1) The head and related parts (head, valve, valve cock and cross-head)
 - 2) The cylinder block and related parts (cylinder block, cylinder liner and cam bushing)
 - 3) The piston and related parts (piston, ring and pin)
 - 4) The crank and related parts (crank and bearing)
 - 5) The rocker arm and related parts (rocker arm ass'y and push rod)
 - 6) The cam and related parts (cam shaft and cam follower ass'y)
 - 7) The injector and related parts (injector and clamp)
- (5) Reinstall the removed parts referring to the Shop Manual.
 - In case the cylinder block is being damaged, use the following short block.

Table 1

Applicable machine model	Part No. of the short block
WA600-3, WA700-3, WD600-3	6241-SE-0010
HD465-7, HD605-7	6241-SE-0020
PC1250-7	6241-SE-0030
D375A-5	6240-SE-0010

- (6) When tightening the connecting rod bolt, it is recommended to use the nut runner by use of which it becomes possible to make turning angle tightening.

Check table of the serial numbers of the applicable machines of the major machine models

All the serial numbers start from the initial number. (03/4/8 and after)

No.	Applicable machine model	Serial No. of the applicable engine		Serial No. of the applicable machine	
		Already shipped engine	Factory shipment engine	Already shipped machine	Factory shipment machine
1	WA600-3E	- #310607	#310629 -	- #52058	#52059 -
2	WA600-AC-3	- #310548	#310642 -		
3	WD600-3	- #310536	#310732 -	- #50002	#50003 -
	WA700-3	- #310471	#310651 -	- #51003	#51004 -
4	HD465-7	- #310623	#310637 -	- #7079	#7080 -
5	HD605-7	- #310623	#310637 -	- #7040	#7041 -
6	D375A-5	- #310627	#310640 -	- #1813	#18137 -
7	PC1250-7	- #310636	#610638 -	- #20053	#20054 -
8	A6D170E-G1-3	- #310628	#310632 -		
9	A6D170E-KC	- #310157	#310746 -		
10	170CUM-PG3	- #310579	Next production		
11	170CUM-IND	- #310512	#310735 -		
12	WA600-3D	- #310607	#310629 -	#53001 - #53014	#53015 -