

**PARTS & SERVICE
NEWS**

REF NO.	AT03227
DATE	Dec. 8, 2003

(C) Page 1 of 6

SUBJECT: MODIFICATION PROCEDURE TO INSTALL YELLOW WARNING LIGHT ON WA100-5 TO WA320-5 CAB (SINGLE OPERATOR)

PURPOSE: To introduce a modification procedure to add the mounting seats for the single operator cab spec. light diffusing revolving lamp and yellow colored revolving warning light onto WA100-5 thru WA320-5 wheel loaders

APPLICATION: WA100-5 Wheel Loaders, Serial Nos. 70001 and up
 WA150-5 Wheel Loaders, Serial Nos. 65001 and up
 WA200-5 Wheel Loaders, Serial Nos. 65001 and up
 WA270-5 Wheel Loaders, Serial Nos. 70001 and up
 WA320-5 Wheel Loaders, Serial Nos. 60001 and up

FAILURE CODE: DUB0Z9

DESCRIPTION:

1. Introduction

When locally installing the single operator cab spec. light diffusing revolving lamp and the yellow colored revolving warning light onto the WA100-5 thru WA320-5 wheel loaders, add the mounting seats on the upper surface of the operator's cab roof as per the instructions given in this Service News.

2. List of parts

Part No.	Part Name	Q'ty	Remarks
01571-00814	Seat	7	
416-926-3780	Sheet	1	
423-56-21310	Button	13	

3. Removal of the interior parts from the operator's cab

※ **Caution**

To prevent occurrence of fire, adhesion of splashing spatters and thermal damage by welding, remove the interior parts, etc. from the operator's cab and apply necessary masking.

Pay special attention to the glass.

- ① Remove the interior parts (1) thru (7) from the operator's cab.
Since the removed parts, bolts, screws, washers, etc. are being reused when making the restoration work, keep them carefully.
Discard the roof pad fixing buttons.

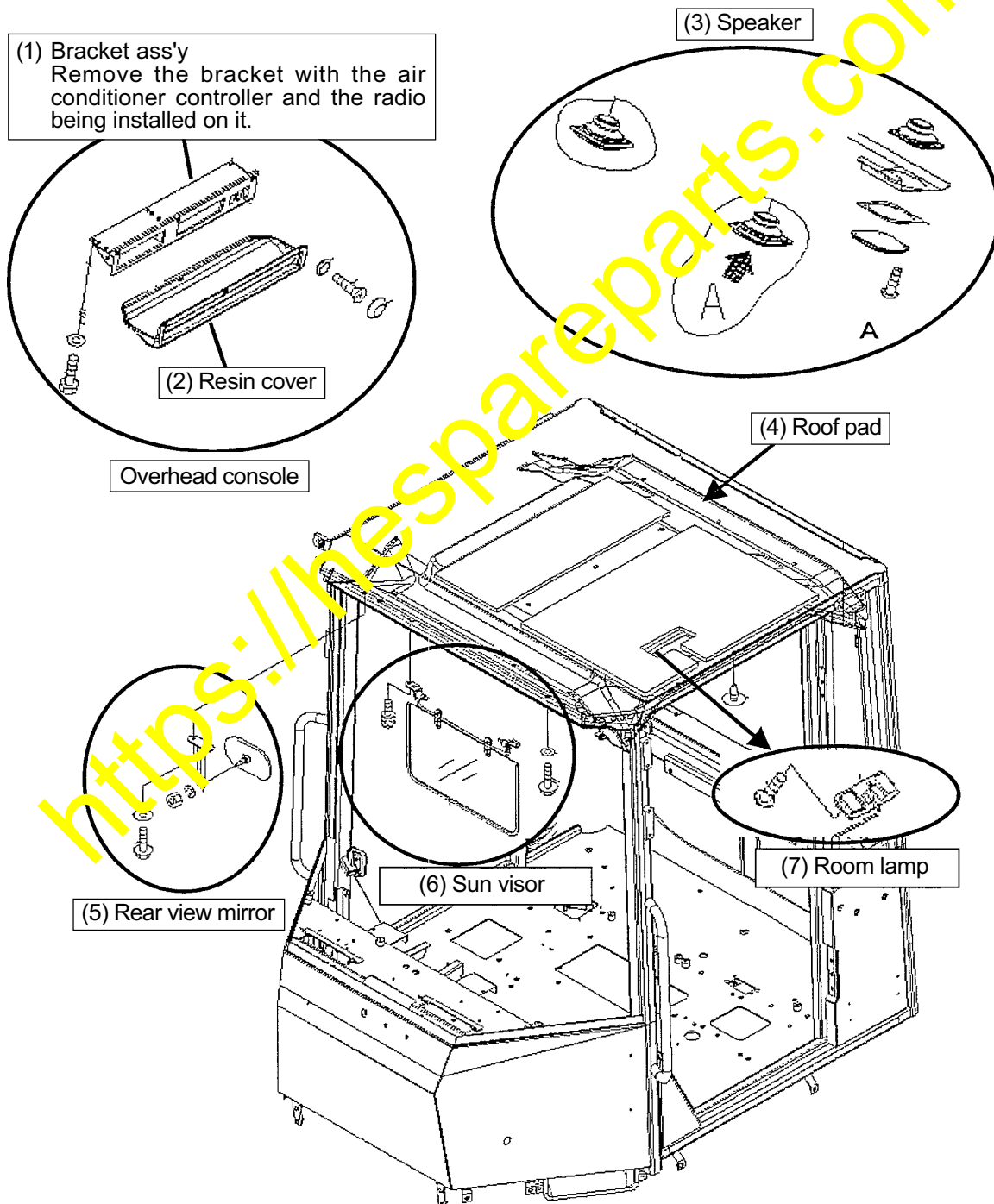

- ② Note) To prevent damage by the welding heat, remove the clamps of the cab harness and keep the cab harness away from the upper surface of the roof.

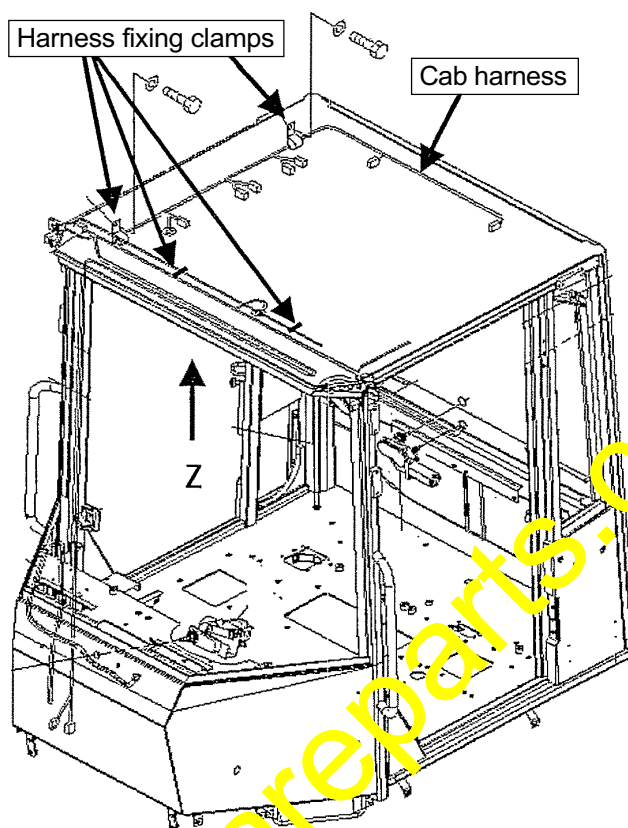

- ③ To prevent influence of the heat generated when welding the seats, cut the sound absorbing material. (The hatched sections at the 5 places shown in the drawing below)

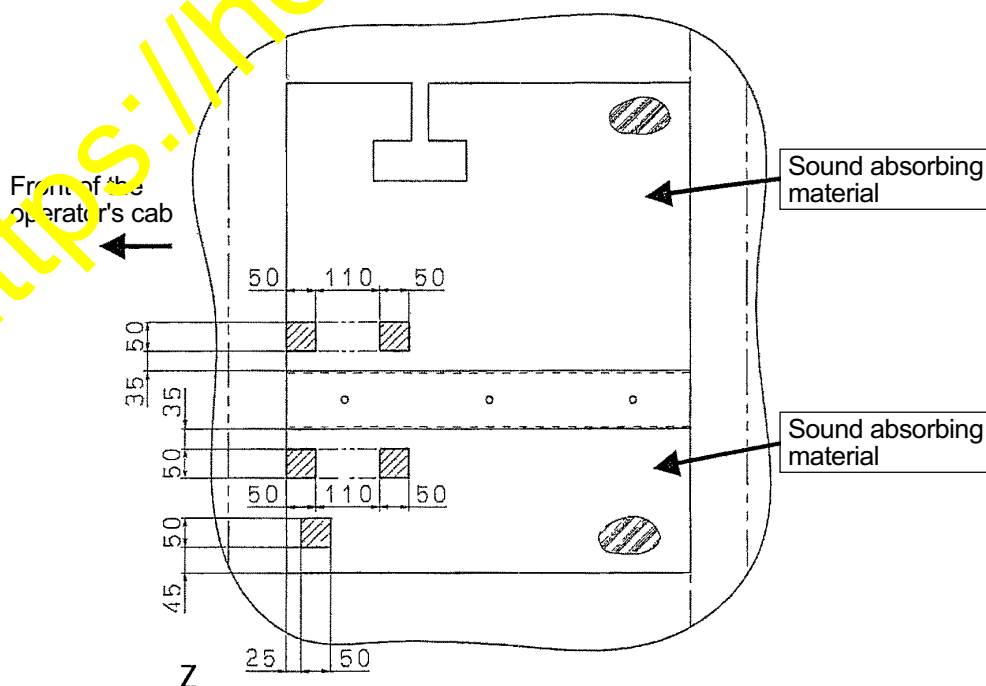

When viewed from the inside of the operator's cab

4. Procedure to add the mounting seats

- Weld 7 pcs. of the seats (01571-00814) to the upper surface of the roof.

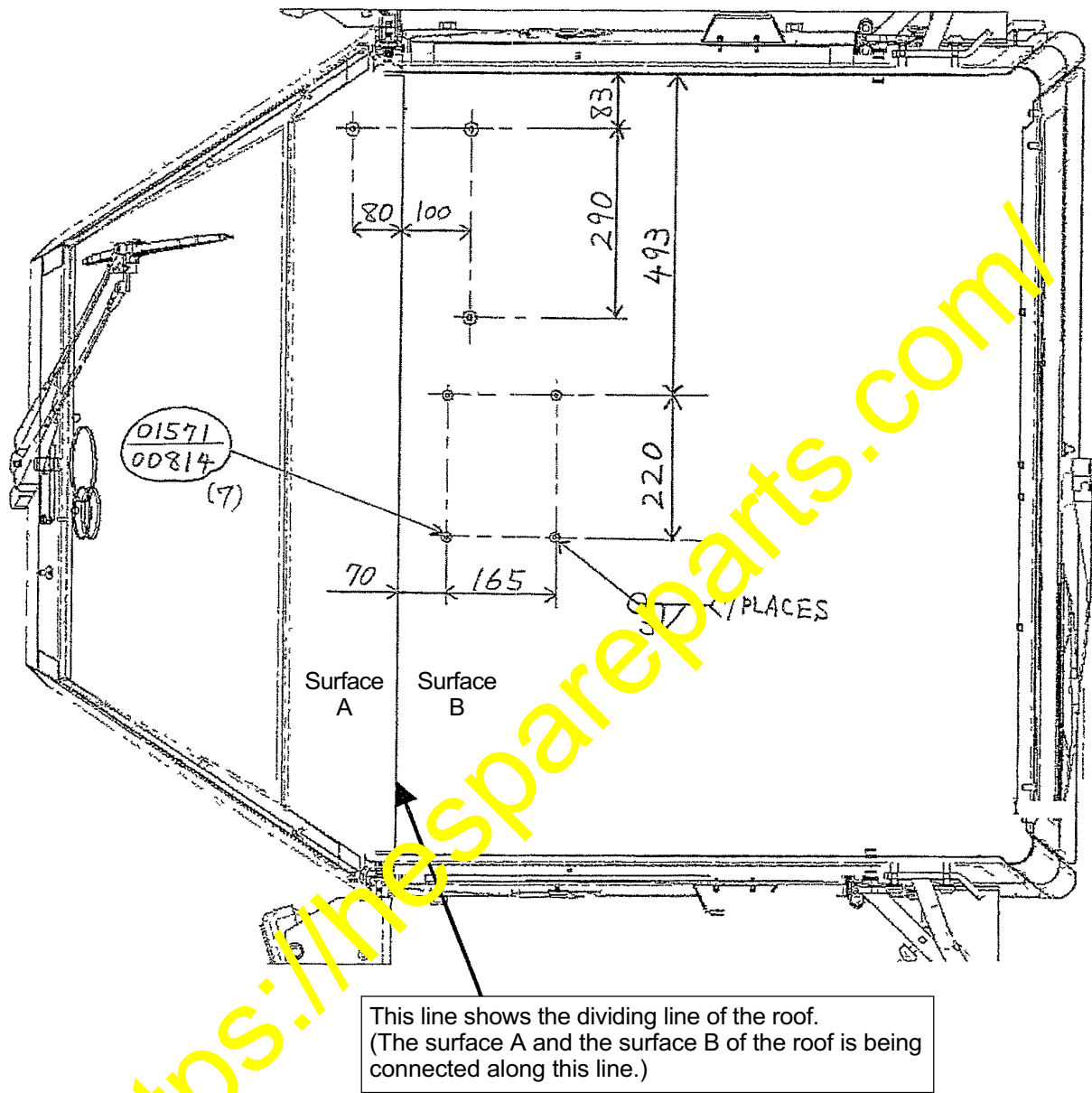

When viewed from the upper side of the roof

- After finishing the welding work, apply paint. (Paint color: Natural Yellow)

5. Installation of the interior parts

- Reinstall the parts which have been removed as per "Section 3. Removal of the interior parts from the inside of the operator's cab".

When reinstalling these parts, regarding the roof pad fixing buttons, use the newly arranged parts.

Regarding other parts like bolts, screws, washers, etc., reuse the removed parts.

Fill the square holes which have been cut out as per Section 3-③ referring to the instructions given on page 6.

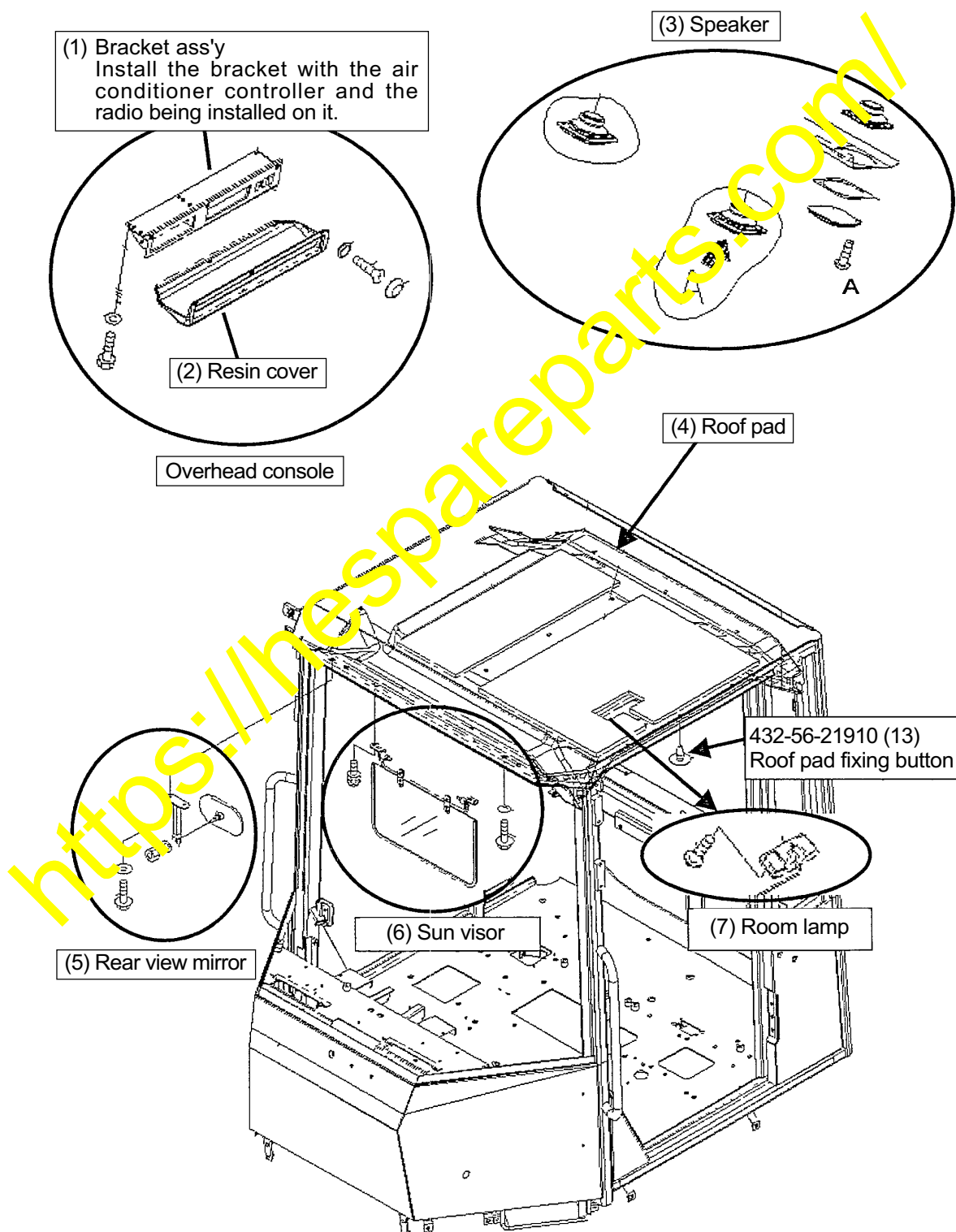

6. Reworking procedure and sticking procedure for the sound absorbing material

- Cut the sound absorbing material (416-926-3780) to the following dimensions (50 × 50).

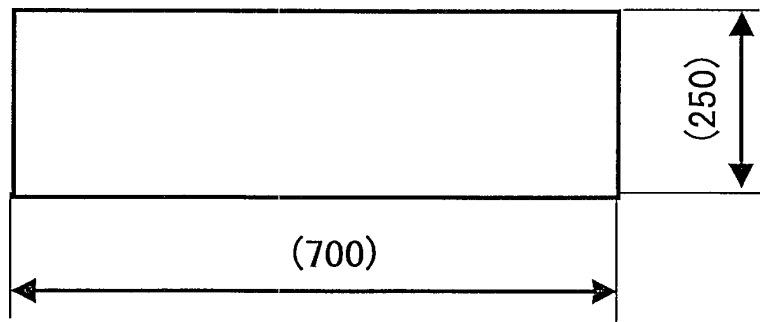

Part No. of the arranged parts: 416-926-3780

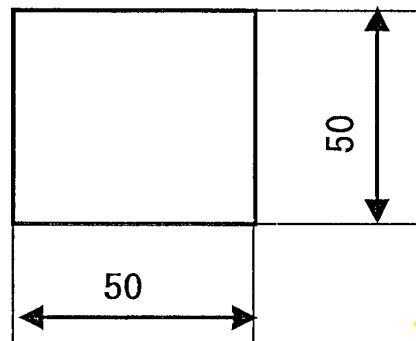

- Make out 5 pcs of the cut sound absorbing materials for a machine.

• Sticking procedure

Stick the above parts to the square holes cut in the sound absorbing material as per Section 3-③ (the hatched sections at the 5 places shown in the drawing below).

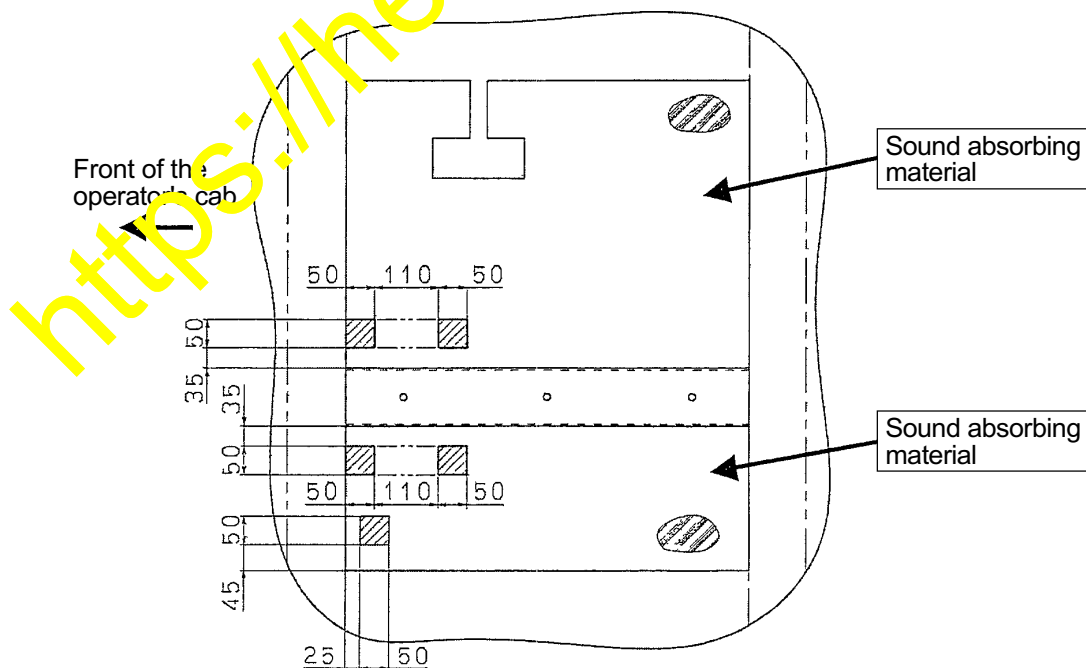

When viewed from the inside of the operator's cab