

# PARTS & SERVICE NEWS

REF NO.	AT04021
DATE	Feb. 25, 2004
(C)	Page 1 of 3

**SUBJECT:** REPLACEMENT OF NAME PLATE OF ROPS CAB ON GD555-3C, 3A  
GD655-3C, 3A, GD675-3A

**PURPOSE:** To introduce replacement procedure of the name plate of the ROPS cab on GD555-3A/3C, GD655-3A/3C and GD675-3A/3C motor graders

**APPLICATION:** GD555-3A Motor Graders, Serial Nos. 11001 thru 11018  
GD555-3C Motor Graders, Serial Nos. 51001 thru 51010  
GD655-3A Motor Graders, Serial Nos. 11001 thru 11009  
GD655-3C Motor Graders, Serial Nos. 51001 thru 51018  
51021 thru 51070  
GD675-3A Motor Graders, Serial Nos. 11001 thru 11007  
GD675-3C Motor Graders, Serial Nos. 51001 and up

**FAILURE CODE:** 5560Z9

**DESCRIPTION:**

1. Introduction

Since there were stamping errors on the name plate of the ROPS cab being attached to the GD555-3A/3C, GD655-3A/3C and GD675-3A/3C motor graders which have been shipped out, replace the name plate with the new plate being sent to you directly from our plant.

2. Replacement of the name plate of the ROPS cab being attached to the GD555-3A/3C, GD655-3A/3C and GD675-3A/3C motor graders

Since there were errors found in the weight indication stamping on the name plate of the ROPS cab being attached to the GD555-3A/3C, GD655-3A/3C and GD675-3A/3C motor graders which have been shipped out, replace the name plate with the new plate being sent to you directly from our plant.

(1) Details of the corrections

- The following two types of the name plates are being used.

09620-30200, 09620-10200

(For English speaking areas (excluding the U.S.A.) and Spanish speaking areas)

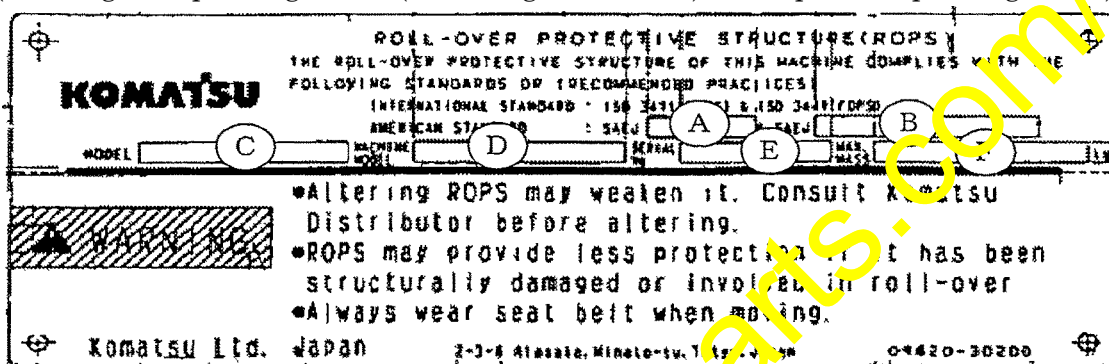

09620-30201 (USA)

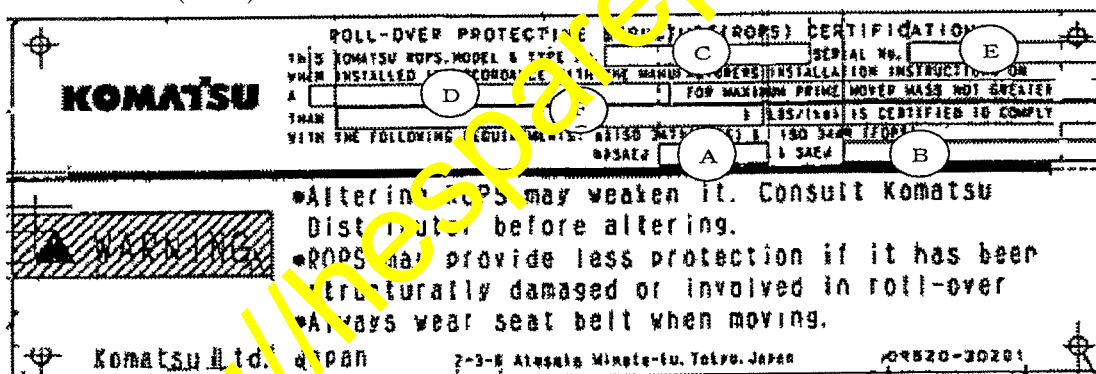

- Descriptions of the new name plate are as follows.
- The weight indications on the Item ⑥ have been corrected as seen in the Table shown below.
- The Production No. of the ROPS cab is not stamped on the new name plate. Stamp the same Production No. as stamped on the column ⑥ of the current name plate on the column ⑥ of the new name plate before attaching it to the machine. (Refer to the next page regarding the stamping procedure.)

ItemNo.	①	②	③		④	⑤	⑥	
			Low rops	High rops			09620-30201	09620-30200 09620-10200
Current	-	1040MAY94	6GB45	6GB41	GD655-3 or GD670-3	Production No. of each ROPS cab (4 figures)	41225(18700)	18700
New	No correction (Same stampings as on the current name plate are stamped.)					*No stamping (Blank)	Corrected ↓ 47180(21400)	Corrected ↓ 21400

## (2) Replacement work procedure

## 1) Removal of the current name plate

※ Remove the current name plate attached to the ROPS cab.

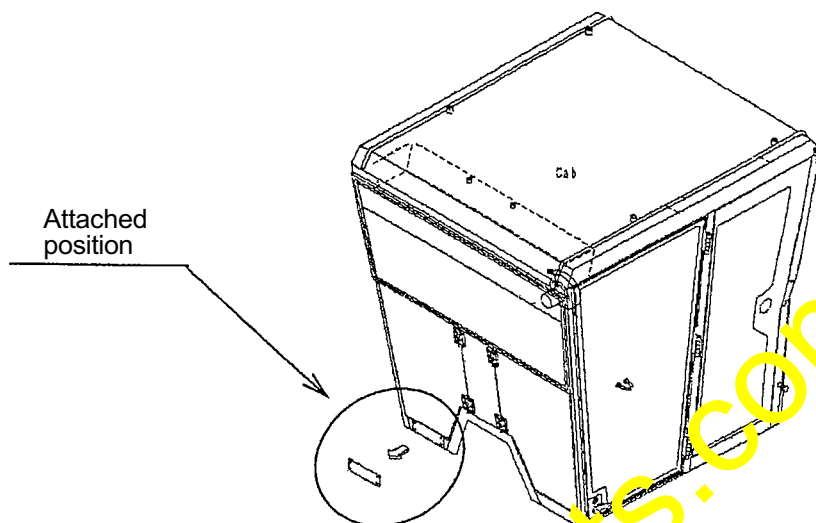

## 2) Stamp the Production No. (Serial No.) on the new name plate.

- Since the column ⑤ of the new name plate is in blank, be sure to stamp the same Serial No. as the one stamped on the current name plate.
- The position to stamp the Production No. (Serial No.) is on the column ⑤ per the Section (1) "Details of the corrections".
- Stamping letter size: Stamp the number at the size of 3.2 mm.

## 3) Attaching the new name plate

※ Attach the new name plate on which stamping of the Serial No. has been made as per the above Process 2) on the ROPS cab.  
Use 4 pcs. of the screws (04418-13060) to attach the name plate.

