

PARTS & SERVICE NEWS

REF NO. AT04222

DATE August 2, 2004

(C)

Page 1 of 9

SUBJECT: FILTER CARTRIDGE FOR FUEL FILTER FOR LOW GRADE FUEL USED ON TIER 2 (125, 140 AND 170 SERIES ENGINES)

PURPOSE: To inform Field Personnel

APPLICATION: SA6D125E-3 Engines, S/N 310001 thru 314072
SA6D140E-3 Engines, S/N 110001 thru 113265
SA6D170E-3 Engines, S/N 310000 and up
SAA6D125E-3 Engines, S/N 310001 thru 314072
SAA6D140E-3 Engines, S/N 110001 thru 113265
SAA6D170E-3 Engines, S/N 310000 and up
SDA6D140E-3 Engines, S/N 110001 thru 113265

FAILURE CODE: A7W0NX

DESCRIPTION:

1. Introduction:

The 125 bore or larger Tier 2 engines are equipped with an electronic control type of high pressure fuel injection units (CRI and HIPI). These units use more delicate precision parts as compared with the conventional mechanical fuel injection units that use fuel (low grade) containing dust and water; therefore they require a higher efficiency fuel filter system than the conventional fuel filter. This **Parts & Service News** introduces the fuel filter system and the latest filter cartridge. When replacing the filter cartridge, use this **Parts & Service News** as to installing a proper cartridge.

Refer to attached "*list of cartridge for fuel filter as spare parts including parts*" about part numbers of fuel filter cartridge and models. We introduced parts mentioned in **Parts & Service news AT03059 "Instructions for proper injector installation on SA(A)6D140 engines"**.

Part No.	Part Name	Qty.	Remarks
600-319-3510 (600-319-3310)	Filter (Filter)	1 (1)	Using for 125/140 engine main filter
600-319-3200	Filter	4	Using for 170 engine main filter. Changed from 2 pcs per unit to 4 pcs per unit.

1) List of cartridge part numbers for fuel filter as spare parts including parts (including the additional fuel filter for low grade fuel use areas)

NO	Model	Engine	Fuel injection unit	Fuel filter (Latest)			Fuel filter (Old)			Additional filter mounting position	Remark 1 See Service News**** (Procedure for supporting a unit with extended fuel filter)	Remark 2 Additional filter type				
				Main*	Pre (Additional filter)**	Water separator	Main	Pre (Additional filter)	Water separator							
				Cartridge part No.	Q'ty	Cartridge part No.	Q'ty	Cartridge part No.	Q'ty	Cartridge serial No.	Q'ty					
125Eng (For tier 2)																
1	PC400-7	SAA6D125-3	CRI	600-319-3510	1	600-319-3400	1	(Consolidated in the part number on the left)	600-319-3310	1	Need not be modified (Same as the latest)	Engine	Registered for the first S/N and after	Additional filter with clear ball (white)		
2	WA470-5	SAA6D125-3	CRI	600-319-3510	1	600-319-3400	1	(Consolidated in the part number on the left)	600-319-3310	1	None	421-Z02-3110	Machine body	Additional filter with clear ball (white)		
3	WA480-5	SAA6D125-3	CRI	600-319-3510	1	600-319-3400	1	(Consolidated in the part number on the left)	600-319-3310	1	None	421-Z02-3110	Machine body	Additional filter with clear ball (white)		
4	D65-15	SA6D125E-3	CRI	600-319-3510	1	600-319-3400	1	(Consolidated in the part number on the left)	600-319-3310	1	Need not be modified (Same as the latest)	Engine	Registered for the first S/N and after	Additional filter with clear ball (white)		
5	D85-15	SA6D125E-3	CRI	600-319-3510	1	600-319-3400	1	(Consolidated in the part number on the left)	600-319-3310	1	Need not be modified (Same as the latest)	Engine	Registered for the first S/N and after	Additional filter with clear ball (white)		
6	HM300-1	SAA6D125-3	CRI	600-319-3510	1	600-319-3400	1	(Consolidated in the part number on the left)	600-319-3310	1	Need not be modified (Same as the latest)	Machine body		Additional filter with clear ball (white)		
7	HD255-1	SAA6D125-3	CRI	600-319-3510	1	Not registered			600-319-3310	1	Not set			No low grade		
8	GD755-3	SAA6D125-3	CRI	600-319-3510	1	Not registered			600-319-3310	1	Not set			Domestic specifications only	Overseas specifications <G> to be evaluated on July 2004	
9	GH320-3	SAA6D125-3	CRI	600-319-3510	1	Not registered			600-319-3310	1	Not set			Domestic specifications only	Overseas specifications <G> to be evaluated on July 2004	
140Eng (For tier 2)																
1	PC600-6	SA6D140E-3	CRI	600-319-3510	1	600-319-3310 ***	2	600-311-9711	600-311-3110	1	600-311-7111	2	600-311-9711	Machine body	AT02004	Specifications with twin additional filters
				600-319-3510	1	600-319-3400	1	(Consolidated in the part number on the left)	600-311-3110	1	Need not be modified (Same as the latest)	Machine body	BT03049	Additional filter with clear ball (white)		
				600-319-3510	1	600-319-3400	1	(Consolidated in the part number on the left)	600-319-3310	1	Need not be modified (Same as the latest)	Machine body		Additional filter with clear ball (white)		
2	PC600-7	SA6D140E-3	CRI	600-319-3510	1	600-319-3400	1	(Consolidated in the part number on the left)	600-319-3310	1	Need not be modified (Same as the latest)	Machine body	Registered for the first S/N and after	Additional filter with clear ball (white)		
3	PC750-6	SAA6D140E-3	CRI	600-319-3510	1	600-319-3310 ***	2	600-311-9711	600-311-3110	1	600-311-7111	2	600-311-9711	Machine body		Specifications with twin additional filters
				600-319-3510	1	600-319-3400	1	(Consolidated in the part number on the left)	600-311-3110	1	Need not be modified (Same as the latest)	Machine body	BT03028	Additional filter with clear ball (white)		
				600-319-3510	1	600-319-3400	1	(Consolidated in the part number on the left)	600-319-3310	1	Need not be modified (Same as the latest)	Machine body		Additional filter with clear ball (white)		
4	PC750-7	SAA6D140E-3	CRI	600-319-3510	1	600-319-3400	1	(Consolidated in the part number on the left)	600-319-3310	1	Need not be modified (Same as the latest)	Machine body	Registered for the first S/N and after	Additional filter with clear ball (white)		
5	PC1800-6	SAA6D140E-3	CRI	600-319-3510	1	600-319-3400	1	(Consolidated in the part number on the left)	600-319-3310	1	Not set	600-311-9711	Engine		Not registered at the beginning	
				600-319-3510	1	600-319-3400	1	(Consolidated in the part number on the left)	600-319-3310	1	Need not be modified (Same as the latest)	Engine	BT03027	Additional filter with clear ball (white)		
6	D155AX-5A	SA6D140E-3	CRI	600-319-3510	1	600-319-3400	1	(Consolidated in the part number on the left)	600-319-3310	1	Not set	600-311-9711	Machine body		Not registered at the beginning	
				600-319-3510	1	600-319-3400	1	(Consolidated in the part number on the left)	600-319-3310	1	Need not be modified (Same as the latest)	Engine	AT03090	Additional filter with clear ball (white) / rubber mount		
7	D155AX-5B	SA6D140E-3	CRI	600-319-3510	1	600-319-3400	1	(Consolidated in the part number on the left)	600-319-3310	1	Need not be modified (Same as the latest)	Engine	Registered for the first S/N and after	Additional filter with clear ball (white)		
8	D275A(X)-5	SDA6D140E-3	CRI	600-319-3510	1	600-319-3400	1	(Consolidated in the part number on the left)	600-319-3310	1	Not set	600-311-9711	Engine		Not registered at the beginning	
				600-319-3510	1	600-319-3400	1	(Consolidated in the part number on the left)	600-319-3310	1	Need not be modified (Same as the latest)	Engine	AT03089	Additional filter with clear ball (white)		
9	WA500-3	SA6D140E-3	CRI	600-319-3510	1	600-319-3400	1	(Consolidated in the part number on the left)	600-319-3310	1	Not set	600-311-9711	Engine		Not registered at the beginning	
				600-319-3510	1	600-319-3400	1	(Consolidated in the part number on the left)	600-319-3310	1	Need not be modified (Same as the latest)	Engine	AT03057	Additional filter with clear ball (white)		
10	HM350-1	SAA6D140E-3	CRI	600-319-3510	1	600-319-3400	1	(Consolidated in the part number on the left)	600-319-3310	1	Not set	600-311-9711	Machine body		Not registered at the beginning	
				600-319-3510	1	600-319-3400	1	(Consolidated in the part number on the left)	600-319-3310	1	Need not be modified (Same as the latest)	Machine body	Service News will be issued on June 2004	Additional filter with clear ball (white) already set		
11	HM400-1	SAA6D140E-3	CRI	600-319-3510	1	600-319-3400	1	(Consolidated in the part number on the left)	600-319-3310	1	Not set	600-311-9711	Machine body		Not registered at the beginning	
				600-319-3510	1	600-319-3400	1	(Consolidated in the part number on the left)	600-319-3310	1	Need not be modified (Same as the latest)	Machine body	Service News will be issued on June 2004	Additional filter with clear ball (white) already set		
12	HD325-6	SAA6D140E-3	CRI	600-319-3510	1	600-319-3310 ***	2	600-311-9711	600-311-3110	1	600-311-7111	2	600-311-9711	Machine body	BT02041	Specification with twin additional filters
				600-319-3510	1	600-319-3400	1	(Consolidated in the part number on the left)	600-319-3310	1	Need not be modified (Same as the latest)	Machine body	Service News will be issued on June 2004	Additional filter with clear ball (white) already set		
13	CS360-2E	SA6D140E-3	CRI	600-319-3510	1	Not registered			600-319-3310	1	Not set					
14	WZ4000-1	SAA6D140E-3	CRI	600-319-3510	1	Not registered			600-319-3310	1	Not set					
15	GS500-1	SAA6D140E-3	CRI	600-319-3510	1	Not registered			600-319-3310	1	Not set					
16	GC380F-2	SAA6D140E-3	CRI	600-319-3510	1	Not registered			600-319-3310	1	Not set					
170Eng (For tier 2)																
1	WA600-3E	SAA6D170E-3	HPI	600-319-3200	4	-		(Consolidated in the part number on the left)	600-319-3200	2	-		(Consolidated in the part number on the left)	Engine	Not set	
2	WA700-3E	SAA6D170E-3	HPI	600-319-3200	4	-		(Consolidated in the part number on the left)	600-319-3200	2	-		(Consolidated in the part number on the left)	Machine body	Not set	
3	HD465-7	SAA6D170E-3	HPI	600-319-3200	4	-		(Consolidated in the part number on the left)	600-319-3200	2	-		(Consolidated in the part number on the left)	Machine body	BT04013	Additional twin filters with clear balls (black)
4	PC1250-7	SAA6D170E-3	HPI	600-319-3200	4	-		(Consolidated in the part number on the left)	600-319-3200	2	-		(Consolidated in the part number on the left)	Machine body	BT03029	Additional twin filters with clear balls (black)
5	D375A-5	SA6D170E-3	HPI	600-319-3200	4	-		(Consolidated in the part number on the left)	600-319-3200	2	-		(Consolidated in the part number on the left)	Engine	BT0417	Additional twin filters with clear balls (black)

* For the 170 engine main filter, low grade fuel specification has 600-319-3200 x 4 and standard specification has 600-319-3111 x 2, and no pre-filter attached. (See page 3)

The 125/140 engine main filter is common to the standard and low grade fuel specifications that provide 600-319-3510 x 1. (See page 4)

** Pre-filter/main filter part No. configuration with water separator built-in (For details, see page 5.)

125/140 Pre-filter

600-319-3400: Ass'y Part No.

600-319-3440 Filter unit

600-311-3220 Clear ball (Water separator)

170 Main filter

600-319-3200: Ass'y Part No.

600-319-3240 Filter unit

600-311-3220 Clear ball (Water separator)

*** To cope with low grade fuel for the 140 engine, the PC600-6, PC750-6 and HD325-6 provide a twin additional fuel filter before 5AB12 is developed. (5AB10 + 5AB11) In some serial numbers, mount the 600-319-3310 two units. (See page 4.)

**** For service news on the fuel filter to be improved in association with the fuel filter cartridge to be improved at this time, see page 6.

. A cap is added to the refill filter cartridge. To replace the cap and filter, see pages 7 and 8.

. The old-version main filter 600-319-3310 for the 125 and 140 engines can be diverted as a twin extended filter or main filter for domestic power unit.

2) List of cartridge part numbers for fuel filter as spare parts including parts
(Standard specifications)

NO	Model	Engine	Fuel injection unit	Fuel filter (Latest)		Fuel filter (Old)	
				Cartridge part No.	Q'ty	Cartridge part No.	Q'ty

125Eng (For tier 2)

1	PC400-7	SAA6D125-3	CRI	600-319-3510	1	600-319-3310	1
2	WA470-5	SAA6D125-3	CRI	600-319-3510	1	600-319-3310	1
3	WA480-5	SAA6D125-3	CRI	600-319-3510	1	600-319-3310	1
4	D65-15	SA6D125E-3	CRI	600-319-3510	1	600-319-3310	1
5	D85-15	SA6D125E-3	CRI	600-319-3510	1	600-319-3310	1
6	HM300-1	SAA6D125-3	CRI	600-319-3510	1	600-319-3310	1
7	HD255-1	SAA6D125-3	CRI	600-319-3510	1	600-319-3310	1
8	GD755-3	SAA6D125-3	CRI	600-319-3510	1	600-319-3310	1
9	GH320-3	SAA6D125-3	CRI	600-319-3510	1	600-319-3310	1

140Eng (For tier 2)

1	PC600-6	SA6D140E-3	CRI	600-319-3510	1	600-311-3110	1
				600-319-3510	1	600-311-3110	1
				600-319-3510	1	600-319-3310	1
2	PC600-7	SA6D140E-3	CRI	600-319-3510	1	600-319-3310	1
3	PC750-6	SAA6D140E-3	CRI	600-319-3510	1	600-311-3110	1
				600-319-3510	1	600-311-3110	1
				600-319-3510	1	600-319-3310	1
4	PC750-7	SAA6D140E-3	CRI	600-319-3510	1	600-319-3310	1
5	PC1800-6	SAA6D140E-3	CRI	600-319-3510	1	600-319-3310	1
				600-319-3510	1	600-319-3310	1
6	D155AX-5A	SA6D140E-3	CRI	600-319-3510	1	600-319-3310	1
				600-319-3510	1	600-319-3310	1
7	D155AX-5B	SA6D140E-3	CRI	600-319-3510	1	600-319-3310	1
8	D275A(X)-5	SDA6D140E-3	CRI	600-319-3510	1	600-319-3310	1
				600-319-3510	1	600-319-3310	1
9	WA500-3	SA6D140E-3	CRI	600-319-3510	1	600-319-3310	1
				600-319-3510	1	600-319-3310	1
10	HM350-1	SA6D140E-3	CRI	600-319-3510	1	600-319-3310	1
				600-319-3510	1	600-319-3310	1
11	HM400-1	SA6D140E-3	CRI	600-319-3510	1	600-319-3310	1
				600-319-3510	1	600-319-3310	1
12	HD325-6	SAA6D140E-3	CRI	600-319-3510	1	600-311-3110	1
				600-319-3510	1	600-319-3310	1
13	CS360-2E	SA6D140E-3	CRI	600-319-3510	1	600-319-3310	1
14	WZ4000-1	SAA6D140E-3	CRI	600-319-3510	1	600-319-3310	1
15	GS300-1	SAA6D140E-3	CRI	600-319-3510	1	600-319-3310	1
16	GC380F-2	SAA6D140E-3	CRI	600-319-3510	1	600-319-3310	1

170Eng (For tier 2)

NO	Model	Engine	Fuel injection unit	Fuel filter (Latest)		Fuel filter (Old)	
				Cartridge part No.	Q'ty	Cartridge part No.	Q'ty
1	WA600-3E	SAA6D170E-3	HPI	600-319-3111	2	600-319-3111	2
2	WA700-3E	SAA6D170E-3	HPI	600-319-3111	2	600-319-3111	2
3	HD465-7	SAA6D170E-3	HPI	600-319-3111	2	600-319-3111	2
4	PC1250-7	SAA6D170E-3	HPI	600-319-3111	2	600-319-3111	2
5	D375A-5	SA6D170E-3	HPI	600-319-3111	2	600-319-3111	2

2) SA(A)6D170E-3 Standard specifications

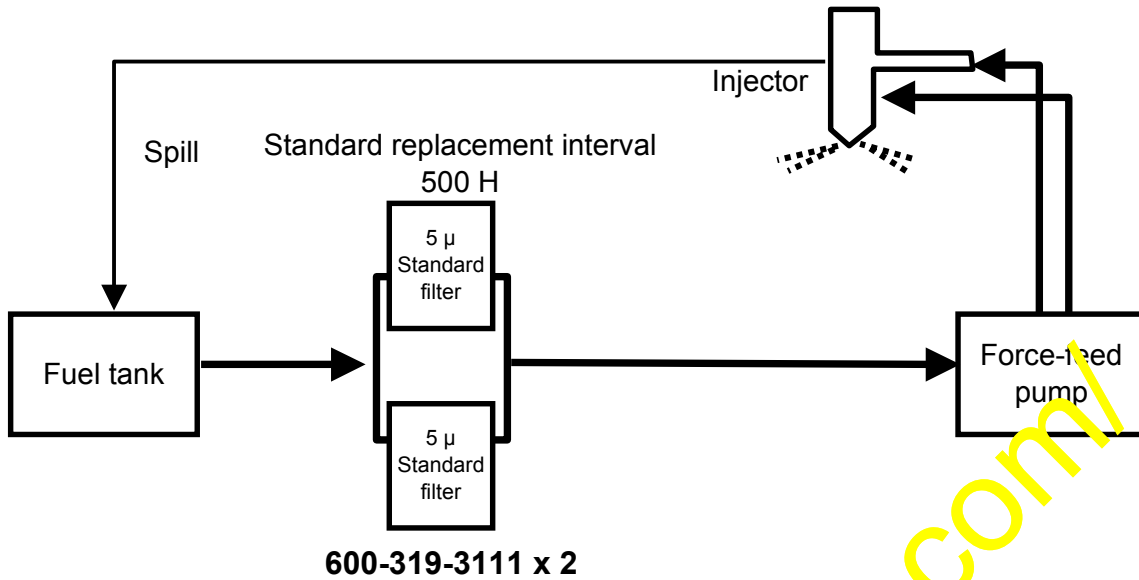

Fig. 1

3) SA(A)6D170E-3 Low grade fuel specifications (5AB14)

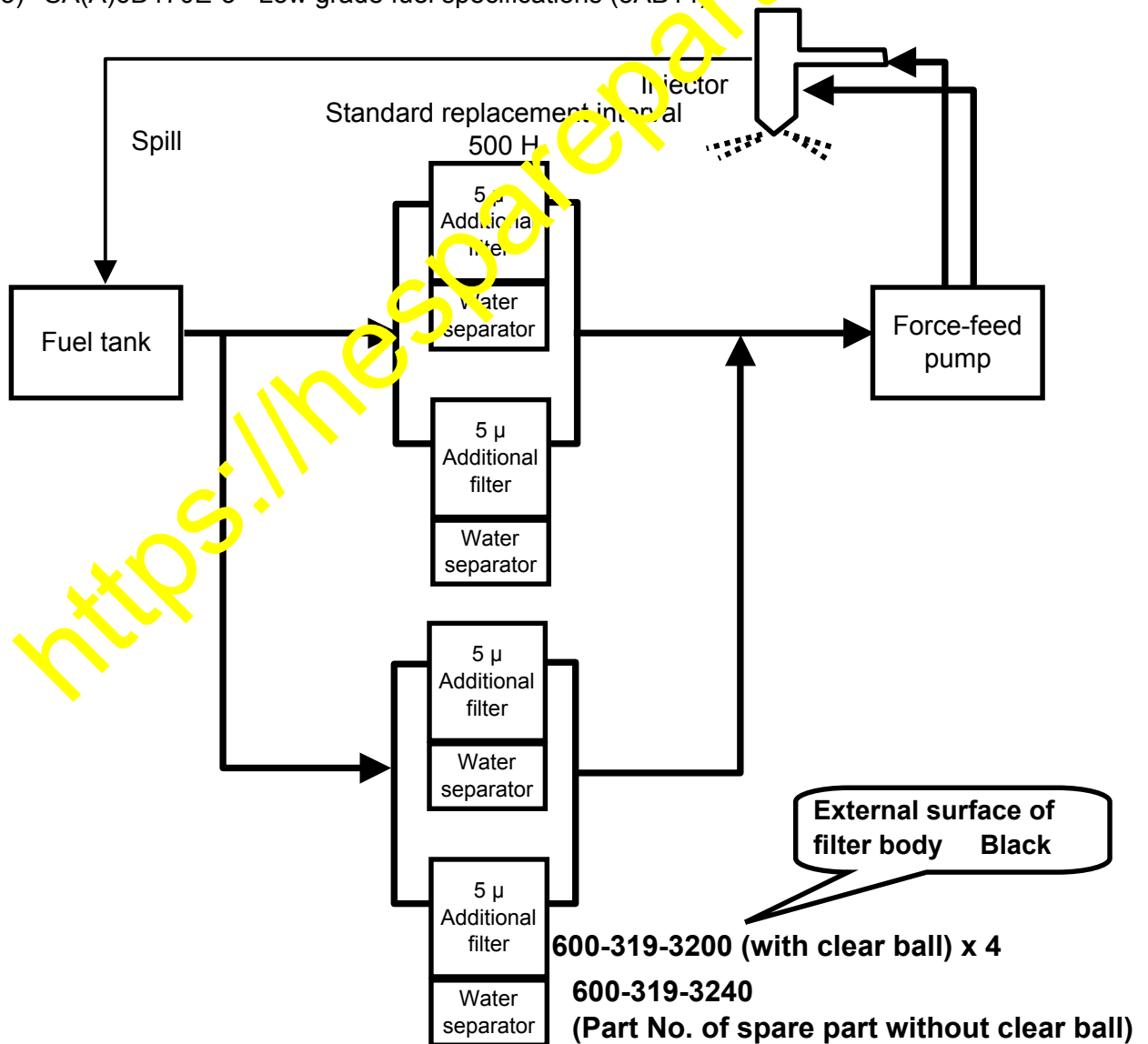

Fig. 2

- 4) SA(A)6D125E-3
SA(A)6D140E-3 Standard specifications

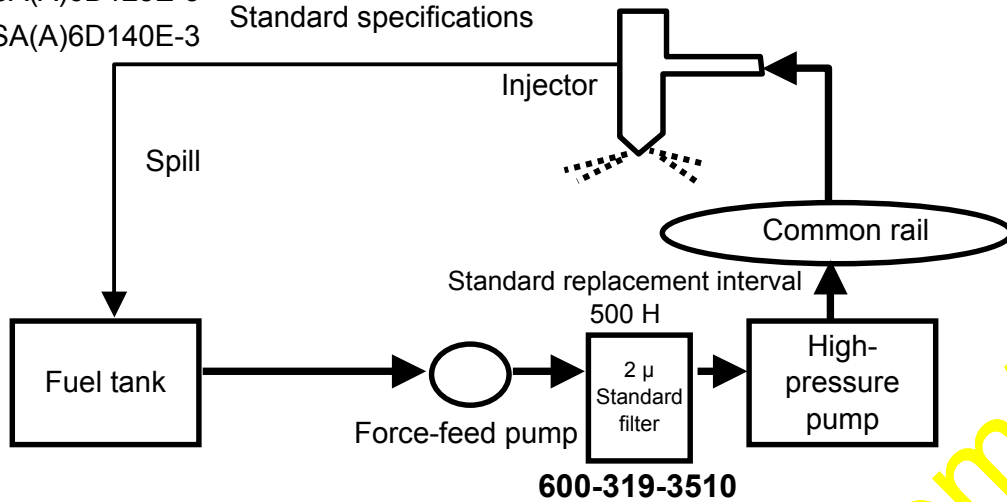
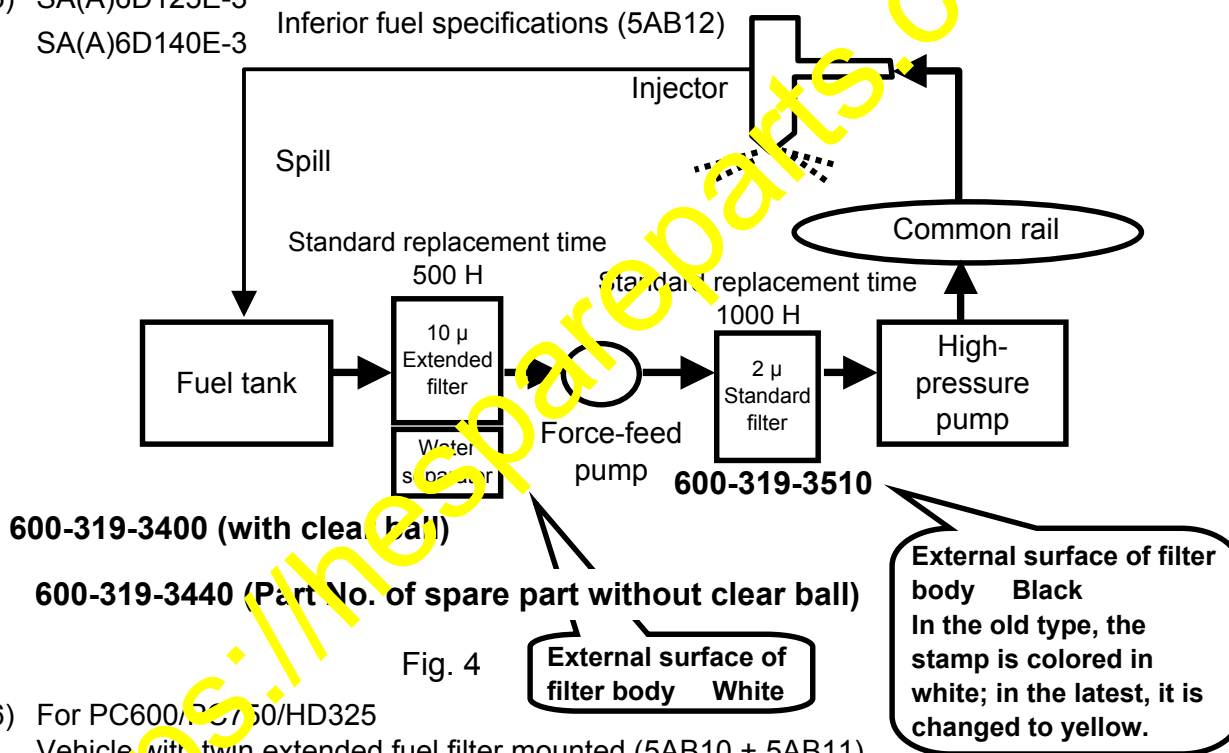
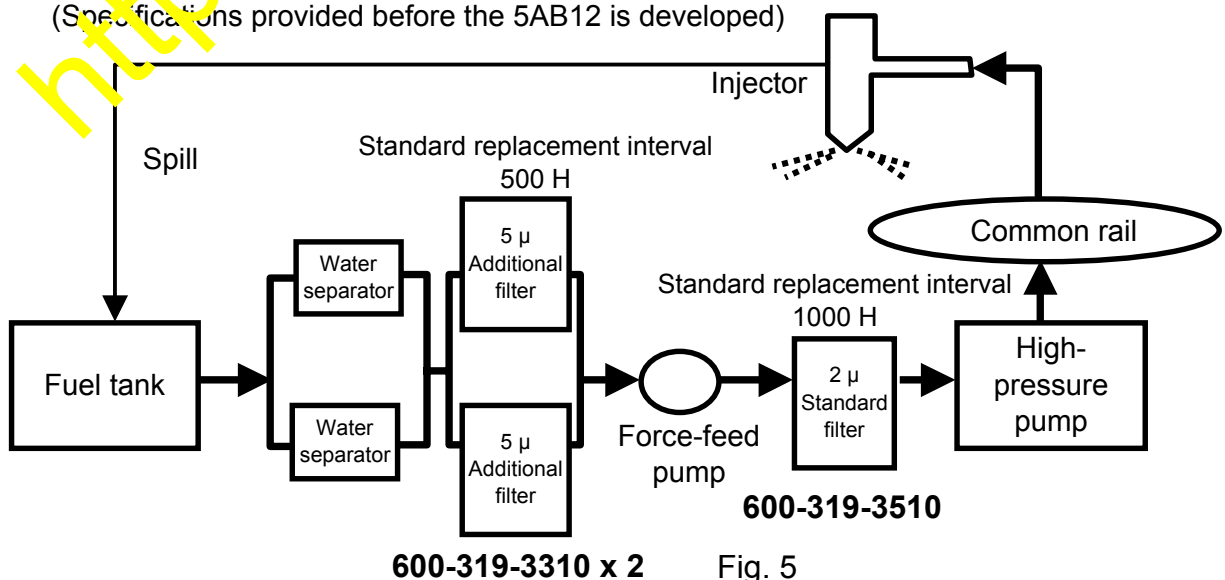

Fig. 3

- 5) SA(A)6D125E-3
SA(A)6D140E-3 Inferior fuel specifications (5AB12)



- 6) For PC600/227/50/HD325
Vehicle with twin extended fuel filter mounted (5AB10 + 5AB11)
(Specifications provided before the 5AB12 is developed)



- 7) Additional fuel filter for low grade fuel use areas
 - Φ125, 140CRI: 600-319-3440 (Spare parts, without clear ball)
 - Φ170HPI: 600-319-3240 (Spare parts, without clear ball)

Note: The part No. is different between the cartridge unit and its spare.
 (The part No. is stamped only on the cartridge unit.)

- Φ125,140CRI: 600-319-3440 (Spare part No.) =
 600-311-3410 (Cartridge unit part No.) + 600-311-3230 (Seal) + ① (Cap, sub part No.)
- Φ170HPI: 600-319-3240 (Spare part No.) =
 600-311-3210 (Cartridge unit part No.) + 600-311-3230 (Seal) + ① (Cap, sub part No.)

Information: The assembly part No. with clear ball has been registered.

(In the same way as above, this part No. is stamped only on the cartridge unit. Note that the part No. is different between the cartridge unit and assembly with clear ball.)

- Φ125,140CRI: **600-319-3400 (Assembly part No. with clear ball) =**
 600-311-3410 (Cartridge unit part No.) + 600-311-3230 (Seal) + ① (Cap, sub part No.) + **600-311-3220**
 (Clear ball part No.)
- Φ170HPI: **600-319-3200 (Assembly part No. with clear ball) =**
 600-311-3210 (Cartridge unit part No.) + 600-311-3230 (Seal) + ① (Cap, sub part No.) + **600-311-3220**
 (Clear ball part No.)

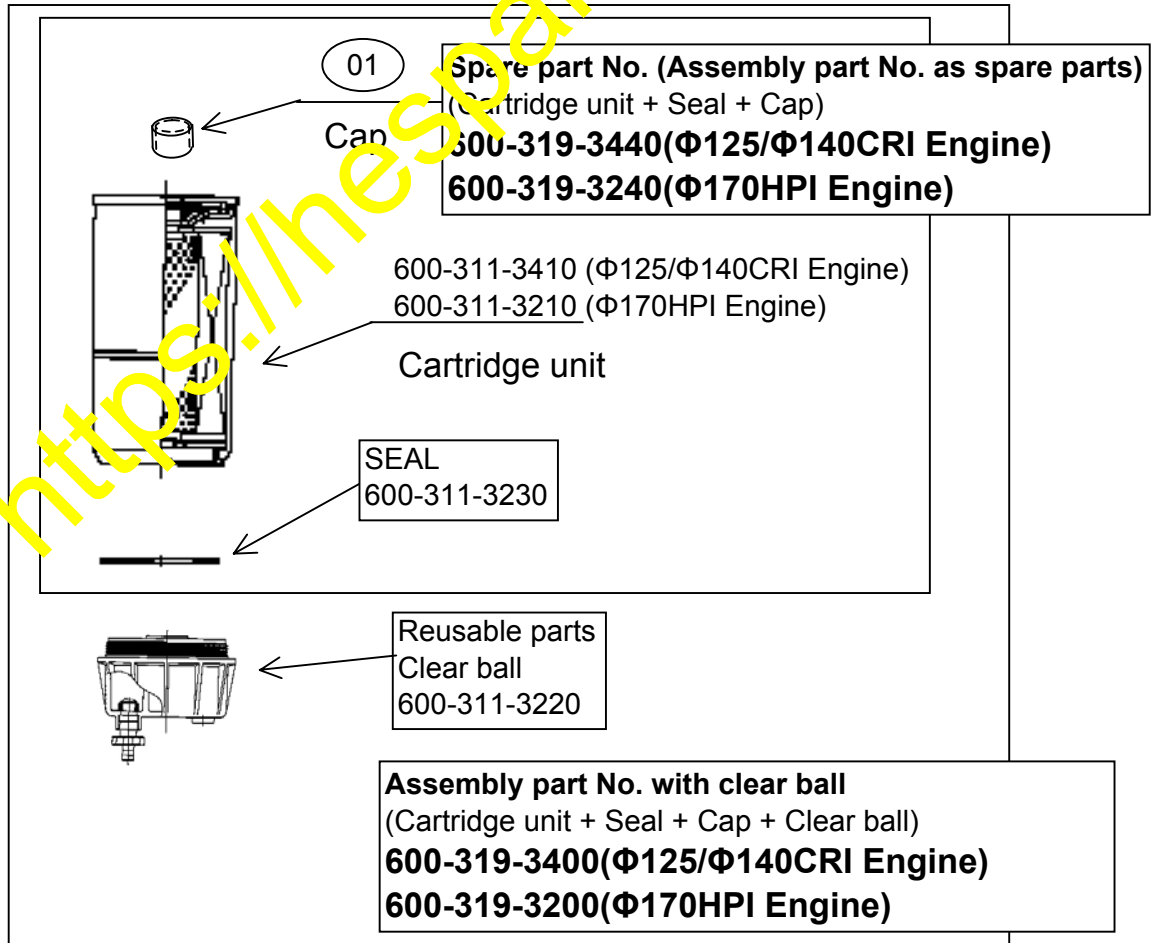

Fig. 6

- 8) Standard fuel filter Φ 125,140CRI: 600-319-3510
 Φ 170HPI: 600-319-3111

Note: The part No. is different between the cartridge unit and its spare.
 (The part No. is stamped only on the cartridge unit.)

600-319-3510 (Spare part No.) = 600-311-3510 (Cartridge unit part No.) + 01 (Detailed cap part No.)
 600-319-3111 (Spare part No.) = 600-311-3111 (Cartridge unit part No.) + 01 (Detailed cap part No.)

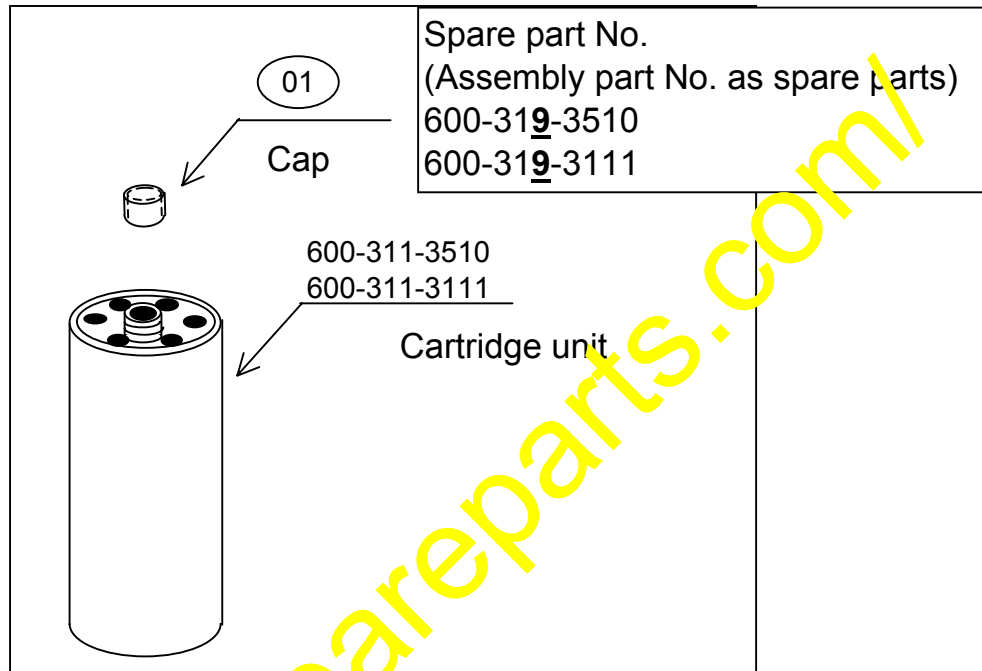

Fig. 7

- 9) The table of the related revised edition of Service News.

No.	Service news	Subject
1	Cancelled: AT01199	Engine high-performance fuel filter
2	Cancelled: AT02105	Introduction of low-price fuel filter for common rail engine
3	Revised: AT02106	Introduction of fuel filter water separator for Tier 2 engine
4	Revised: AT03059	Addition of fuel filter cap and improvement of fuel filter
5	Revised: AT03093	Introduction of investigating a common rail non-force-feed error
6	Revised: AT03094	Fuel used for engine with common rail and its countermeasures

10) Fuel filter cartridge replacement procedure (Fuel charging method)

When replacing the fuel filter cartridge, follow the procedure below to charge the filter with fuel.

<1> Before charging the filter with fuel, check that the cap (A) is attached.

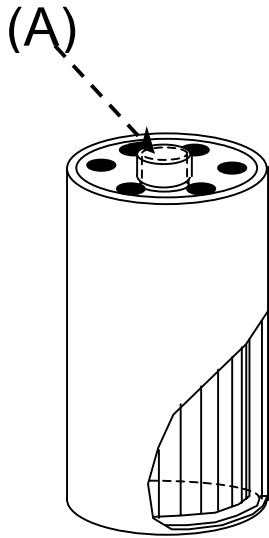

Fig. 8

<2> Charge the filter with the cap (A) attached with fuel.

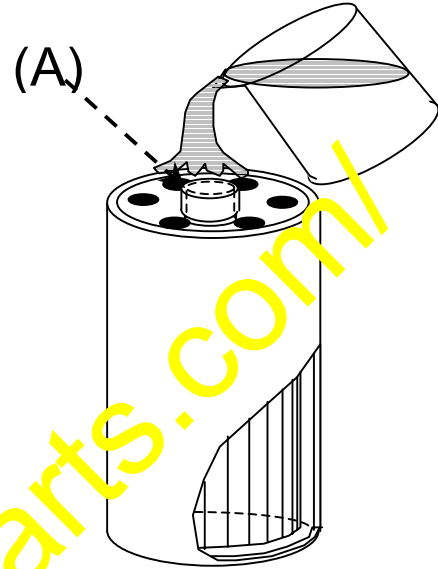

Fig. 9

<3> After filling up the filter with fuel, remove the cap (A) and dispose of it.

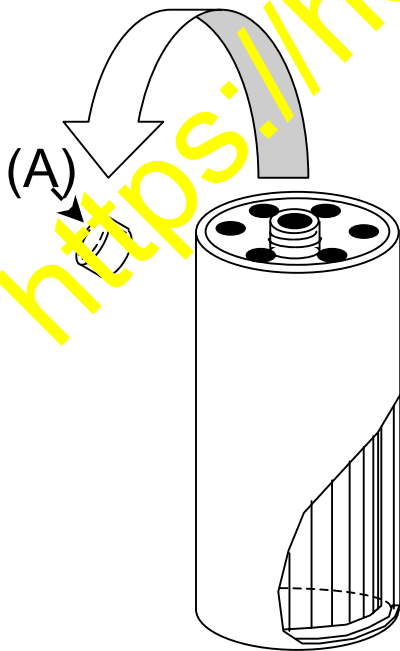

Fig. 10

<4> After thinly applying the engine oil on the packing surface of the fuel filter, attach it to the filter head and check that the packing surface comes into contact with the seal surface of the filter head. Then fasten it 3/4 turns.

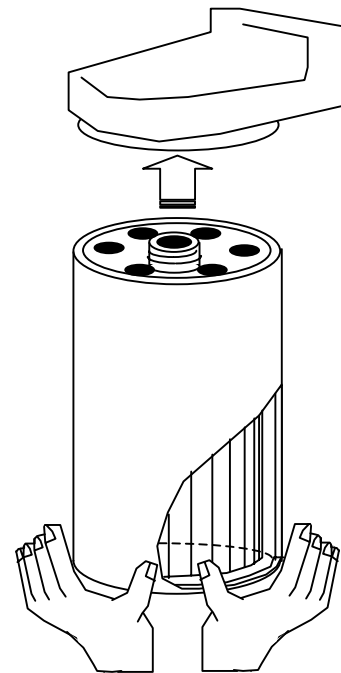

Fig. 11

11) Fuel filter cap

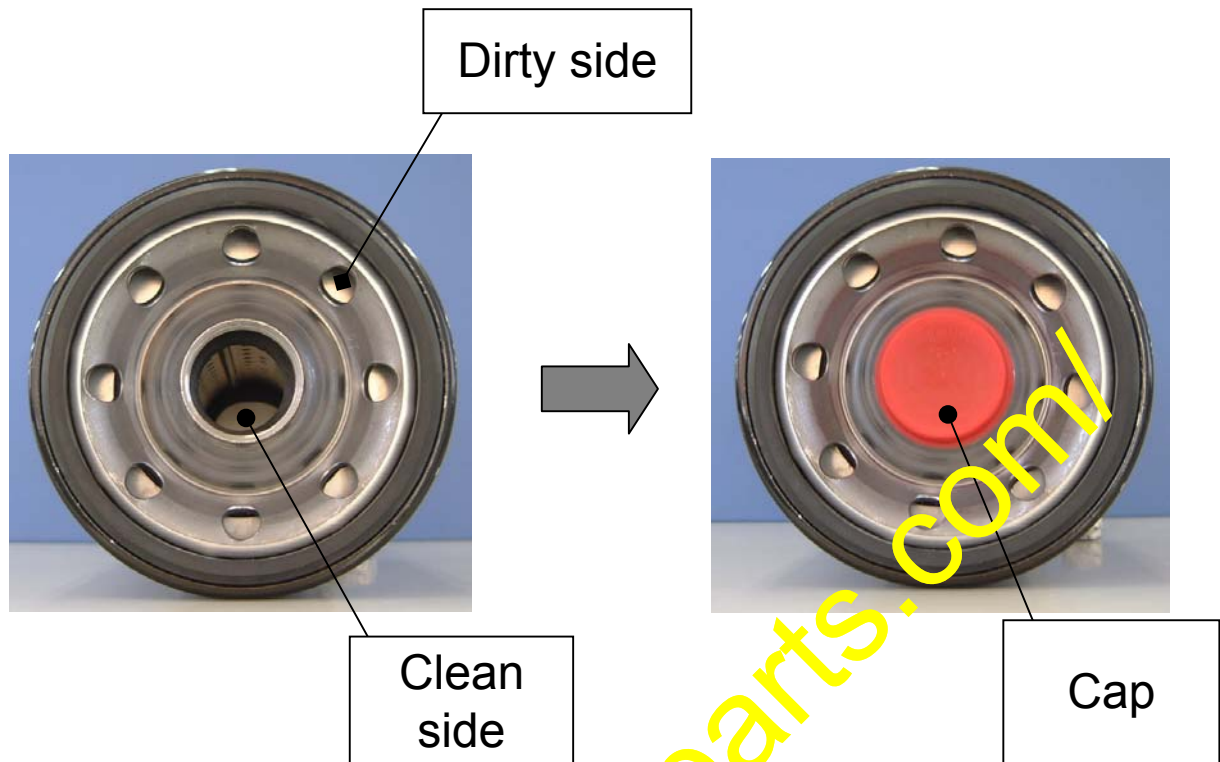

Fig 12

12) Reason for installing a cap

To prevent dust from entering the clean side

The operation and maintenance manual explains that only the dirty side of the filter must be filled up with fuel when replacing the fuel filter.

In the actual structure, however, there may be cases when the operator also pour fuel into the clean side through carelessness. (If fuel dust is got in the clean side of the filter, it may result in a failure of the fuel injection system.)

To avoid the case, the cap for covering the clean side is attached additionally.

On the next page, it is shown how to replace a filter with this cap (a cap is attached to the spare part).