

INSTALLATION MANUAL

REF NO.	BA04021
DATE	December 23, 2004

- SUBJECT:** INSTALLATION OF STEERING OIL COOLER BY-PASS DEVICE
- PURPOSE:** To introduce a procedure to install a device that will by-pass the steering oil cooler when the hydraulic oil is cold, so a more consistent warm up is possible during lower ambient temperatures.
- APPLICATION:** WA250-3MC Wheel Loader Serial Number A71001 and UP
WA250PT-3MC Wheel Loader Serial Number A78001 and UP
- FAILURE CODE:** 03C0NG
- DESCRIPTION:** To aid in warming up the steering oil during cold start situations in cold working conditions.

MACHINE PREPARATION

1. Park the machine on a flat level surface; lower the work equipment to the ground. Shut off the engine and cycle the controls to remove any residual hydraulic pressure from the work equipment circuits. Turn the parking brake switch on and block the tires or tracks.
2. Remove the key from the ignition switch until the repairs are complete. Place a tag on the steering controls advising: "This machine is being repaired. It should not be started or moved for any reason until the tag is removed by the person doing the repairs."



WARNING! Observe all safety and precautionary standards as dictated by the environment and work conditions under which the equipment will be inspected, reworked and repaired. Consult the "Shop Manual" and "Operator's and Maintenance Manual" and your Komatsu district service manager with any/all questions regarding safety.

Remark

These instructions are intended to supplement the service data contained in the appropriate "Shop Manual". Always refer to that manual for Removal, Installation, Disassembly and Reassembly instructions when not contained in this document.

PART LISTING

No.	Part Number	Description	Qty.	Remark
1	418-62-A1930	STEERING VALVE	1	
2	418-62-A1040	BRACKET.	1	
3	418-62-A1050	TEE (LH)	1	
4	418-62-A1060	TEE (RH)	1	
5	418-62-A1940	HOSE (LH).	1	
6	418-62-A1950	HOSE (RH).	1	
7	418-62-A1960	ELBOW.	1	
8	418-62-A1970	UNION.	1	
9	07002-12434	O-RING	2	
10	01435-01020	BOLT	2	
11	25678R1	BOLT	2	
12	25543R1	WASHER	2	
13	9413977	NUT.	2	
14	02896-11018	O-RING	2	

★ Parts Illustration

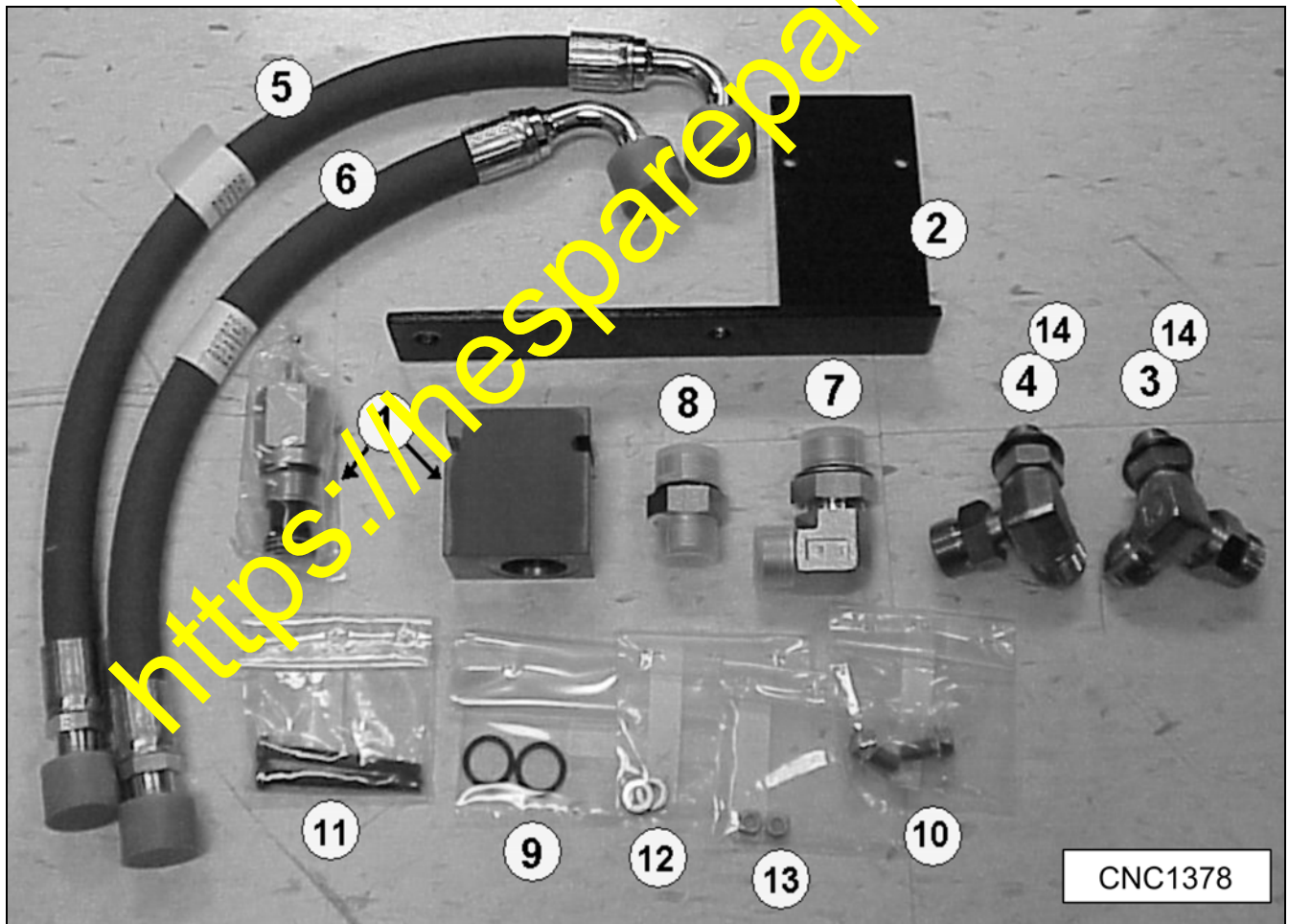

INSTALLATION PROCEDURES

1. Allow the machine to cool down to room temperatures.
2. After machine has cooled down, relieve hydraulic pressure in the steering system.
3. Install steering valve (1) to bracket (2) and install on the machine as shown in the illustration below.
4. Assemble hose (5) and tee (3) then install as shown in illustration below.
5. Assemble hose (6) and tee (4) then install as shown in illustration below.
6. Once bypass system is assembled and installed in place remove cooler inlet and outlet lines and loosely attach to bypass hoses.
7. Once attached to the bypass system, attach assembled tees (3) and (4) to the cooler.
8. Adjust hoses and tighten lines.

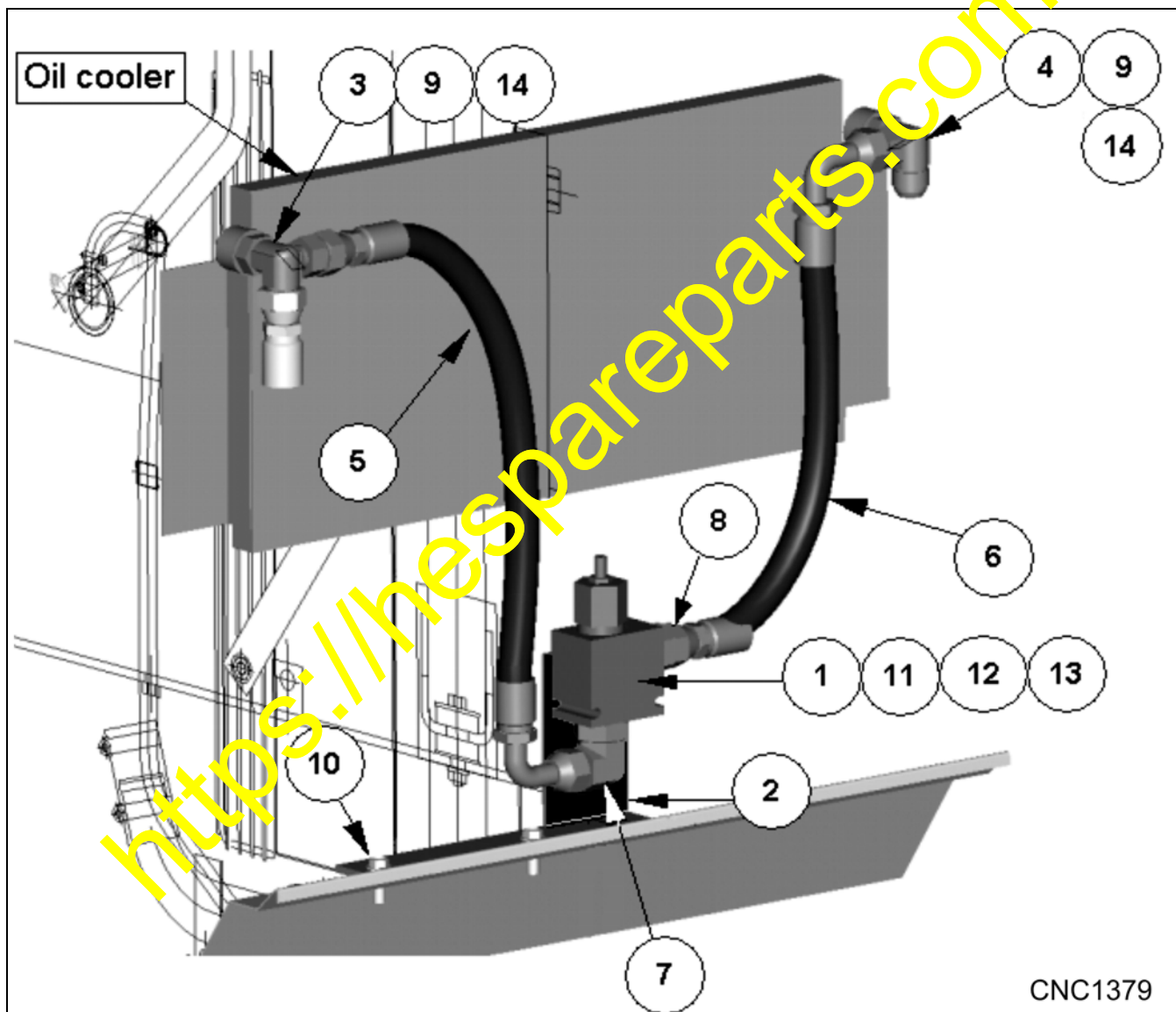

- ★ Start engine and operate system checking for leaks.