

PARTS & SERVICE NEWS

REF NO.	BT02010
DATE	Mar. 11, 2002

Page 1 of 4

SUBJECT: INSTALLATION PROCEDURE OF PRE-CLEANER ON WA380-5

PURPOSE: To introduce local installation procedure for the pre-cleaner onto WA380-5 wheel loaders

APPLICATION: WA380-5 Wheel loaders, Serial Nos. 60001 and up
 (Unit for individual sale X250474830)
 (6WL48-F(T))

FAILURE CODE: 0210Z9

DESCRIPTION:

1. Introduction

This Service News will introduce local installation procedure for the pre-cleaner which has been newly developed as an optional part for installation onto the WA380-5 wheel loaders.

This optional pre-cleaner is effective to extend the time before the air cleaner is clogged in case the machine is being used in dusty quarries or in work sites in sandy areas, etc.

Sales Unit Code: 6WL48-F(T)

2. List of parts

No.	Part No.	Part Name	Q'ty	Remarks
1	423-U12-3100	Pre-cleaner A.	1	
2	423-U12-3110	Bracket	1	
3	01010-81230	Bolt	4	
4	12454-26540	Washer	4	
5	600-181-0670	Hose,air	1	
6	07289-00170	Clamp	2	
7	198-06-14260	Hose	1	

3. Removing the parts which need to be removed for this installation work

Remove the following parts.

No.	Part No.	Part name	Q'ty
1	421-54-31381	Plate	1
2	01010-81225	Bolt	4
3	01643-31232	Washer	4

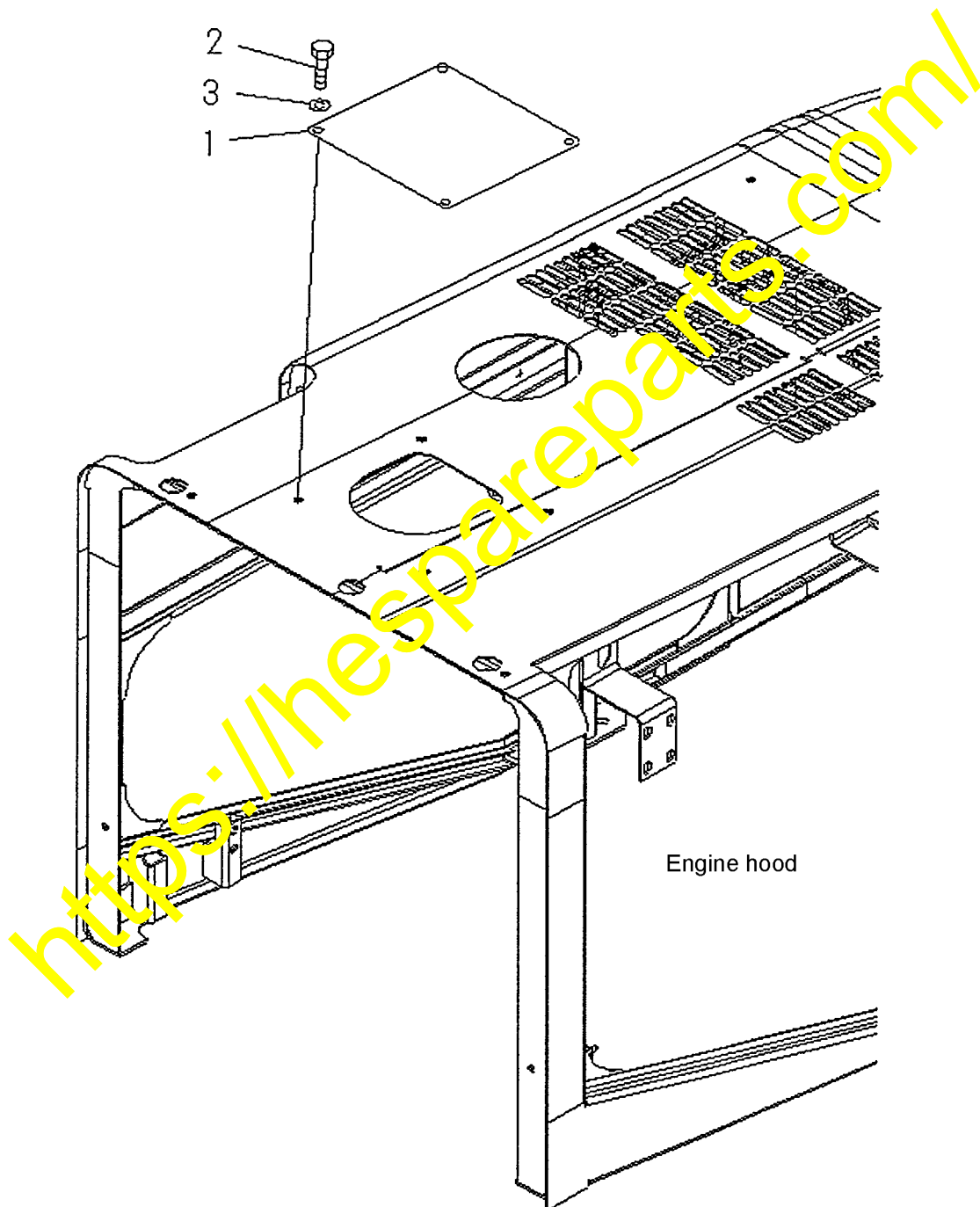

4. Replacing the parts
Replace the following parts.

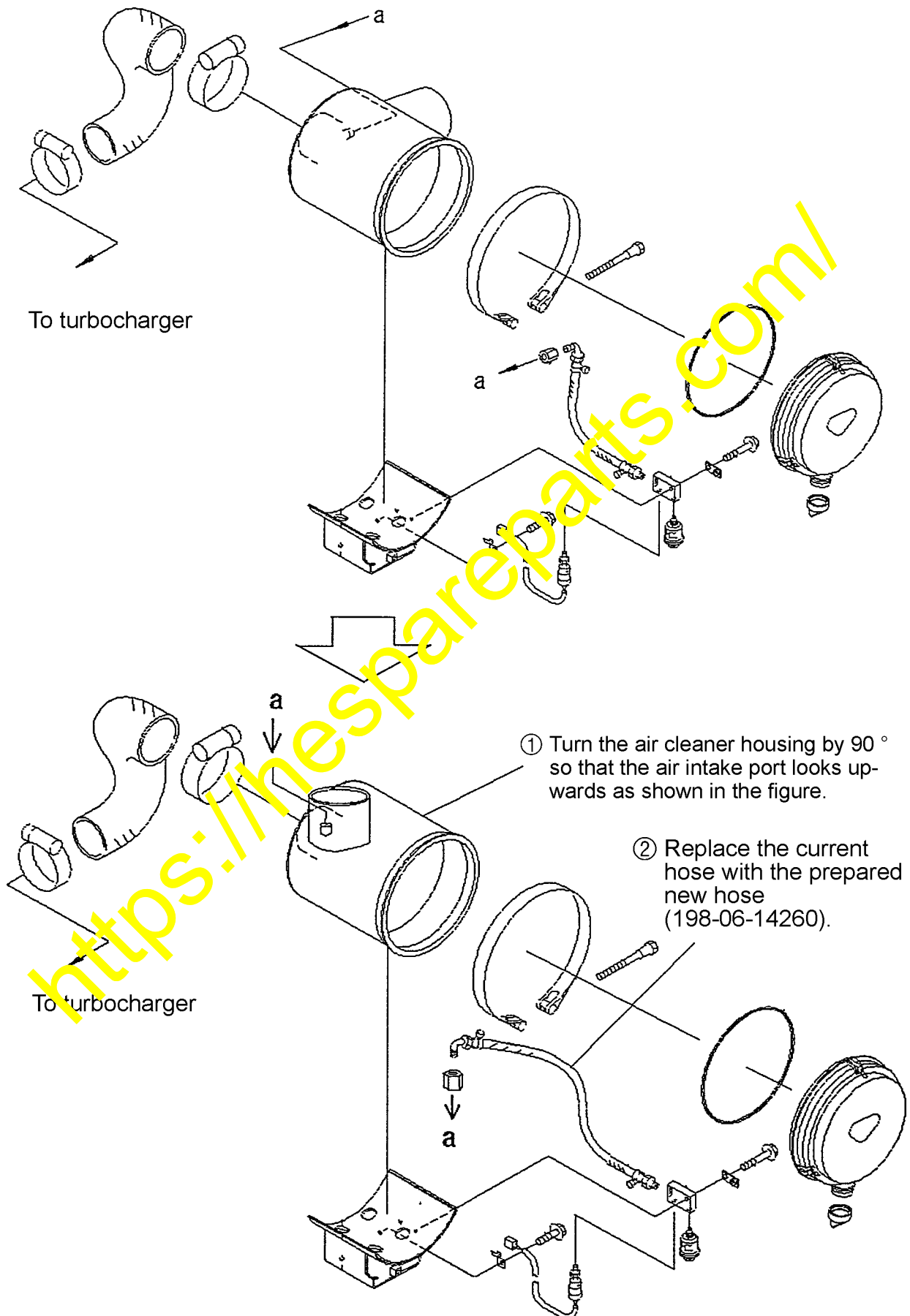

5. Installation procedure

Install the prepared parts as per the instructions given in the drawing below.

