

PARTS & SERVICE NEWS

REF NO.	BT99039
DATE	Oct. 20, 1999

Page 1 of 3

SUBJECT: INTRODUCTION OF RADIATOR CAP WITH MECHANICAL STOPPER OF HD785, HD985-3/-5

PURPOSE: To introduce the radiator cap with mechanical stopper function.

APPLICATION: HD785-3 Dump trucks, Serial Nos. 2001 thru 2574
 HD785-5 Dump trucks, Serial Nos. 4001 and up
 HD985-3 Dump trucks, Serial Nos. 1001 thru 1020
 HD985-5 Dump trucks, Serial Nos. 1021 and up

FAILURE CODE: 032599

DESCRIPTION:

1. Introduction

A radiator cap (conforming to SAE J164) provided with the function to serve as a mechanical stopper against the force applied in opening direction has been prepared for use on the HD785/985-3/-5 dump trucks.

(In order to install this radiator cap on the machine, either the radiator or radiator upper tank must be changed.)

2. List of parts

Part No.	Part Name	Q'ty	Remarks
561-03-61512 (561-03-61511)	Cap (Cap)	1 (1)	
561-03-61113 (561-03-61112)	Upper tank (Upper tank)	1 (1)	
561-03-61141	Gasket	1	Consumable part
561-03-64103 (531-03-64102)	Radiator Ass'y (Radiator Ass'y)	1 (1)	For case of ass'y replacement

3. Contents of the change

- 1) The shape of the latching sections of the cap and the filler port neck has been changed.

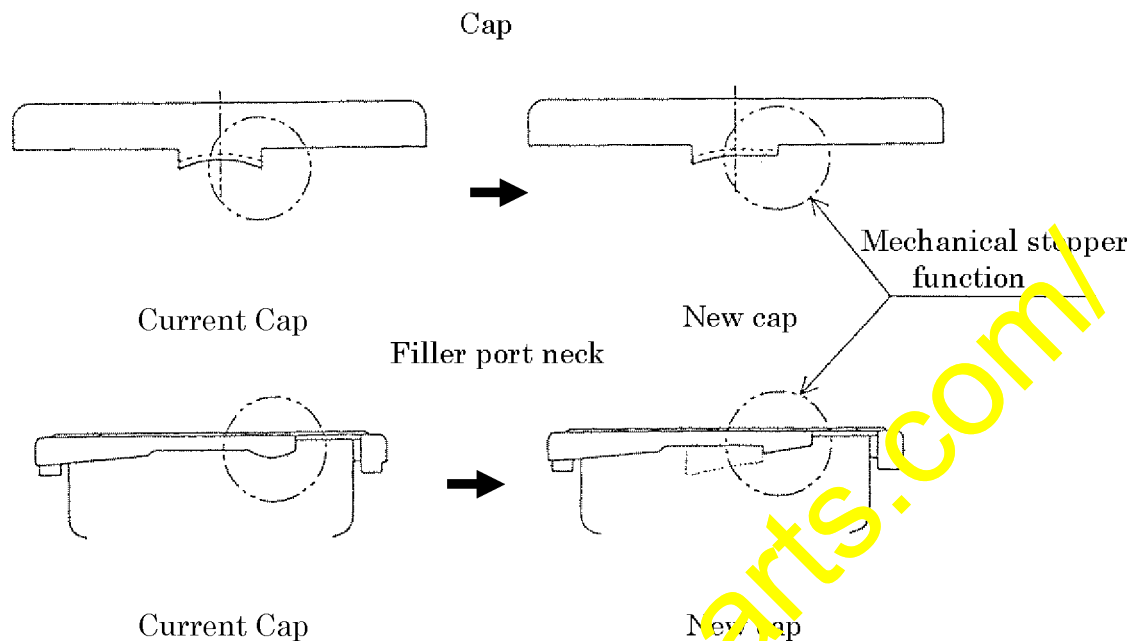

Fig-1 Contents of the change

4. Installation procedures

- 4.1 When replacing the radiator assy
Remove the water piping, hydraulic piping, oil-cooler, cooling water level sensor, etc. installed on the radiator temporarily before replacing the radiator with the one newly procured, then reinstall the removed components.
(Refer to the Shop Manual for details.)

- 4.2 When replacing the upper tank
Remove the water piping, cooling water level sensor, etc. installed to the upper tank temporarily before replacing the upper tank and the cap with those newly procured, then reinstall the removed components.
At this time, replace the gasket with new one and apply sealant to both sides of the gasket.

5. Inspection

After assembling, check that there is no water leakage in the neighborhood.

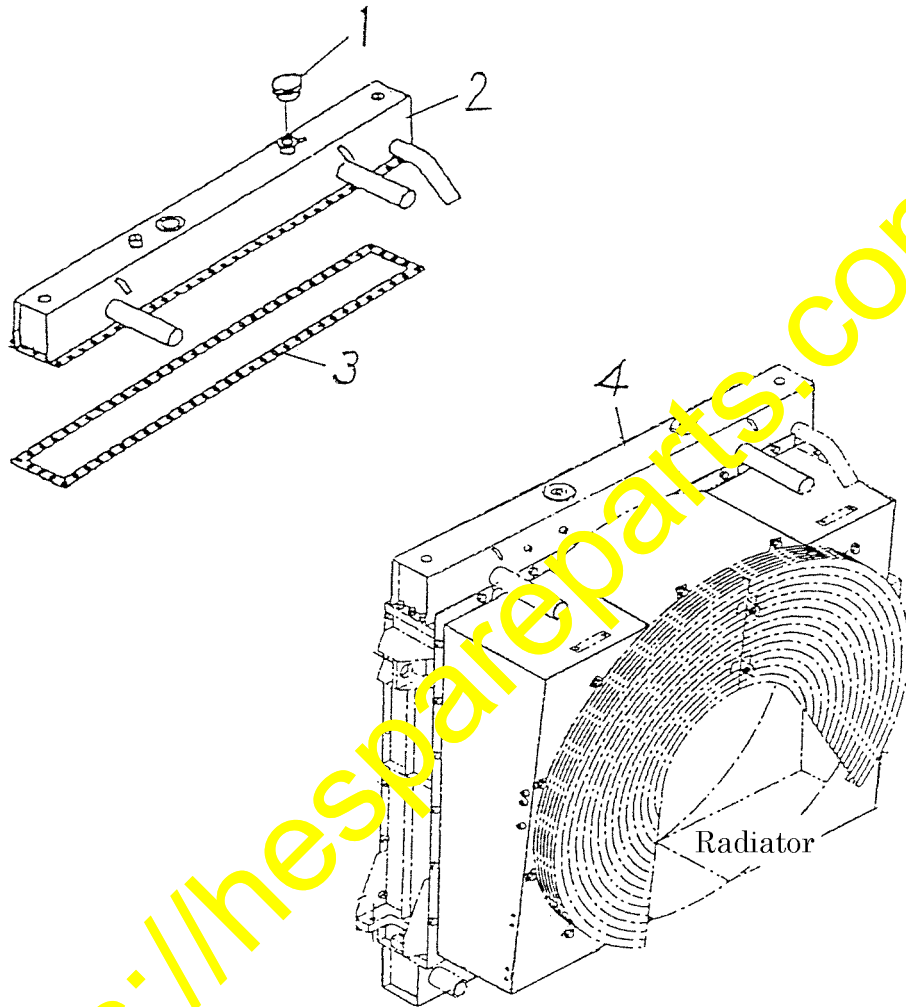

Fig-2 New parts