

***KAC Service***  
***Flash News***

**KOMATSU**

KOMATSU AMERICA CORPORATION

---

Issue Date: August 25, 2004

NEWS NUMBER: **FN04036**

To : All Komatsu Distributors

Component Group: **Swing Machinery**

SUBJECT: **PC3000-1 S/N 6193 Parts Book Update**

PURPOSE: To provide updated parts book information for the Slew Box installed on this unit. This breakdown will cover slew box part number **926-795-40**, installed July 31, 2004. Please see the following pages for this detail.

<https://hespareparts.com/>

**KOMATSU**

We reserve the right to make changes in specifications, construction or design at any time without incurring obligation to make such changes on products sold previously

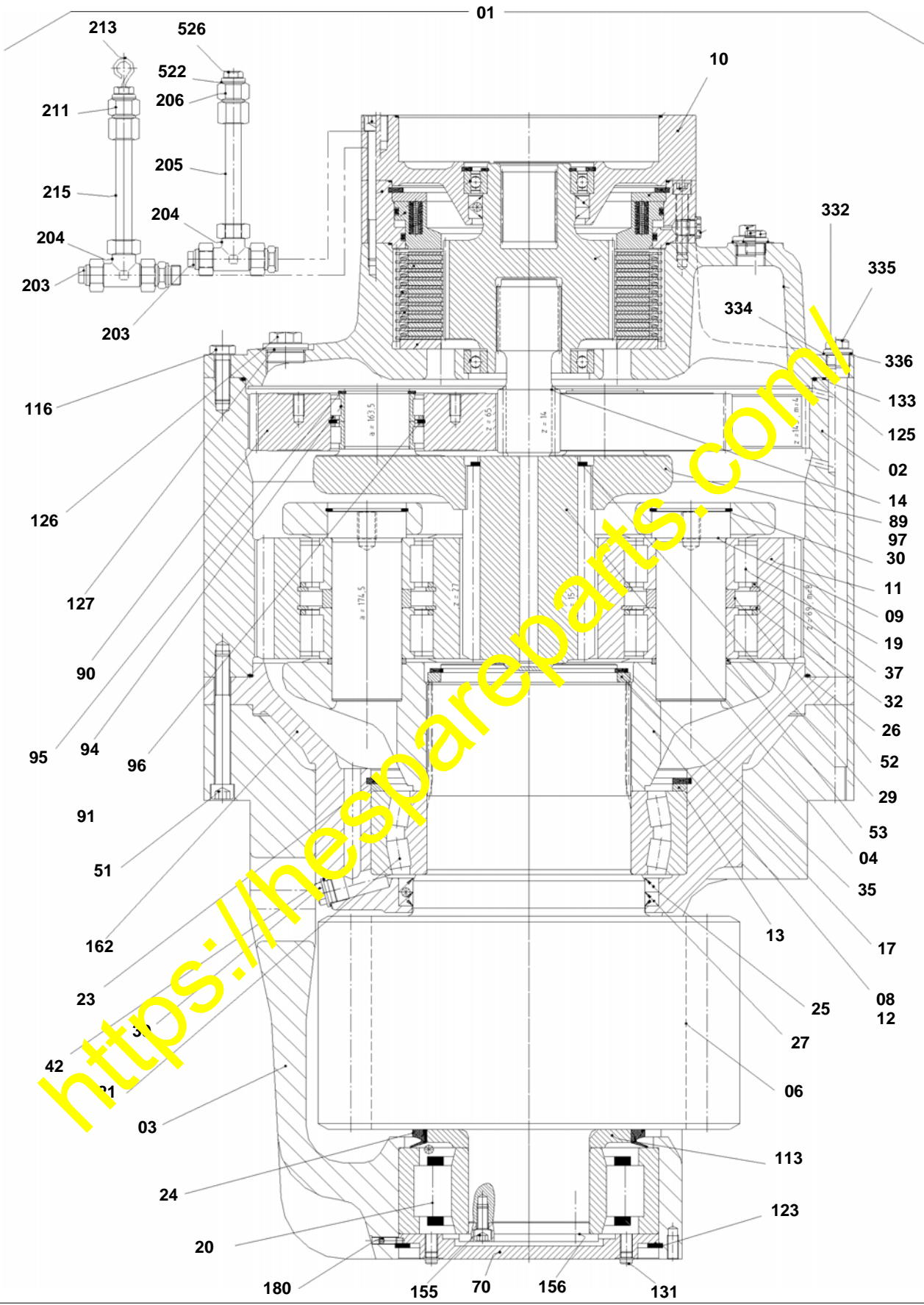

Slew Gearbox with Brake

991-0467  
Page 1

PC 3000-1 SN:06 199

11.09.2003

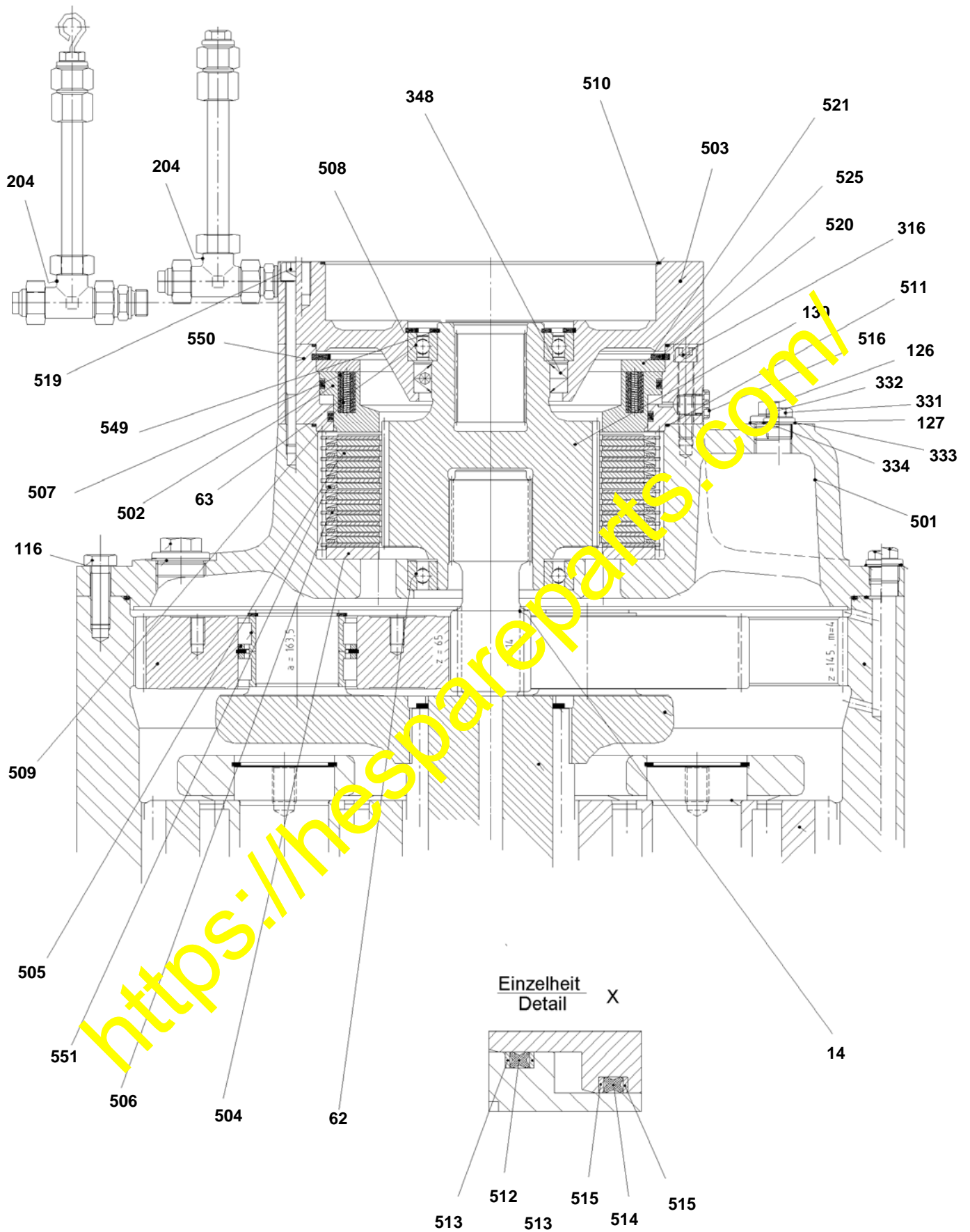

**Slew Gearbox with Brake**

**991-0467**  
Page 2

PC 3000-1 SN:06 199

11.09.2003



Bild-Nr Fig	ET-Nr Part-No	Menge Qty	Gegenstand Description
01	926 795 40	1	Slew gearbox assy.
02	792 234 73	1	Ring gear
03	792 235 73	1	Cartridge
04	792 236 73	1	Sunn gear z=15
06	792 237 73	1	Output shaft GFB 174
08	792 238 73	1	Planet carrier GFB 174
09	757 238 73	4	Planet bolt GFA 174
10	792 270 73	1	Brake assy
11	792 239 73	4	Planet gear z=27
12	792 269 73	1	Planetary Carrier assy consists of fig. no. 08,09,11, 19,30,32,37,32,53
13	763 730 73	1	Disk
14	757 360 73	1	Sun gear shaft
17	768 454 73	1	Disk
19	507 751 98	8	Cylindrical roller bearing
20	792 260 73	1	Cylindrical roller bearing
21	513 531 98	1	Spherical roller bearing
23	501 933 98	1	Circlip
24	757 252 73	1	Clamp collar
25	504 544 98	1	Radial shaft seal ring
26	507 748 98	1	O-ring
27	517 015 98	1	Radial shaft seal ring
29	342 572 99	1	Circlip
30	342 616 99	4	Circlip
32	342 619 99	8	Circlip
35	342 97 99	1	Circlip
37	502 242 40	6	Locating ring
39	349 989 99	1	Screw plug
42	340 084 99	1	Seal ring
51	513 136 98	4	Socket head cap screw
52	757 240 73	3	Spacer ring
53	763 731 73	3	Spacer ring
62	513 532 98	1	Ball bearing

Slew Gearbox with Brake

991-0467

Page 3

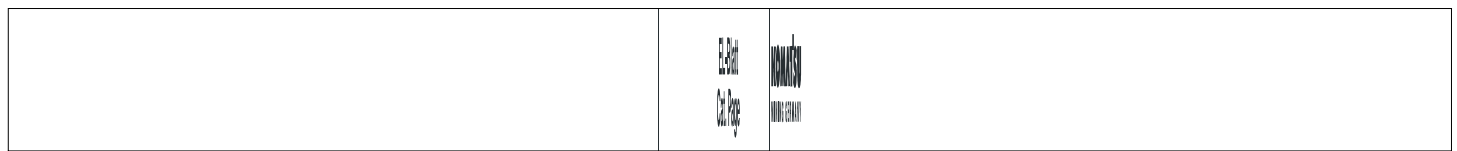

Bild-Nr Fig	ET-Nr Part-No	Menge Qty	Gegenstand Description
63	517 016 98	1	Ball bearing
70	792 233 73	1	Cover
89	792 240 73	1	Planet carrier GFB 174
90	767 764 73	3	Planet gear GFB 174
91	506 448 98	6	Cylindrical roller bearing
94	806 076 73	6	Locating ring
95	342 560 99	3	Circlip
96	342 670 99	3	Circlip
97	792 268 73	1	Planetary carrier assy consists of fig. no.08,89,90,91 94,95,96
113	792 241 73	1	Disk
116	509 834 98	8	Socket head cap screw
123	342 707 99	1	Circlip
125	507 748 98	1	O-ring
126	313 178 99	6	Screw plug
127	339 950 99	6	Seal ring
130	792 242 73	1	Drive Shaft
131	768 464 73	2	Plug
133	912 094	2	O-ring
155	319 155 98	6	Socket head cap srew
156	792 243 73	1	Cover
162	763 737 73	1	Bearing ring
180	517 514 98	1	Thread pin
203	371 816 99	2	Union
204	763 811 73	2	Union
205	215 812 99	AR	Precision tubing 18x1,5, lg 0,1 m
206	372 824 99	1	Union
211	372 834 99	1	Union
213	792 244 73	1	Dipstick G1/2" x156
215	215 812 99	AR	Precision tubing 18x1,5, lg 0,1 m Bulk ware, state length required
316	319 349 99	2	Socket head cap srew

Slew Gearbox with Brake

991-0467

Page 4

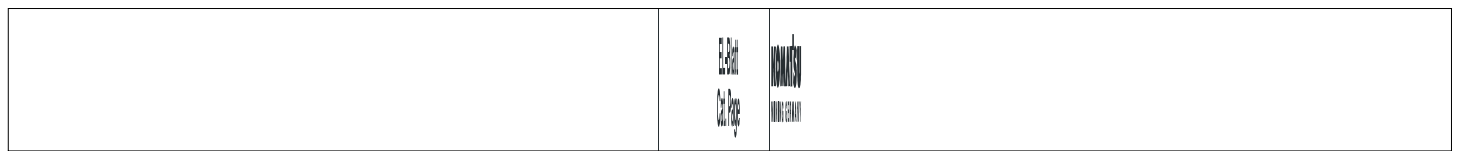

Bild-Nr Fig	ET-Nr Part-No	Menge Qty	Gegenstand Description
331	313 314 99	1	Plug
332	331 322 99	3	Plug
333	340 294 99	1	Seal ring
334	339 998 99	2	Seal ring
335	313 367 99	4	Plug
336	339 932 99	4	Seal ring
348	376 666 99	2	Radial shaft seal ring
501	792 246 73	1	Disk housing
502	792 247 73	1	Piston
503	792 248 73	1	Bearing ring
504	792 249 73	1	Disk
505	792 250 73	10	Inner disk
506	792 251 73	11	Outer disk
507	963 624	16	Pressure spring
508	342 678 99	1	Snap ring
509	806 036 73	14	Pressure spring
510	972 122	1	O-ring
511	972 122	1	O-ring
512	792 252 73	1	Piston seal
513	792 253 73	2	Support ring
514	792 254 73	1	Piston seal
515	792 256 73	2	Support ring
516	792 255 73	1	Plug
519	513 135 98	8	Socket head cap srew
520	342 708 99	1	Snap ring
521	792 257 73	1	Locating ring
522	342 256 99	1	Seal ring
525	972 122	1	O-ring
526	313 314 99	1	Plug
549	342 568 99	1	Snap ring
550	792 258 73	1	Seal ring
551	792 259 73	10	Seal ring

Slew Gearbox with Brake

991-0467

Page 5



--	--	--	--

Bild-Nr Fig	ET-Nr Part-No	Menge Qty	Gegenstand Description
	792 273 73	1	Seal Kit Slew Gearbox consists of fig. no. 25, 26, 27,125, 348, 510
	792 271 73	1	Repair Kit Brake consists of fig. nos. 505, 506, 507, 509, 512, 513, 514, 515

<https://hespareparts.com/>

**Slew Gearbox with Brake**

**991-0467**  
Page 6